

Würth Elektronik ICS GmbH & Co. KG

Intelligent Power & Control Systems

Gewerbepark Waldzimmern · Würthstraße 1 · 74676 Niedernhall · Germany

Phone: +49 7940 9810-0 · Fax: +49 7940 9810-1099

ics@we-online.com · www.we-online.com/ics



Central Electrical Unit

Power Logic Module

Ref : ICS-95897

REDLINE

Features

- 12 V or 24 V system available (Ref.: ICS-95897_12V or ICS-95897_24V)
- 2 power relay bases
- 9-way relay base for Micro ICCS or ICCS Micro CAN, which controls and commands two power relays
- Fly wheel diode (SM4007) in parallel of relay coil
- Green LED indicator (modes to be programmed in Micro ICCS)
- 1 MAXI fuse holder
- 4 Powerelements for input/output
 - 2 Powerelements per circuit
 - Circuit 1 is composed of 1 power relay protected by MAXI fuse and 2 Powerelements
 - Circuit 2 is composed of 1 power relay, 2 Powerelements and is not protected
- Cable harness connection on the rear side of the module via JPT/MCP compatible: 3-row, 6-way connector

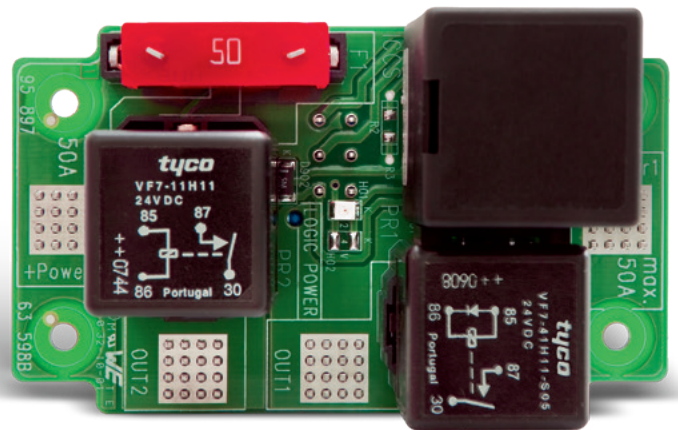

Front View

Options

- Installation of power relays and / or MAXI fuse according to customer requirements
- Installation of Micro ICCS for special function, with or without CAN (high speed)
- Installation of SMD or THT pads for CAN bus termination

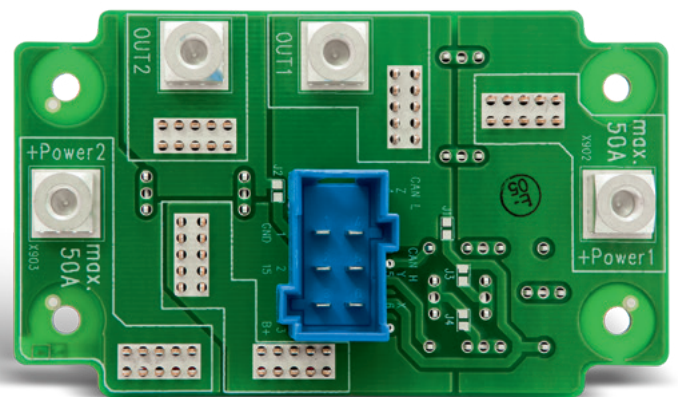

Rear View

Applications

By using Micro ICCS, any logical functions requesting up to 4 digital inputs, or 3 digital inputs and 1 analogue input can be achieved (i.e. time delays, combinations, voltage level detection, etc.). By using ICCS Micro CAN, the module can directly handle CAN orders or accomplish logic locally in addition to CAN information (i.e. proximity sensor, voltage level detection, etc.).

Central Electrical Unit Power Logic Module

Dimensions

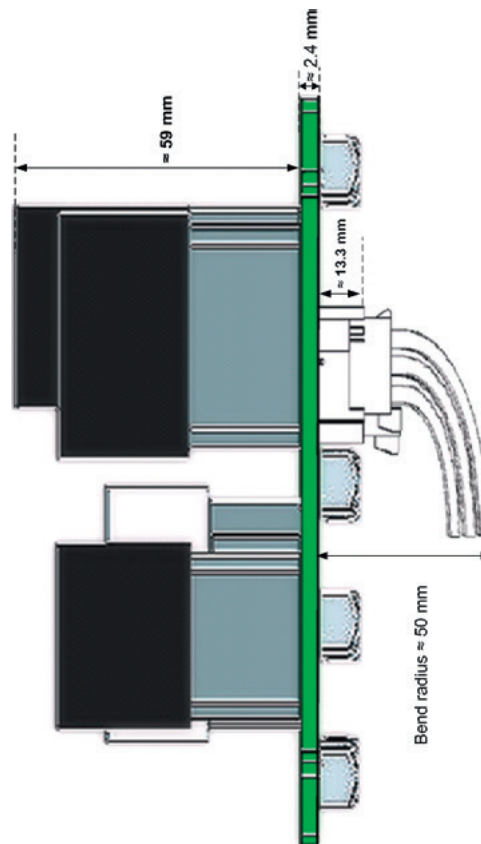
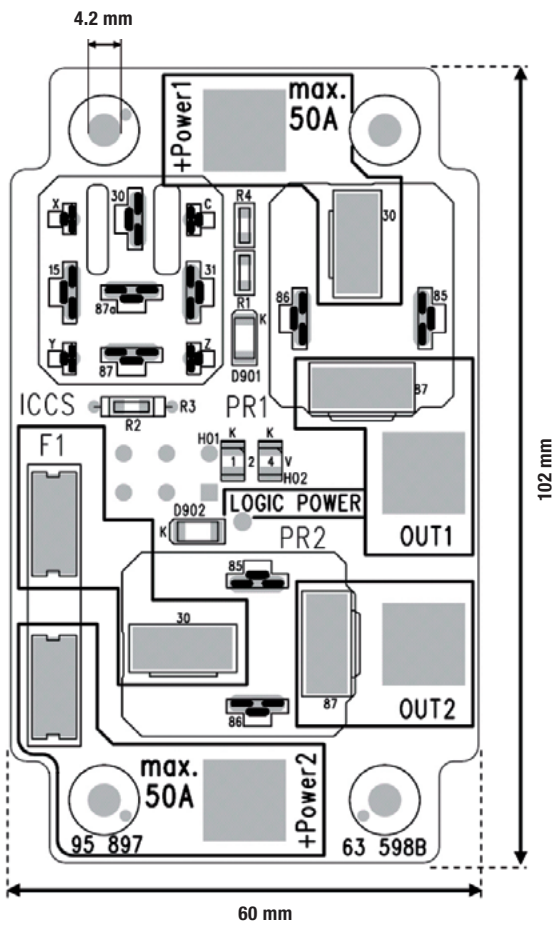

Approximate component size (depending on components)

Technical Data

Temperature range	-40 °C to +80 °C
Max. supply current	Max. 50 A by 50 °C ambient
Board or system connection	JPT/MCP compatible: 3-row, 6-way connector
Input / Output connection (power stud)	Powerelement female M5, 16 pins Max. mounting torque: 2.2 Nm



Central Electrical Unit Power Logic Module

Electrical Schematic

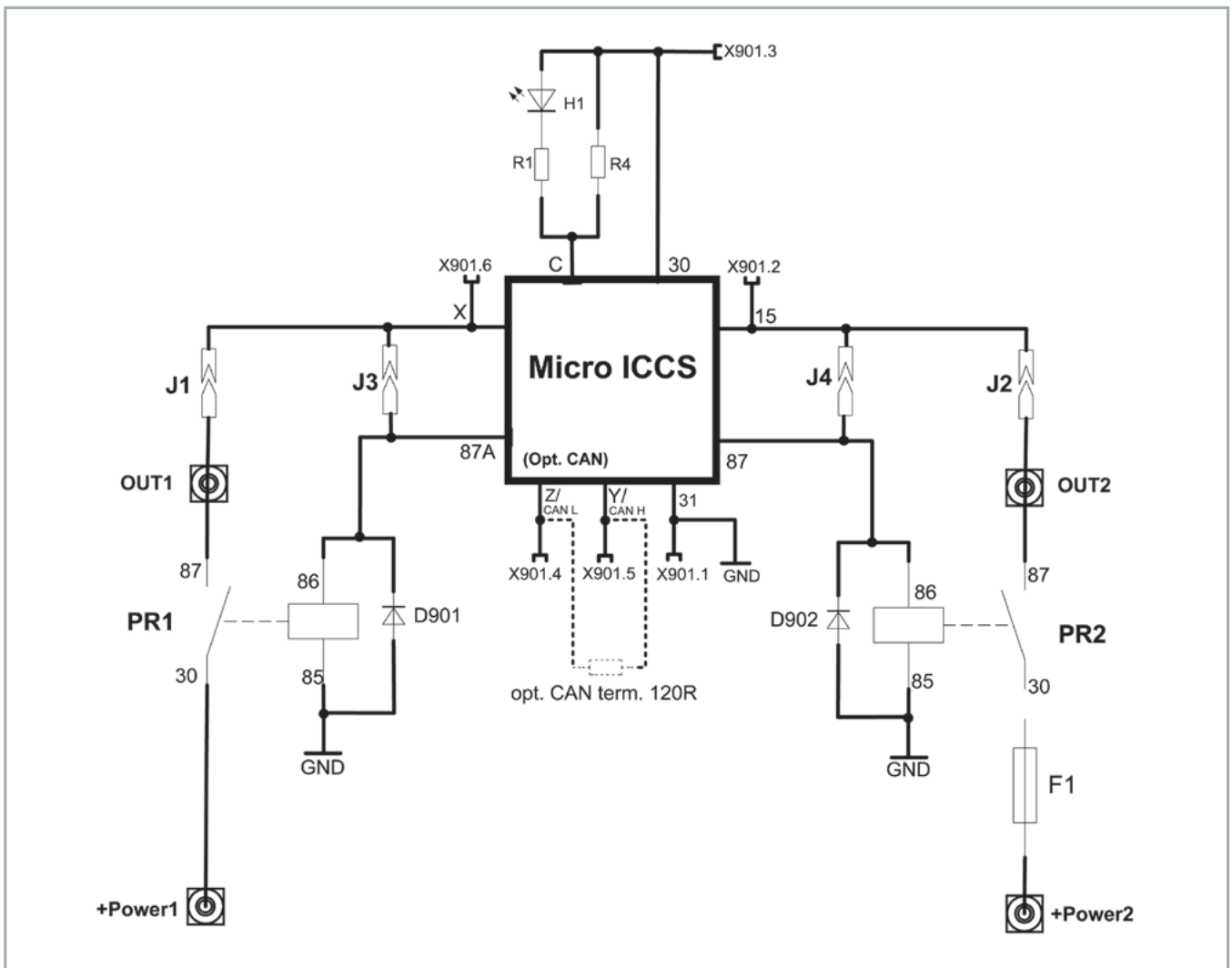

Central Electrical Unit

Power Logic Module

Connector: JPT 6 blue (X901)

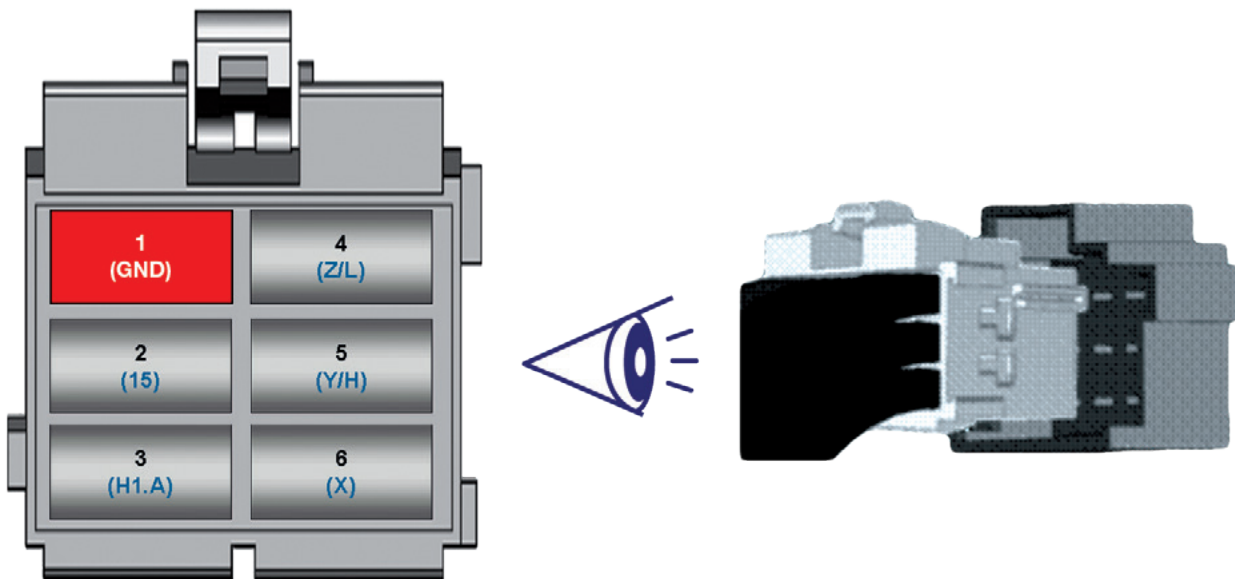

Female connector is required for cable harness connection (view on cable entry)

Pin-out on the connector corresponds to the associated component on the board (i.e. potential GND is connected to pin 1 from connector X901).

Jumper/Solder Bridge Function

To give the maximum flexibility to the function, we have integrated some soldering bridges to enable some specific behavior which can be tuned through the ICCS programming or board use.

Bridge Reference	Function
J1	Voltage feedback from PR1 output (87) to Micro ICCS input X
J2	Voltage feedback from PR2 output (87) to Micro ICCS input 15
J3 use when no ICCS populated	Connection between connector's pin 6 to PR1 coil (86) and also ICCS pin X
J4 use when no ICCS populated	Connection between connector's pin 2 to PR2 coil (86) and also ICCS pin 15



Use those bridges with care; may cause a back feed to connector or ICCS module.