

# Using Common Mode Chokes to Improve EMI Performance in Automotive Data Buses

Digital WE Days 2025  
Virtual Conference



Arturo Mediano  
*Founder & EMI/EMC magician*  
**HF MAGIC LAB S.L.**  
[amediano@hfmagiclab.com](mailto:amediano@hfmagiclab.com)



Prof. Arturo Mediano  
**I3A, UNIVERSITY OF ZARAGOZA (SPAIN)**  
[amediano@unizar.es](mailto:amediano@unizar.es)

Organized by,



**WÜRTH  
ELEKTRONIK**

2025

October 22<sup>th</sup>, 2025

# A High Frequency Lab for design, diagnostic, troubleshooting and training

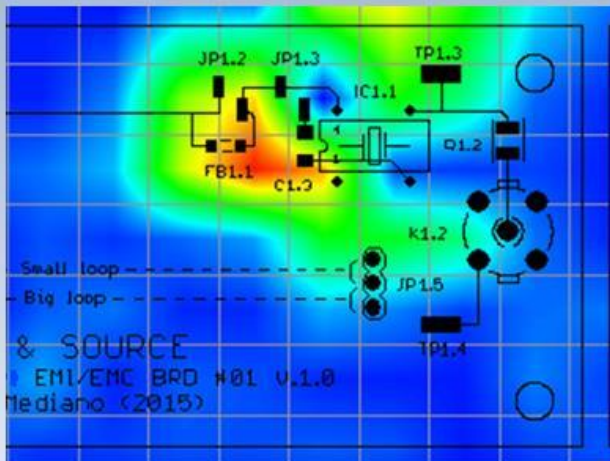

Interferences (EMI)  
Electromagnetic Compatibility (EMC)  
Signal Integrity (SI)  
Radiofrequency (RF)

Contact: Arturo Mediano  
HF MAGIC LAB S.L.

Bari, 31. Edificio TechnoCenter. Oficinas 216-217  
50197 Zaragoza (Spain)  
amediano@hfmagiclab.com

# About the speaker ...

## ARTURO MEDIANO – HF MAGIC LAB S.L.



- Faculty member at the University of Zaragoza (SPAIN) for >30 years
- Founder HF Magic Lab S.L.
- Senior Member IEEE
- Chair IEEE EMC-S Spain Chapter
- Past Chair IEEE MTT-S Technical Committee 17
- [amediano@unizar.es](mailto:amediano@unizar.es)
- [amediano@hfmagiclab.com](mailto:amediano@hfmagiclab.com)

# About this presentation ...

Modern vehicles use high-speed data buses (CAN, LIN, FlexRay, etc).

As data rates and electronic complexity increase, EMI poses a significant challenge.

Common Mode Chokes (CMCs) are essential for suppressing EMI, enhancing system immunity, and ensuring signal integrity in automotive applications.

This presentation will cover:

- **What a common mode choke is** and how it works.
- **How CMCs mitigate radiated emissions** and immunity problems.
- A **live demonstration** showing practical effects of CMCs on a CAN data bus.
- **Live Q&A session** with the speaker at the end of the presentation.

# Outline ...

- 1. Current: DM and CM.**
- 2. Filtering DM and CM.**
- 3. DM vs CM chokes.**
- 4. CM choke basic requirements**
- 5. Example of CM choke for signals**
- 5. Demo**
- 6. Conclusions**

# Current ... DM and CM

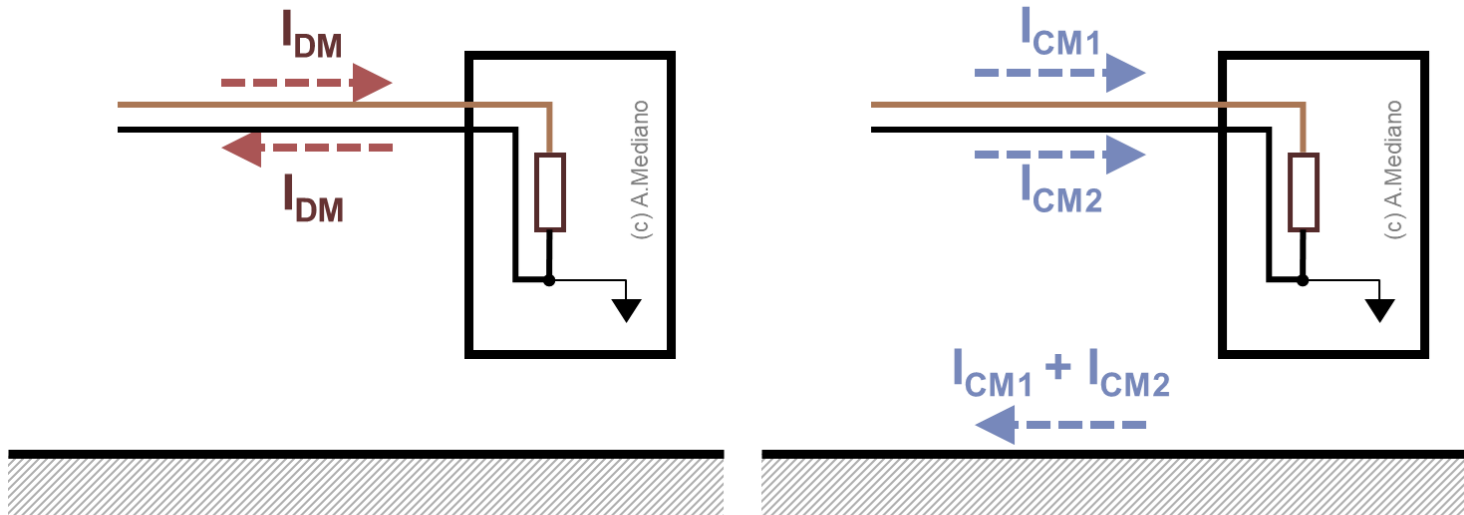

## Differential-mode (DM)

Usually not big loops  
Not very efficient antenna  
mA = problems

## Common-mode (CM)

Uncontrolled paths  
Very efficient antennas  
 $\mu$ A = problems

# Filtering ... DM vs CM

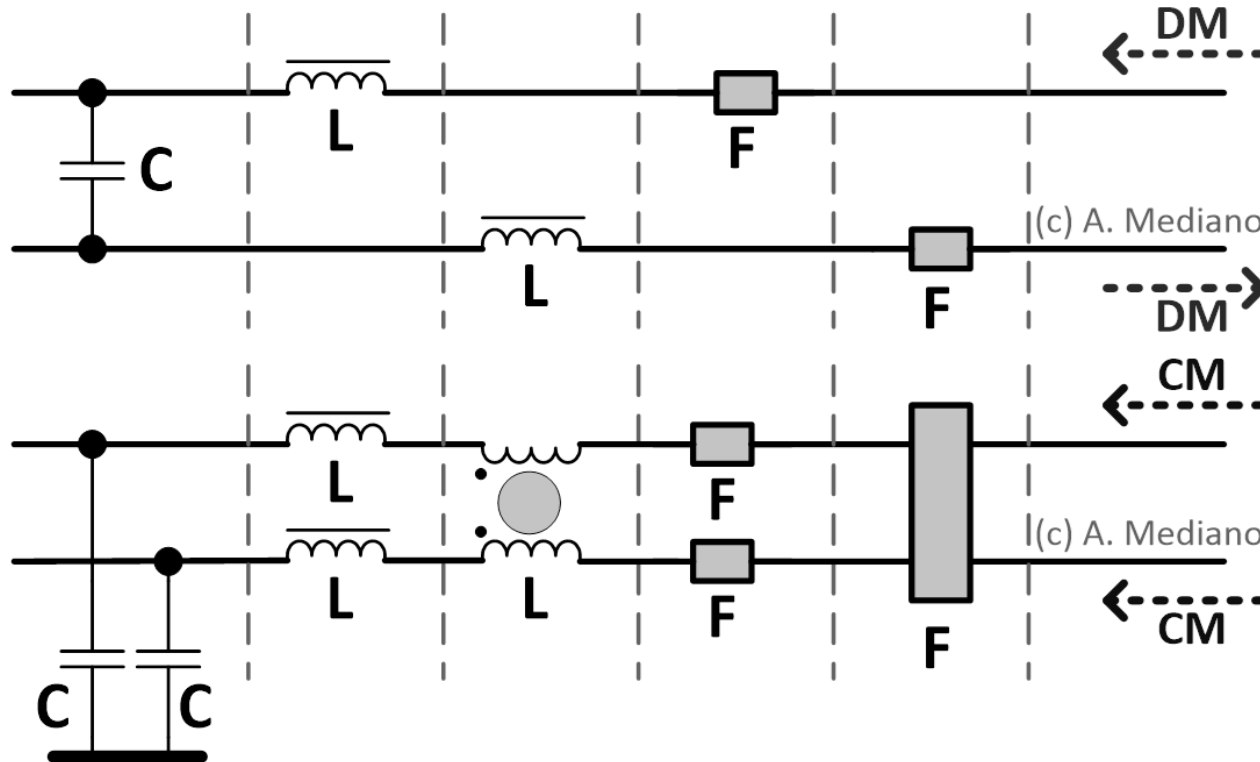

# Filtering ... DM vs CM chokes



WE-FI Leaded Toroidal Line Choke

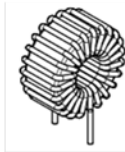

Part 7447026

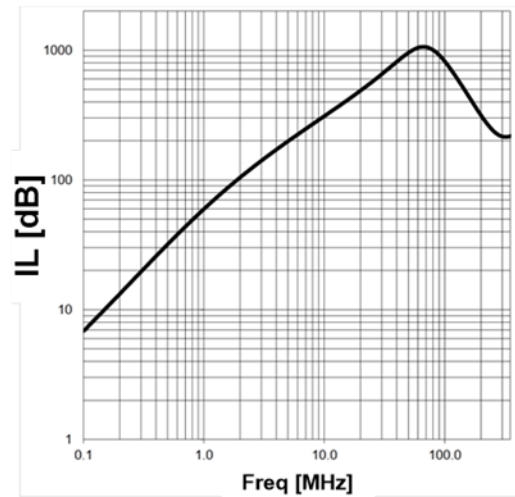

WE-CMB Common Mode Power Line Choke

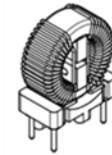

Part 744821201

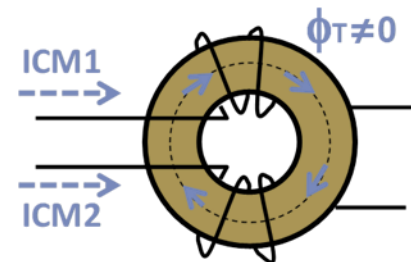
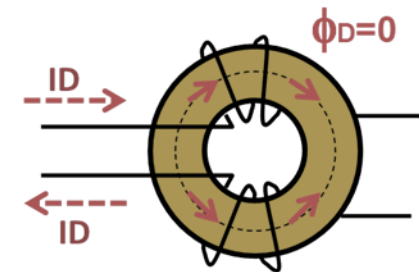
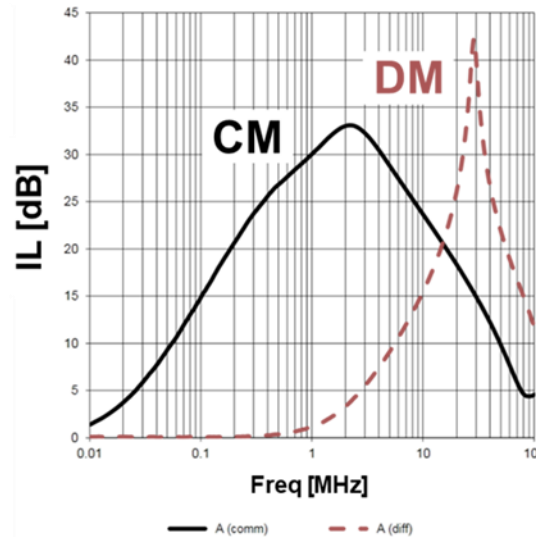

# CM chokes... basic requirements.

CM chokes for data lines requirements:

- **You need the choke filtering EMI in CM (i.e. S21 CM)**
- **Desired signal distortion must be avoided (i.e. S21 DM)**

so check compatibility EMI FILTER vs SIGNAL INTEGRITY

Three important parameters:

**Attenuation** you need.

**Frequency range** to be filtered

**Frequency range** for desired signal

**Saturation** current

# CM choke ... example for signals

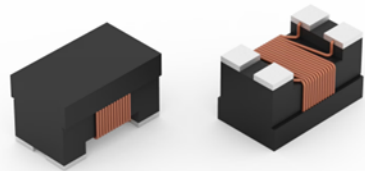

## Electrical Properties:

Properties	Test conditions	Value	Unit	Tol.
Inductance	L	51	$\mu\text{H}$	+50%/-30%
Impedance @ 100 MHz	Z 100 MHz	7850	$\Omega$	$\pm 25\%$
Rated Current	$I_R$ $\Delta T = 40 \text{ K}$	200	mA	max.
DC Resistance	$R_{DC}$ @ 20 °C	0.7	$\Omega$	max.
Insulation Test Voltage	$V_T$	125	V (DC)	
Rated Voltage	$V_R$	80	V (DC)	max.

**784234510** ✕  
WE-CNSA · 1210  
7.85 k $\Omega$  · 200 mA · bifilar

**784234101** ✕  
WE-CNSA · 1210  
9.93 k $\Omega$  · 100 mA · bifilar

**784234201** ✕  
WE-CNSA · 1210  
10.6 k $\Omega$  · 70.0 mA · bifilar

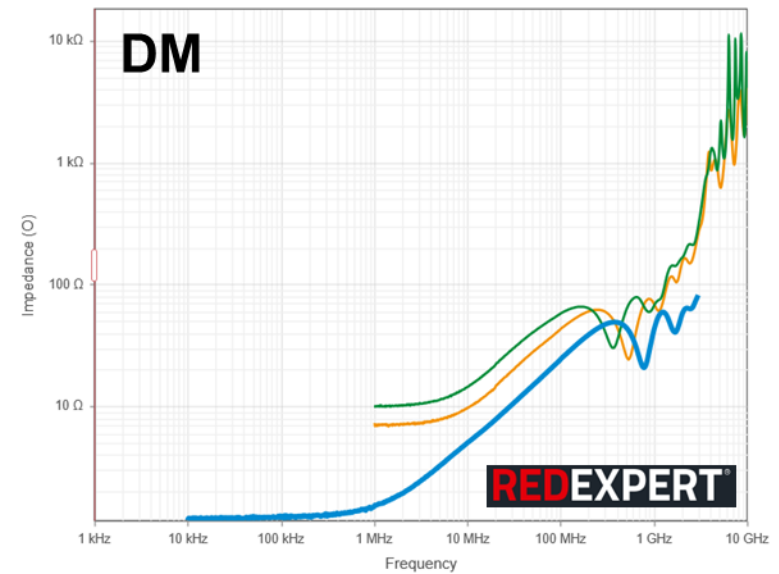
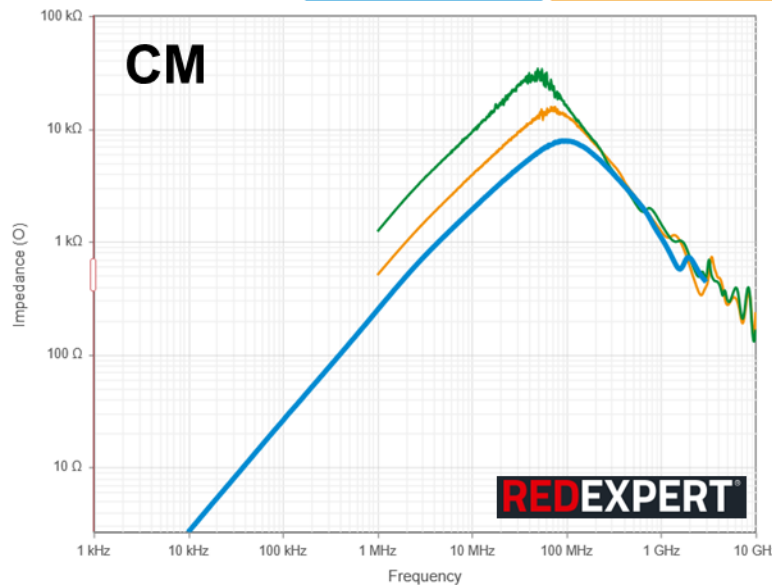
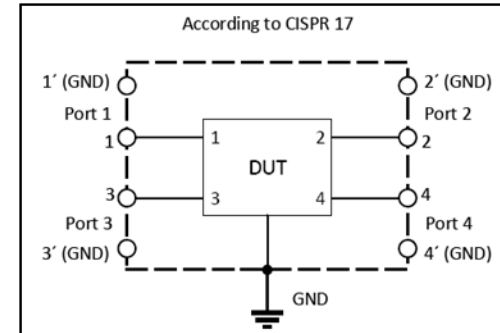

# DEMO... CM in CAN bus

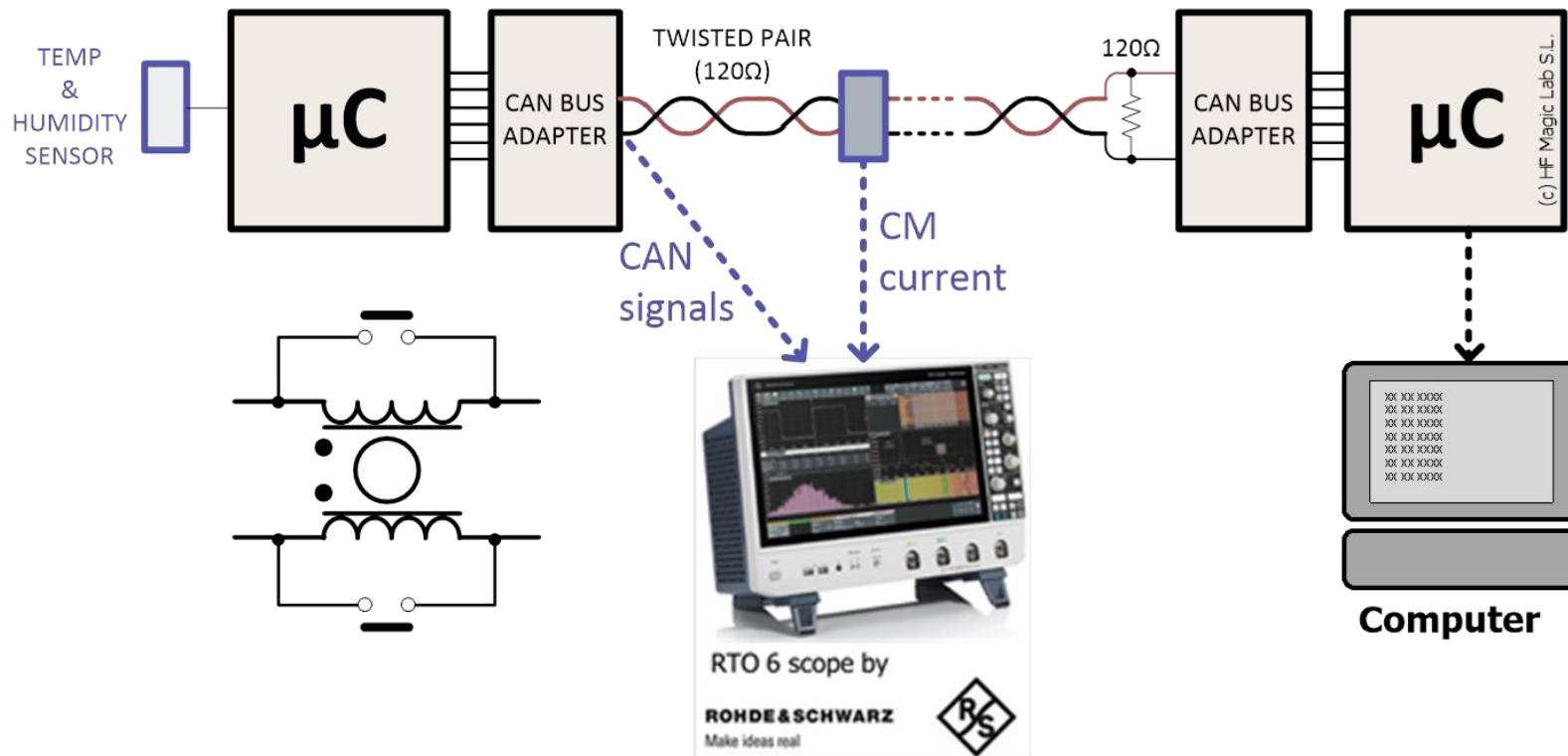

# THANK YOU!



Arturo Mediano  
*Founder & EMI/EMC magician*  
**HF MAGIC LAB S.L.**  
amediano@hfmagiclab.com



Prof. **Arturo Mediano**  
I3A, **UNIVERSITY OF ZARAGOZA (SPAIN)**  
amediano@unizar.es



**WÜRTH  
ELEKTRONIK**