

ICCS – Intelligent Control and Command Systems



Micro Gateway

ICCS Micro Gateway – Connection of CAN networks with different bit rates or protocols

The relay shape design provides connections for an analogue input, 2x CAN high speed and optionally a LIN bus interface. CAN messages of a network part can be received, filtered, edited and transferred to a connected subnetwork. Through the use of implementation and filtering rules, there is the option of a protocol adaptation between the subnetworks. The additional LIN bus connection (optional) enables data exchange between LIN and CAN networks.

Applications

- CAN bridge
- CAN message filtering
- LIN to CAN gateway
- LIN master or slave mode
- Connection of CAN-systems with different bus speeds
- Signal manipulation, event triggered suppressing and sending messages
- Connection of LIN sensor to the CAN bus, for example LIN rain, light, or battery sensor

Technical data

General information	
Connector	9 Pins DIN
Dimensions	30 x 30 x 50 mm
Weight	~30g
Operating temperature	-40 °C to 85 °C
Storage temperature	-40 °C to 85 °C
EMC	E1
Ingress protection	IP 53
Operating voltage Vsupply	9 to 30 V DC (CAN-CAN) 12 V or 24 V DC (CAN-CAN-LIN)
Pre-fusing	1 A
Current consumption	60 mA
Sleep mode consumption	< 1 mA
Processor type	Freescale HCS12 XEG
Clock frequency	100 MHz
Flash memory	128 kB
RAM	12 kB
EEPROM	1 kB available for graphical programming

CAN Bus

acc. ISO 11898-5	High speed wake on CAN
acc. CAN 2.0B	29 Bits extended address identifier
acc. CAN 2.0A	11 Bits standard address identifier
Baud rate	20 kBit/s to 1000 kBit/s (125kBit/s default value)

Inputs/outputs overview

1	Analogue input	0-33.67 V DC 12 Bits
1	Digital input	KL15 activation pin
1	LIN Bus	Optional LIN master

Inputs/outputs details

Analogue inputs

Input voltage max	Vsupply
Measuring range	0-33.67 V DC
Resolution	12 Bit
Input resistance	66.68 kΩ
Input frequency	max 50 Hz

LIN Bus (opt)

Pull up to Vsupply	1 kΩ with protection diode
Implementation	acc. LIN 2.1

ICCS Micro Gateway



Hardware Map

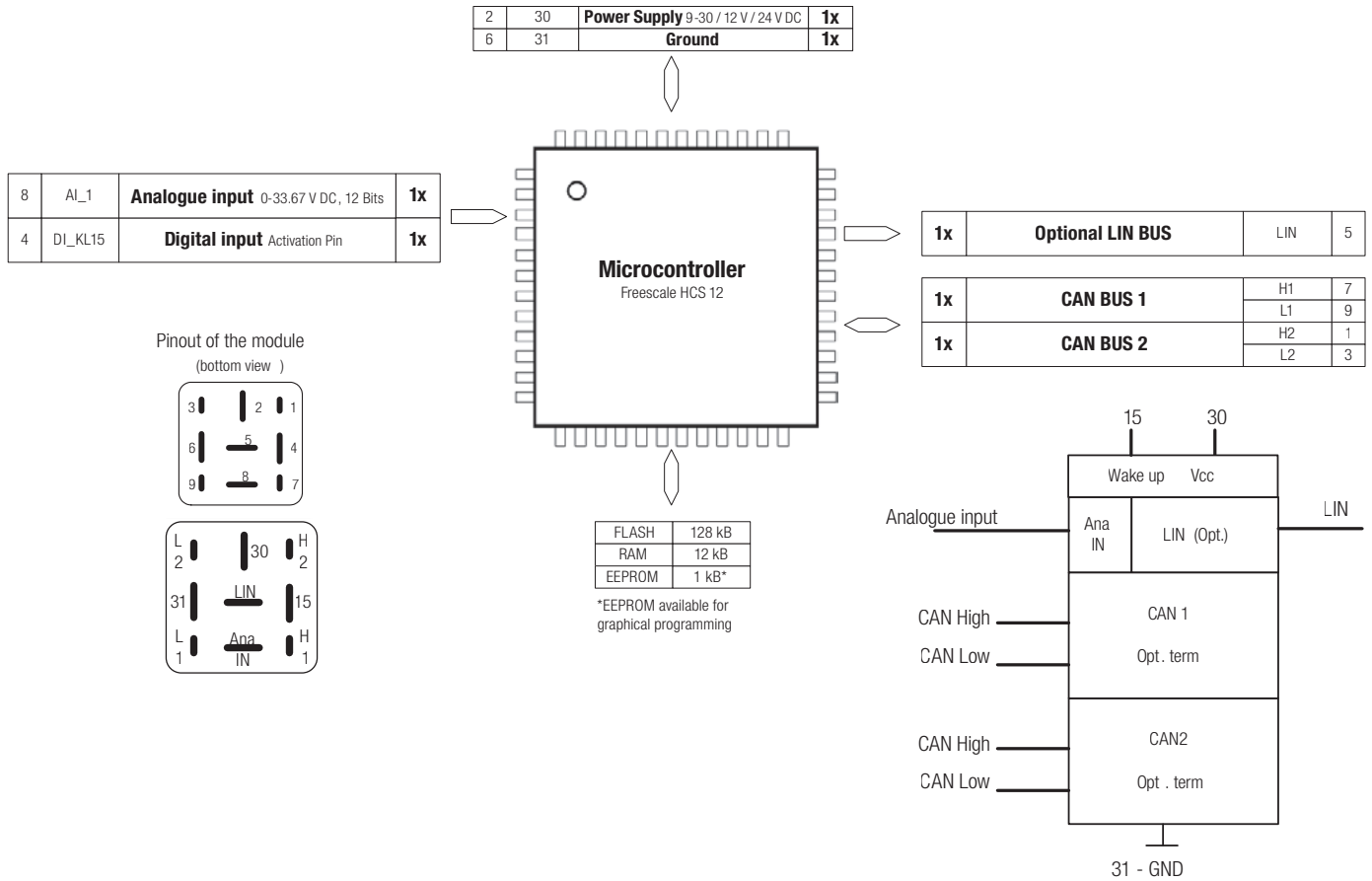

Pin assignment

Connector Micro Gateway		
PIN	Description	Function
1	H2	CAN Bus 2 High
2	30	Vcc Main Power Supply 9-30 V DC / 12 V / 24 V DC
3	L2	CAN Bus 2 Low
4	15	KL15 Activation pin
5	LIN (opt.)	Optional LIN Bus
6	31	Ground
7	H1	CAN Bus 1 High
8	Ana In	Analogue input 0-30 V
9	L1	CAN Bus 1 Low

Order information

Available references	Part number WE ICS
ICCS Micro Gateway 2 x CAN	ICS-97208
ICCS Micro Gateway 2 x CAN with CAN terminators	ICS-97227
ICCS Micro Gateway 2 x CAN – 1 x LIN master 12 V	ICS-97237
ICCS Micro Gateway 2 x CAN – 1 x LIN master 24 V	ICS-104065

This item is a standard product, please consider the relevant datasheet notes.
The user is responsible for the product's functionality in its purposed system environment.

Dimensions



For more information visit us at www.we-online.com or call +49 7940 9810-0.

Würth Elektronik ICS GmbH & Co. KG
Intelligent Power & Control Systems
 Gewerbepark Waldzimmern
 Würthstraße 1
 74676 Niedernhall · Germany
 Tel. +49 7940 9810-0
 Fax +49 7940 9810-1099
 ics@we-online.de
 www.we-online.com