



ADI Power

Power Supply Design using ADI power toolchain

Thorsten Block
FAE
Thorsten.Block@analog.com

analog.com

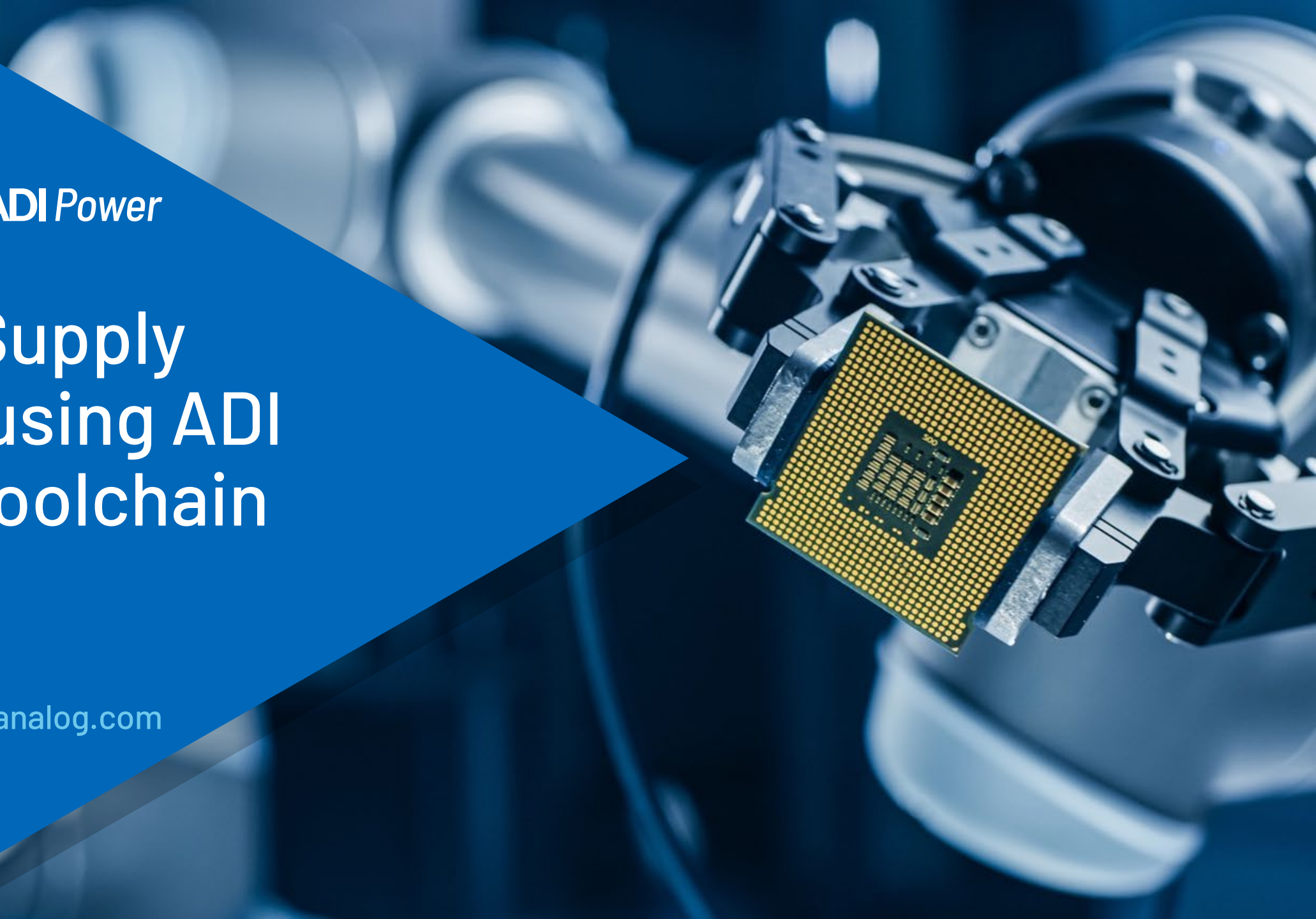

Closing the Loop on Power Supply Design!

LTpowerPlanner

System Level Power Tree

LTpowerCad

Search/Select a Solution Circuit Parameter Design

LTspice

Simulation

LTpowerAnalyzer

Power Lab

Homepage

LTpowerCAD[®] Resources Help

Supply Design Bench Testing Simulation System Design EE-Sim Selector

Open File Toolbox Contact Sync/Release

LTpowerCAD II Design Tool **V2.7.6**
Copyright © 2021, Analog Devices Inc. All rights reserved. LTpowerCAD@analog.com

ANALOG DEVICES
AHEAD OF WHAT'S POSSIBLE™



LTpowerPlanner

LTpowerPlanner- System Level Power Architecture Design Tool

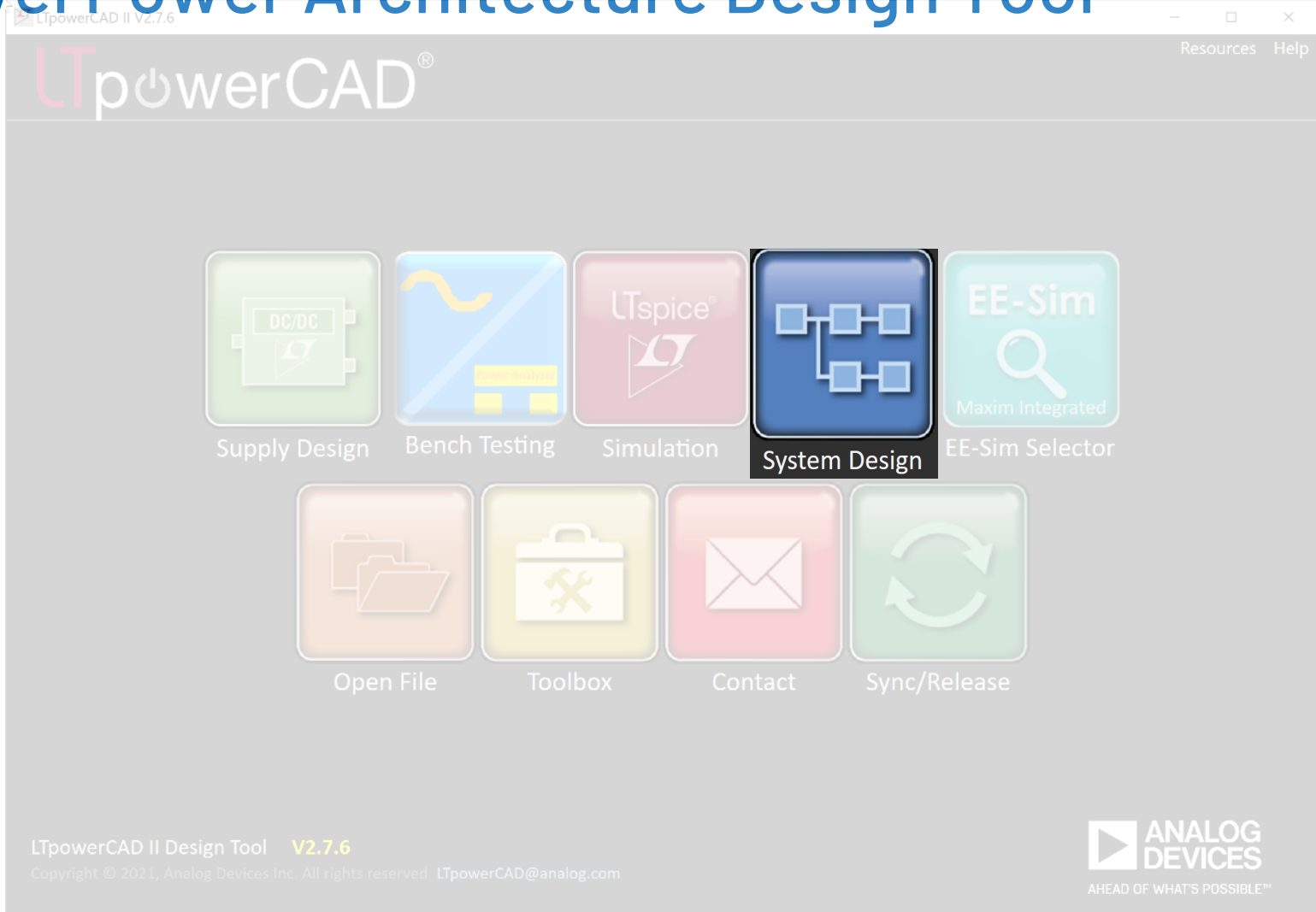

LTpowerPlanner- System Level Power Architecture Design Tool

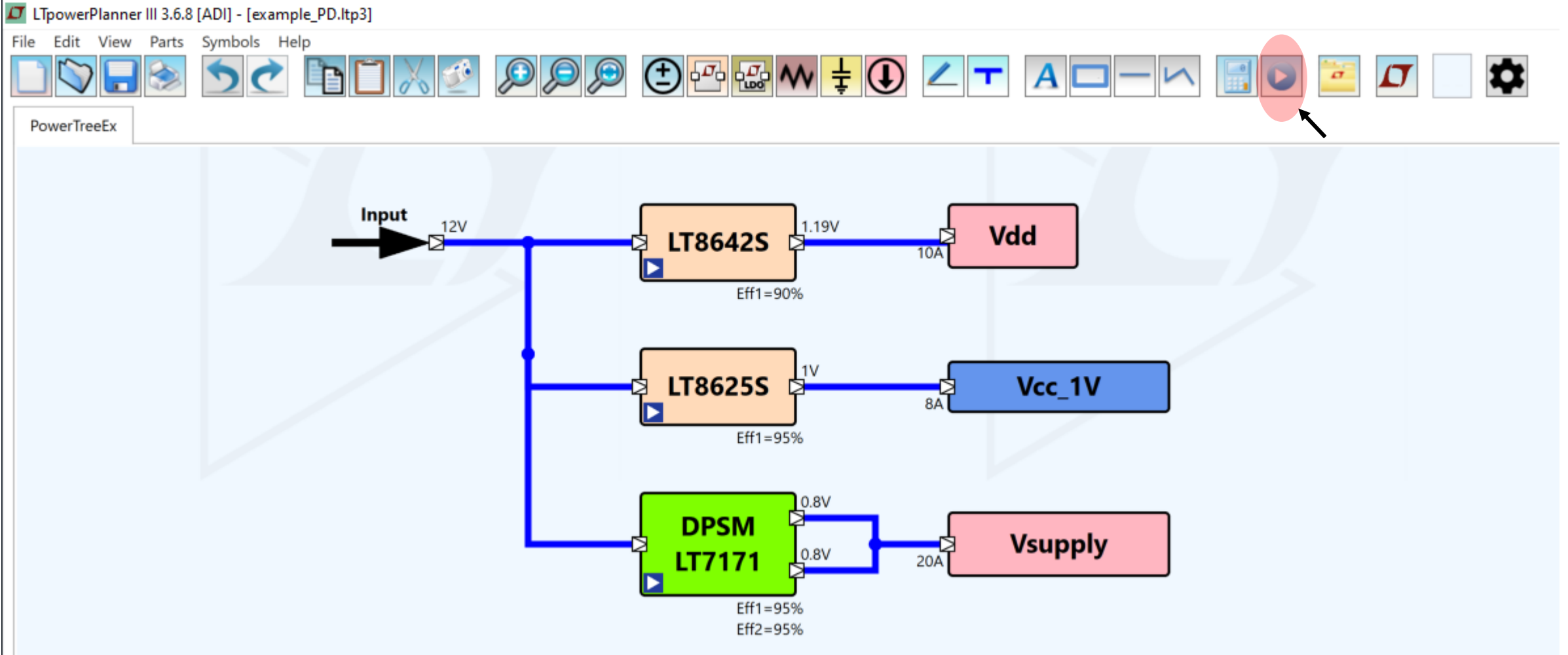

LTpowerPlanner- System Level Power Architecture Design Tool

File Edit View Parts Symbols Help

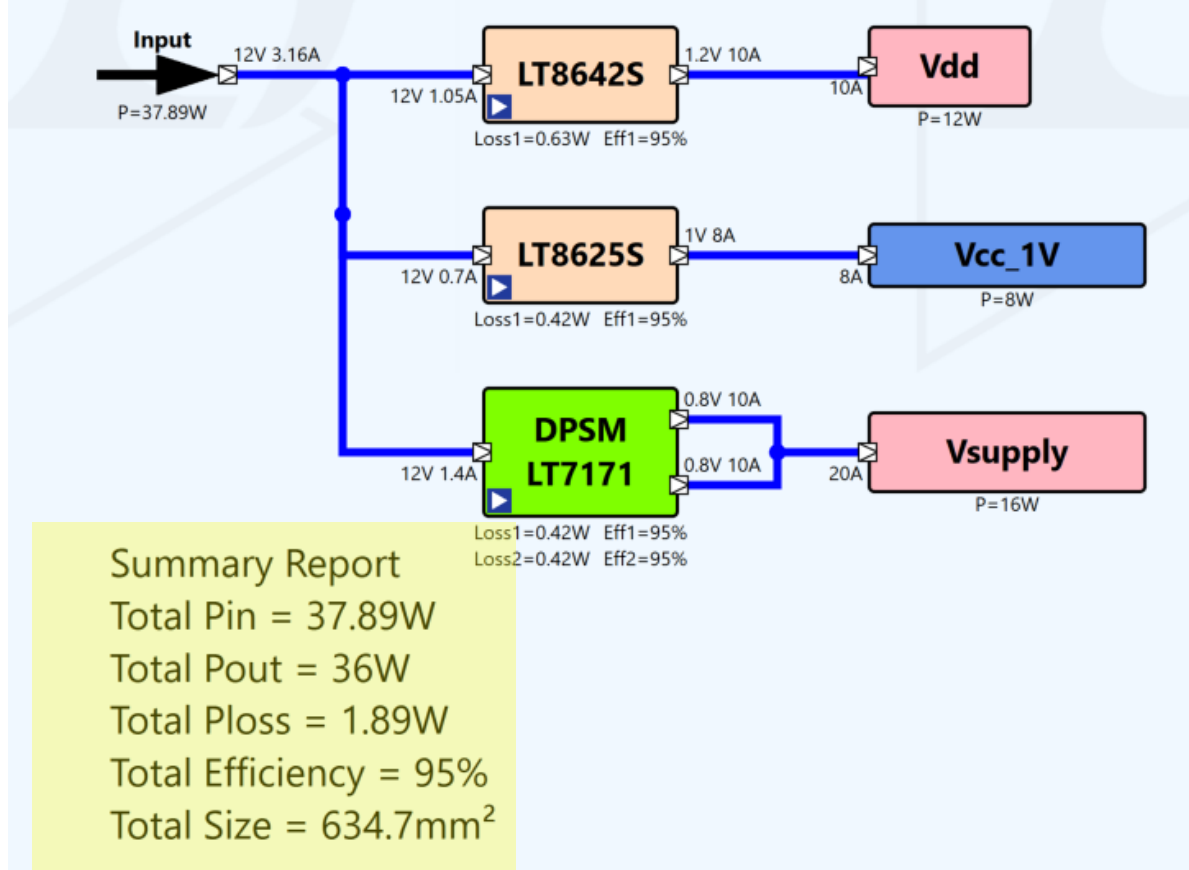

Comparing Different Power Tree Architectures

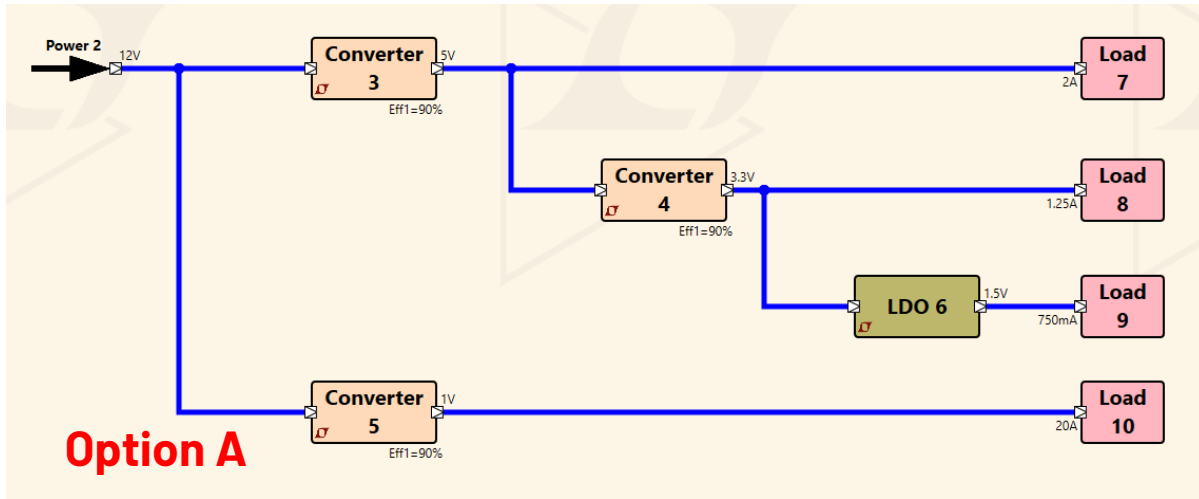

Summary Report
 Total Pin = 41.48W
 Total Pout = 35.25W
 Total Ploss = 6.23W
 Total Efficiency = 84.98%

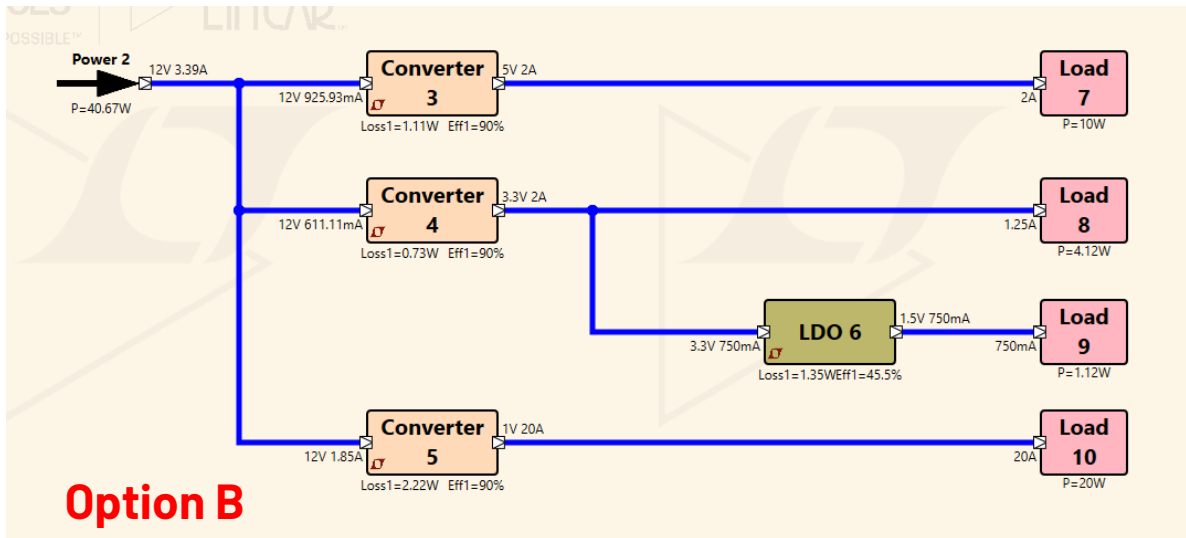

Summary Report
 Total Pin = 40.67W
 Total Pout = 35.25W
 Total Ploss = 5.42W
 Total Efficiency = 86.68%

LTpowerPlanner: LTpowerCAD and LTSPICE

Converter

Name: Color:

IC Part #: Solution Size (x): mm

Vin Min: **V** Solution Size (y): mm

Vin Max: **V** Solution Height: mm

Frequency: kHz Solution Area: mm²

Topology: **Converter Type:**

Output 1 +

Vout: **V** Vout Min: V

Iout Max: **A** Vout Max: V

Manually Enter Efficiency **Eff Nom:** %

Eff Peak: %

Clear

Visual: Label Size / Color:

Comments

Use as Title

LTpowerCAD File: [LT8642S_example.ltpc](#)

LTSpice File: [LT8642S_example.asc](#)

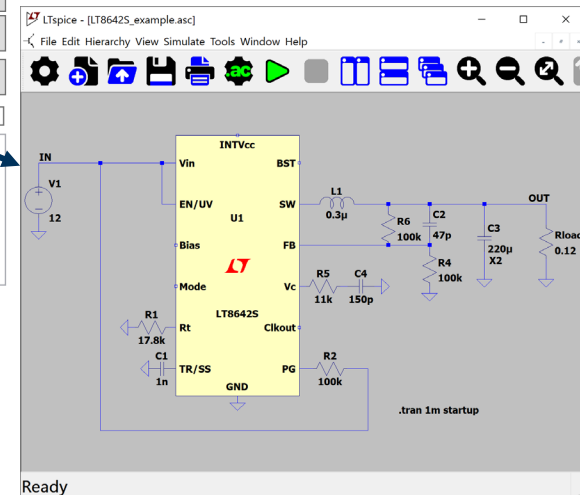
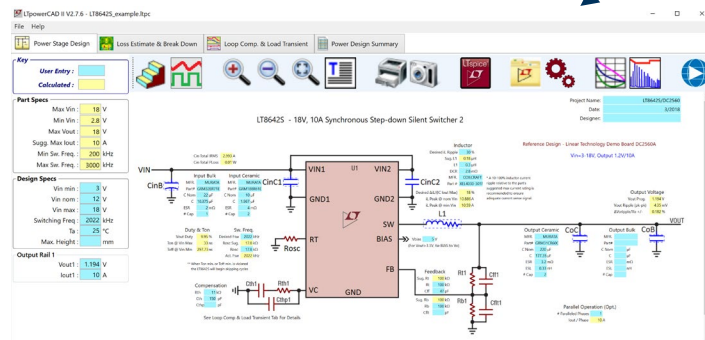

LTpowerCAD

LTpowerCAD: Power Supply Design in 5 Easy Steps

LTM4638	Buck
LTM4640	Buck
LTC7151S	Buck
LTC7150S	Buck
LT8648S	Buck
LTC3613	Buck
LT7170-1	Buck
LT7170	Buck
LT8627SP	Buck
MAX8655	Buck

Product Selection

Schematic
(warnings, suggest)

Optimize Efficiency

- Control Fet Conduction (0.479W,24.2%)
- Control Fet Turn On (0.056W,2.83%)
- Control Fet Turn Off (0.039W,1.97%)
- Control Fet Driving (0.013W,0.66%)
- Sync Fet Conduction (0.199W,10.06%)
- Sync Fet Driving (0.06W,3.03%)
- Sync Fet Body Diode (0.189W,9.55%)
- Inductor DCR (0.424W,21.42%)
- Inductor AC (0.2W,10.11%)
- Cap Losses (0.31W,15.68%)

Optimize Transient, Loop

LT8642S Supply Design Summary

Project Info:

Steady State:

Rail #	Vin Min.	Vin Nom.	Vin Max.	Fsw	Vo
1	10 V	12 V	15 V	300 kHz	0.9 V

Efficiency and Loop:

Rail #	Vo	Iomax	Eff.@Iomax	Ploss@Iomax	Loop
1	0.9 V	10 A	86.74 %	1.38 W	31.62

Recommendations and Warnings:

Message

Power Components Bill Of Materials:

Ref. Des.	Value	Quantity	Description	Mfr. Name
U1		1	IC	LINEAR TECH
Lo1	0.52uH	1	IND	COILCRAFT
CinC1	22uF	1	CAP	WURTH
Coc1 Coc2	220uF	2	CAP	MURATA

Power Components Footprint:

Components: 5
Max. Height: 3.2 mm

Free download @ www.analog.com/LTpowerCAD

LTpowerCAD - Supply Design

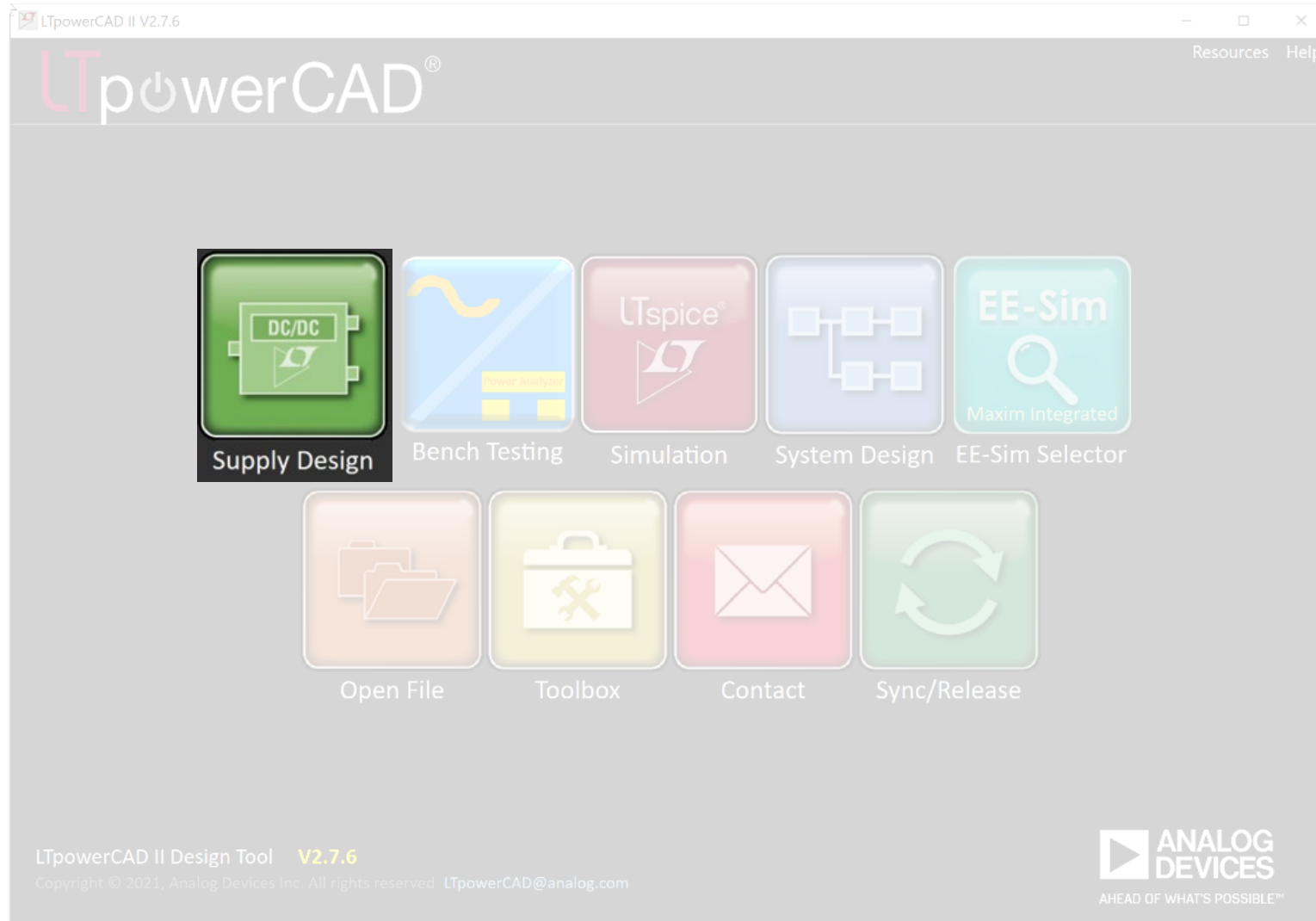

Product Selection Page

Monolithic: Top and Bottom MOSFET are integrated in the part.
uModule: Top and Bottom MOSFET, inductor, and in some cases CIN/COU are integrated.

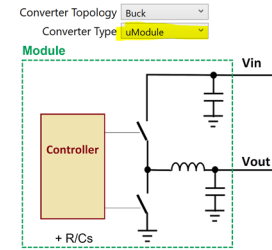

LTpowerCAD Part Search

Converter Specification

Input: Vin min. 10.8 V, Vin nom. 12 V, Vin max. 13.2 V

Output 1: Vout1 1.2 V, Iout1 10 A

Outputs: One

Max. Paralleled: 1

Enter Fsw. Recommended

Frequency Fsw. kHz

Max. Height mm

[Search Parts](#)

Converter Topology Buck

Converter Type Monolithic

Monolithic IC

Controller

+ R/Cs

Optional Features

- Synchronous
- Run / Enable
- Parallel Outputs
- Silent Switcher / Low EMI
- PSM (12C / PMBus)
- Int. & Ext. Comp.
- DCM Capable
- MP Temp. Grade
- Ext. Clock
- Output Tracking
- Remote Sensing
- Power Good
- Automotive
- Margining
- Isolated

Search Options

All Parts

Keep Search Page Open

[Reset Search](#)

Find Part (###) [Go](#)

Datasheet Schematic

Pin Configuration

TOP VIEW

24-LEAD (4mm x 4mm x 0.94mm)

JEDEC BOARD: θJA = 38°C/W, θJC(PP2) = 7°C/W (NOTE 3)

ICAW BOARD: θJA = 24°C/W

EXPOSED PAD (PINS 25-28) ARE GND. SHOULD BE SOLDERED TO PCB

Design Tool (Click to Open)	Part #	Topology	Type	Description	Tot. IC Pkg. Area (mm ²)	Year Released	Product Weblink	Part Isw Max. (A)	Total Eff. @ 500kHz or min. (%)	Total Eff. @ 2MHz or max. (%)	Part Tj-Ta (C) (1st Order)	Part # Outputs	Part # Phases	Part Min. Vin (V)	Part Max. Vin (V)	Part Min
	LT8642S	Buck	Monolithic	18V, 10A Sync Step-Down Silent Switcher 2	16	2018	LT8642S	10	91.1	87.24	35.12	1	1	2.8	18	0.6
	LT8627SP	Buck	Monolithic	18V, 16A Sync Step-Down Silent Switcher with Ultra Low Noise	12	2021	LT8627SP	16	93.29	87.23		1	1	2.8	18	0
	LTC7151S	Buck	Monolithic	20VIN, 15A Synchronous Step-Down Regulator	20	2018	LTC7151S	15	93.16	88.25	19.82	1	1	3.1	20	0.5
	LT8638S	Buck	Monolithic	42V, 10A Sync Step-Down Silent Switcher 2	20	2021	LT8638S	10	89.07	79.92	42.63	1	1	2.8	42	0.6
	LT8648S	Buck	Monolithic	42V, 15A Sync Step-Down Silent Switcher 2	28	2019	LT8648S	15	90.83	79.21	32.7	1	1	3	42	0.6
	LTC7150S	Buck	Monolithic	20VIN, 20A Synchronous Step-Down Regulator	30	2017	LTC7150S	20	94.7	87	25.88	1	1	3.1	20	0.6
	LT7170	Buck	Monolithic	20 A, 16 V, Single Phase, Silent Switcher Step-Down Regulator with Digital Power System Management	14	2024	LT7170	20	94.58	88.32	24.46	1	1	2.9	16	0.4
	LT7171	Buck	Monolithic	20 A, 16 V, Single Phase, Silent Switcher Step-Down Regulator with Digital Power System Management	14	2024	LT7171	20	94.27	88.05	25.36	1	1	2.9	16	0.4

LT8642S Silent Switcher 2 Step Down Regulator

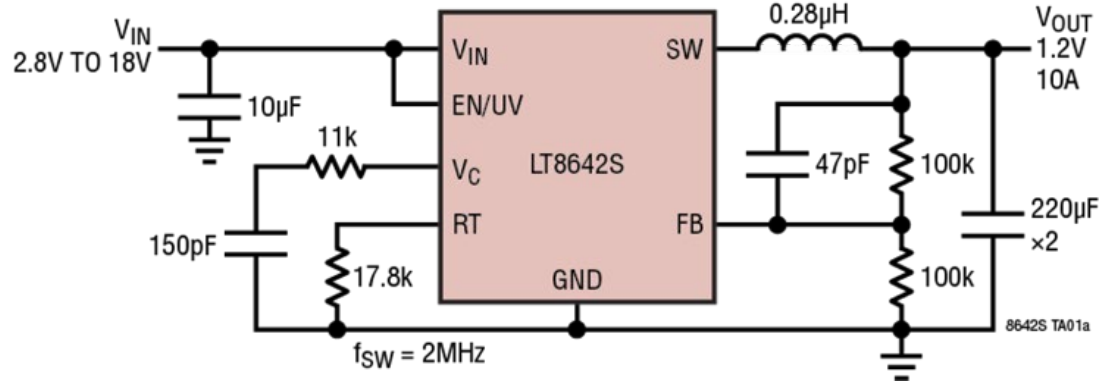

[DC2560A](#): 18V, 10A Evaluation Kit featuring the [LT8642S](#) Silent Switcher 2 step down regulator

Evaluation Kits

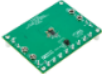

DC2560A

18V, 10A Synchronous Step-Down Silent Switcher 2



LTpowerAnalyzer

EVAL-LTPA-KIT | Low-cost, High Performance, Compact Laboratory Tool for Evaluating and Characterizing Power Supply Designs

Silent Switcher

- High efficiency
- High frequency
- Low EMI

Silent Switcher 2

- Lower EMI
- Decrease PCB layout sensitivity
- Smaller solution size

Silent Switcher 3

- Ultralow LF Noise (0.1 to 100kHz)
- Ultrafast Transient Response

LTpowerCAD: Power Supply Design in 5 Easy Steps

LTM4638	Buck
LTM4640	Buck
LTC7151S	Buck
LTC7150S	Buck
LT8648S	Buck
LTC3613	Buck
LT7170-1	Buck
LT7170	Buck
LT8627SP	Buck
MAX8655	Buck

Product Selection

Schematic
(warnings, suggest)

Optimize Efficiency

- Control Fet Conduction (0.479W,24.2%)
- Control Fet Turn On (0.056W,2.83%)
- Control Fet Turn Off (0.039W,1.97%)
- Control Fet Driving (0.013W,0.66%)
- Sync Fet Conduction (0.199W,10.06%)
- Sync Fet Driving (0.06W,3.03%)
- Sync Fet Body Diode (0.189W,9.55%)
- Inductor DCR (0.424W,21.42%)
- Inductor AC (0.2W,10.11%)
- Cap Losses (0.31W,15.68%)

Optimize Transient, Loop

Design Summary

Steady State:

Rail #	Vin Min.	Vin Nom.	Vin Max.	Fsw	Vo
1	10 V	12 V	15 V	300 kHz	0.9 V

Efficiency and Loop:

Rail #	Vo	Iomax	Eff.@Iomax	Ploss@Iomax	Loop
1	0.9 V	10 A	86.74 %	1.38 W	31.62

Power Components Bill Of Materials:

Ref. Des.	Value	Quantity	Description	Mfr. Name
U1		1	IC	LINEAR TECH
Lo1	0.52μH	1	IND	COILCRAFT
Cin1	22μF	1	CAP	WURTH
Coc1 Coc2	220μF	2	CAP	MURATA

Free download @ www.analog.com/LTpowerCAD

LTpowerCAD Power Stage Design Overview

Power Stage Design | Loss Estimate & Break Down | Loop Comp. & Load Transient | Power Design Summary

Key
 User Entry: [Light Blue]
 Calculated: [Yellow]

Part Specs
 Max Vin: 18 V
 Min Vin: 2.8 V
 Max Vout: 18 V
 Sugg. Max Iout: 10 A
 Min Sw. Freq.: 200 kHz
 Max Sw. Freq.: 3000 kHz

Design Specs
 Vin min: 10.8 V
 Vin nom: 12 V
 Vin max: 13.2 V
 Switching Freq: 201 kHz
 Ta: 25 °C
 Max. Height: mm

Output Rail 1
 Vout1: 1.194 V
 Iout1: 10 A

Project Name: [Light Blue]
Date: [Light Blue]
Designer: [Light Blue]

LT8642S - 18V, 10A Synchronous Step-down Silent Switcher 2

Input Bulk
 MFR. [Light Blue]
 Part# [Light Blue]
 C Nom. μF [Light Blue]
 C μF [Light Blue]
 ESR mΩ [Light Blue]
 # Cap [Light Blue]

Input Ceramic
 MFR. WURTH
 Part# 88501210701
 C Nom. 22 μF
 C 5.547 μF
 ESR 4.83 mΩ
 # Cap 1

Inductor
 Desired iL Ripple 50 %
 Sug. L1 1.07 μH
 L1 1 μH
 DCR 2.55 mΩ
 MFR. COILCRAFT
 Part # XAL7070-102
 Desired ΔiL/(IC Iout Max) 53 %
 iL Peak @ nom Vin 12.675 A
 iL Peak @ min Vin 12.64 A

Output Voltage
 Vout Prog. 1.194 V
 Vout Ripple (pk-pk) 14.664 mV
 ΔVripple/Vo +/- 0.614 %

Duty & Ton
 Vout Duty 9.95 %
 Ton @ Vin Max 450 ns
 Toff @ Vin Min 4425.1 ns

Sw. Freq.
 Desired Fsw 200 kHz
 Rosc Sug. 226 kΩ
 Rosc 226 kΩ
 Act. Fsw 201 kHz

Compensation
 Rth 6.81 kΩ
 Cth 2700 pF
 Cthp 110 pF

Feedback
 Sug. Rt 100 kΩ
 Rt 100 kΩ
 Cff pF [Light Blue]
 Sug. Rb 100 kΩ
 Rb 100 kΩ
 Cflt pF [Light Blue]

Output Ceramic
 MFR. MURATA
 Part# GRM31CR60C
 C Nom. 220 μF
 C 177.35 μF
 ESR 3.2 mΩ
 ESL 0.01 nH
 # Cap 2

Output Bulk
 MFR. [Light Blue]
 Part# [Light Blue]
 C Nom. μF [Light Blue]
 C μF [Light Blue]
 ESR mΩ [Light Blue]
 ESL nH [Light Blue]
 # Cap [Light Blue]

Parallel Operation (Opt.)
 # Paralleled Phases 1
 Iout / Phase 10 A

Annotations:
 * A 10-100% inductor current ripple relative to the part's suggested max current rating is recommended to ensure adequate current sense signal.
 ** When Ton min. or Toff min. is violated the LT8642S will begin skipping cycles

See Loop Comp & Load Transient Tab For Details

LTpowerCAD Power Stage Design Overview

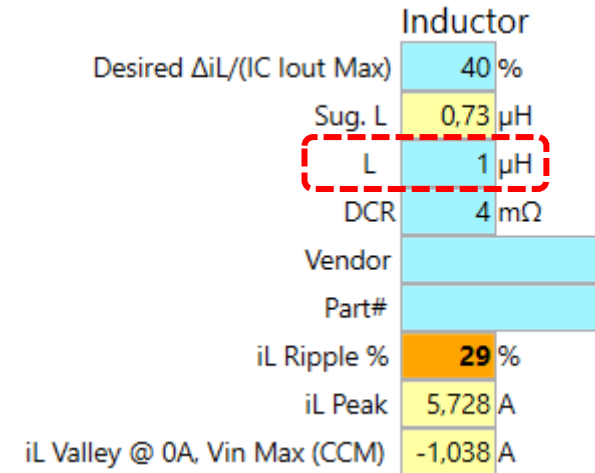
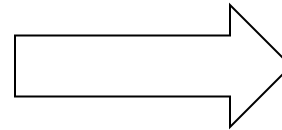
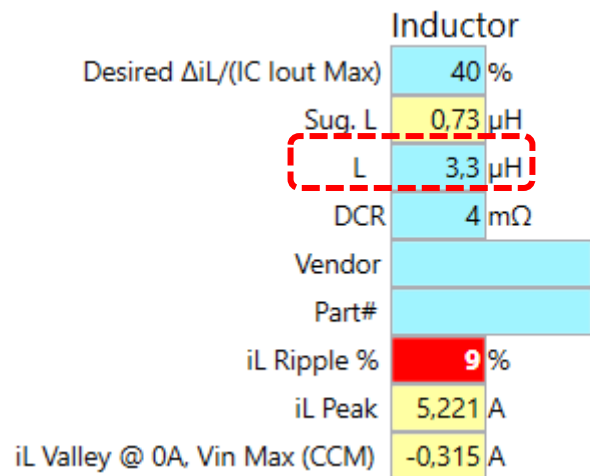

Strong Warning

"Soft" Warning

Enter Inductance close to suggested value.
 Then search for an inductor (inside LTpowerCAD or on vendor website)

Warning levels are set by application experts for different products.



Select Inductor (Component Library)

INDUCTOR Library

Options Search Settings

Show All Show Suggested Show Suggested w/ AC Loss Info

Key: Built-in Parts: User Parts:

Show Only AEC-Q Parts

* Loss values calculated at Vin nom. and Iout max.

Vendor	Name	L(μH)	L Tol(%)	DCR(mΩ)	DCR Tol(%)	I Sat(A)	L Dec.(%)	I Heat(A)	T Rise(C)	Core	L(mm)	W(mm)	H(mm)	V Max (V)	T Max (C)	AECQ200	Coupling Factor
WURTH	744340300025	0.02	15	0.27	15	45	30	52.9	40	MnZn	4.1	3.1	3	80	125	True	
WURTH	744340300030	0.03	15	0.27	15	44	30	52.9	40	MnZn	4.1	3.1	3		125	True	
WURTH	744340300055	0.055	15	0.27	15	24	30	52.9	40	MnZn	4.1	3.1	3		125	True	
WURTH	744028000056	0.056	30	11.5	30	6	35	4.5	40	NiZn	2.8	2.8	1.1		125	False	
WURTH	744300006	0.06	20	0.22	10	63	30	80.8	40	MnZn	8.64	6.35	4.5		125	True	
WURTH	744029000068	0.068	30	10.5	43	5.5	35	4.5	40	NiZn	2.8	2.8	1.35		125	False	
WURTH	74431012007	0.07	15	0.125	10	125	30	84.3	40	MnZn	10	6	12.1		125	True	
WURTH	74434035007	0.07	20	0.42	8	17	30	84	40	MnZn	4.15	3.1	3.5		125	True	
WURTH	744302007	0.072	20	0.24	6	60	20	30	50	ManganZn	6.95	6.8	4.5		125	False	
WURTH	744340300075	0.075	15	0.27	15	20	30	52.9	40	MnZn	4.1	3.1	3		125	True	
WURTH	744300008	0.08	20	0.22	10	51	30	80.8	40	MnZn	8.64	6.35	4.5		125	True	
WURTH	7443082010B	0.1	10	0.114	5	100	30	82.6	40	MnZn	10.2	8.2	8.5		125	False	
WURTH	74431012010	0.1	15	0.125	10	125	30	84.3	40	MnZn	10	6	12.1		125	True	
WURTH	744304010	0.1	20	0.17	7	52	20	26	50	ManganZn	11.5	11.8	3.8		125	False	
WURTH	7443082010	0.1	10	0.18	5	100	30	60	40	MnZn	10.2	8	8.1	80	125	True	
WURTH	744300010	0.1	20	0.22	10	42	30	80.8	40	MnZn	8.64	6.35	4.5		125	True	

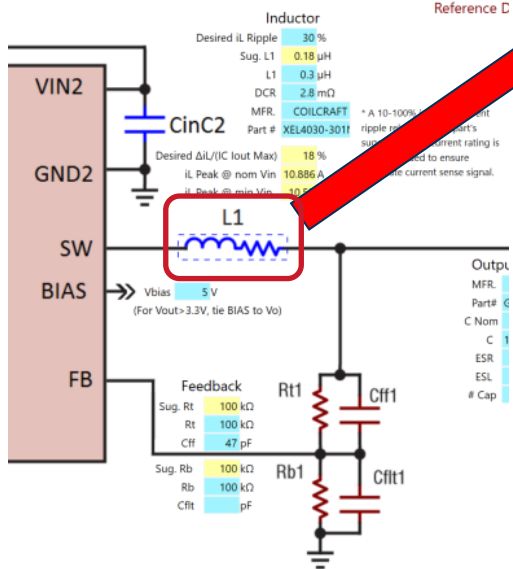

* So far only Wurth and Coilcraft provide AC loss estimations. Comparing AC loss between vendors may not be accurate due to different estimation methods.

Vendor Search Tools

Note* You can add your own inductor manually.

LTpowerCAD: Power Supply Design in 5 Easy Steps

LTM4638	Buck
LTM4640	Buck
LTC7151S	Buck
LTC7150S	Buck
LT8648S	Buck
LTC3613	Buck
LT7170-1	Buck
LT7170	Buck
LT8627SP	Buck
MAX8655	Buck

Product Selection

Schematic
(warnings, suggest)

Optimize Efficiency

Rail #1 (1.492V) Power Loss Breakdown (Full Load)

- Control Fet Conduction (0.479W, 24.2%)
- Control Fet Turn On (0.056W, 2.83%)
- Control Fet Turn Off (0.039W, 1.97%)
- Control Fet Driving (0.013W, 0.66%)
- Sync Fet Conduction (0.199W, 10.06%)
- Sync Fet Driving (0.06W, 3.03%)
- Sync Fet Body Diode (0.189W, 9.55%)
- Inductor DCR (0.424W, 21.42%)
- Inductor AC (0.2W, 10.11%)
- Cap Losses (0.31W, 15.68%)

Optimize Transient, Loop

Design Summary

LT8642S Supply Design Summary

Project Info:

Steady State:

Rail #	Vin Min.	Vin Nom.	Vin Max.	Fsw	Vo
1	10 V	12 V	15 V	300 kHz	0.9 V

Efficiency and Loop:

Rail #	Vo	Iomax	Eff.@Iomax	Ploss@Iomax	Loop
1	0.9 V	10 A	86.74 %	1.38 W	31.62

Recommendations and Warnings:

Power Components Bill Of Materials:

Ref. Des.	Value	Quantity	Description	Mfr. Name
U1		1	IC	LINEAR TECH
Lo1	0.52μH	1	IND	COILCRAFT
Cin1	22μF	1	CAP	WURTH
Coc1 Coc2	220μF	2	CAP	MURATA

Power Components Footprint:

Components: 5
Max. Height: 3.2 mm

Free download @ www.analog.com/LTpowerCAD

Loss Estimate & Break Down

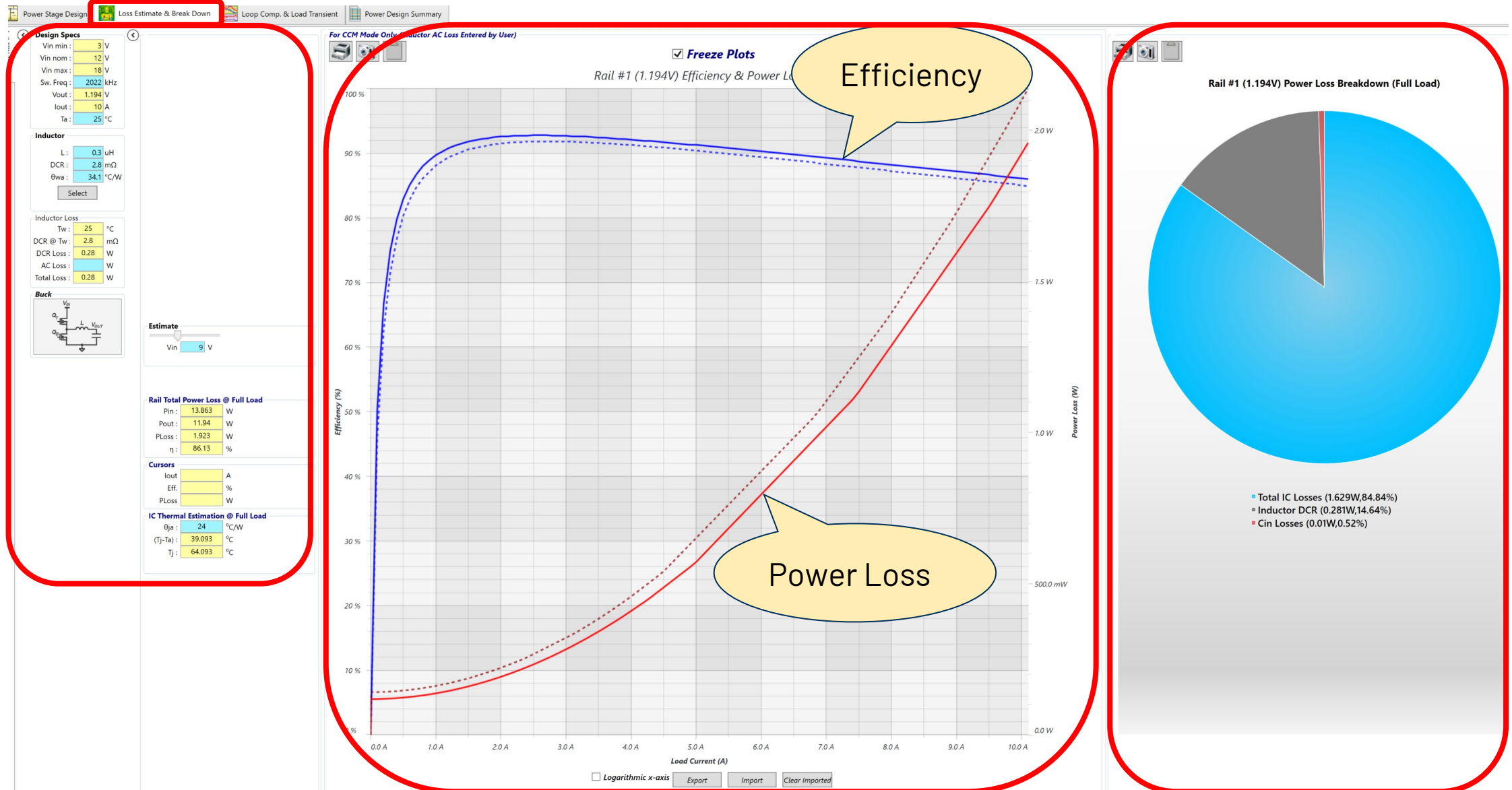

LTpowerCAD: Power Supply Design in 5 Easy Steps

LTM4638	Buck
LTM4640	Buck
LTC7151S	Buck
LTC7150S	Buck
LT8648S	Buck
LTC3613	Buck
LT7170-1	Buck
LT7170	Buck
LT8627SP	Buck
MAX8655	Buck

Product Selection

Schematic
(warnings, suggest)

Rail #1 (1.492V) Power Loss Breakdown (Full Load)

- Control Fet Conduction (0.479W,24.2%)
- Control Fet Turn On (0.056W,2.83%)
- Control Fet Turn Off (0.039W,1.97%)
- Control Fet Driving (0.013W,0.66%)
- Sync Fet Conduction (0.199W,10.06%)
- Sync Fet Driving (0.06W,3.03%)
- Sync Fet Body Diode (0.189W,9.55%)
- Inductor DCR (0.424W,21.42%)
- Inductor AC (0.2W,10.11%)
- Cap Losses (0.31W,15.68%)

Optimize Efficiency

Optimize Transient, Loop

LT8642S Supply Design Summary

Project Info:

Steady State:

Rail #	Vin Min.	Vin Nom.	Vin Max.	Fsw	Vo
1	10 V	12 V	15 V	300 kHz	0.9 V

Efficiency and Loop:

Rail #	Vo	Iomax	Eff.@Iomax	Ploss@Iomax	Loop
1	0.9 V	10 A	86.74 %	1.38 W	31.62

Recommendations and Warnings:

Power Components Bill Of Materials:

Ref. Des.	Value	Quantity	Description	Mfr. Name
U1		1	IC	LINEAR TECH
Lo1	0.52μH	1	IND	COILCRAFT
Cin1	22μF	1	CAP	WURTH
Coc1 Coc2	220μF	2	CAP	MURATA

Power Components Footprint:

Components: 5
Max Height: 3.2 mm

Design Summary

Free download @ www.analog.com/LTpowerCAD

LTpowerCAD Loop Comp & Load Transient Overview

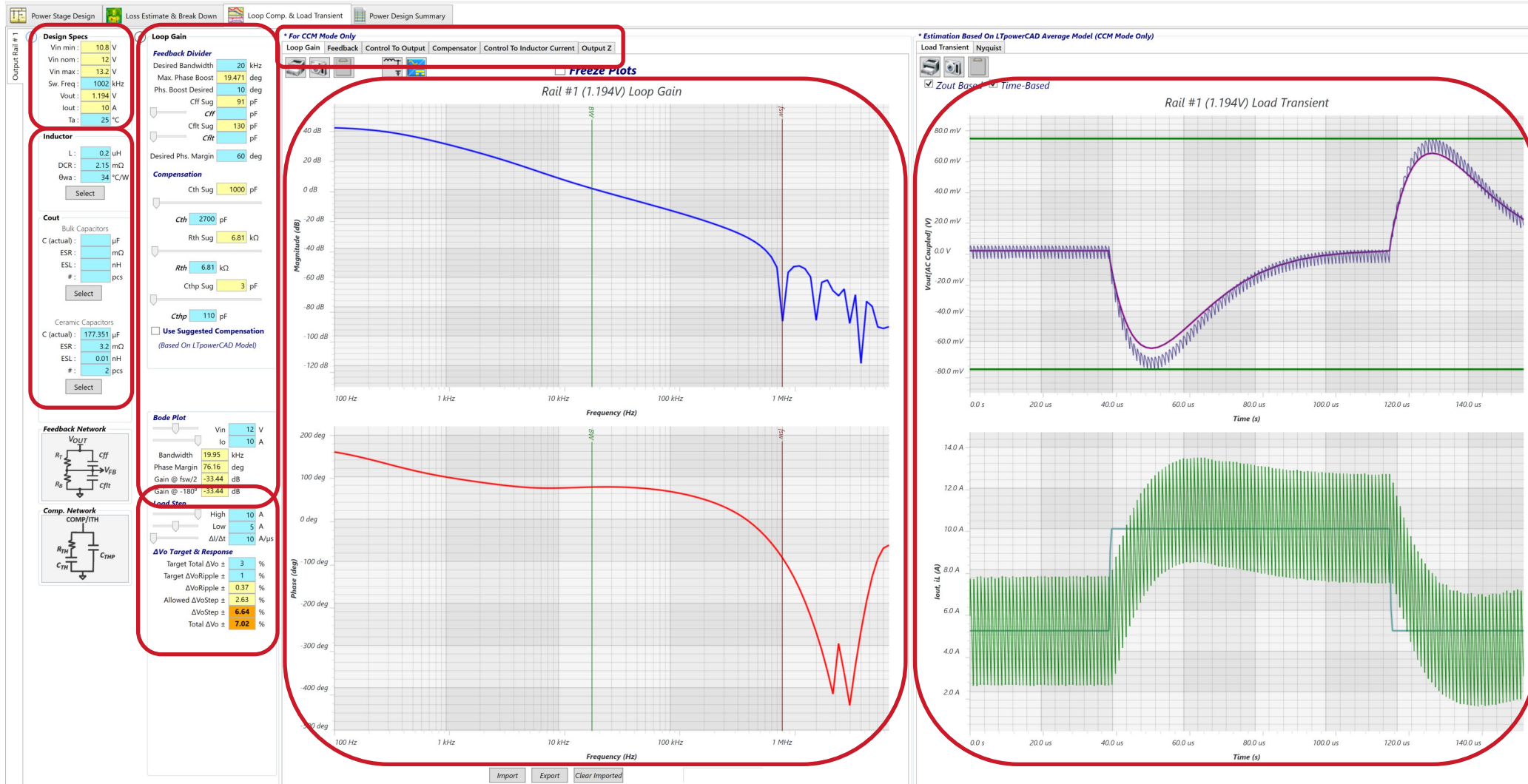

Loop Compensation (and Load Transient)

Loop gain: $T_V(s) = G_{CV}(s) \cdot K_{REF}(s) \cdot A(s)$

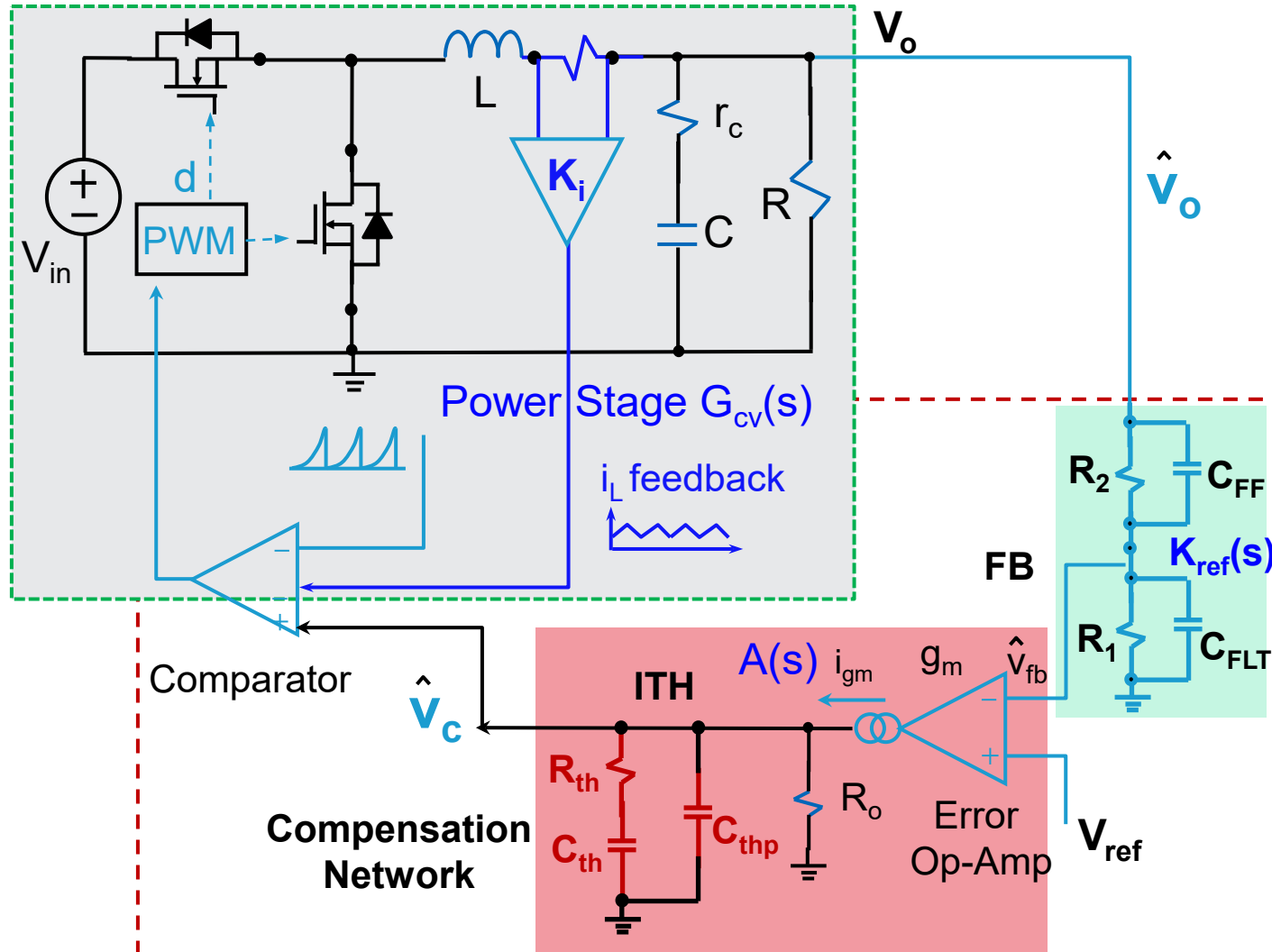

Buck Regulator: Design of Compensation Network

► High loop DC Gain (by default).

Target #1) Fast Transient Response. (High BW)

→ **Loop BW = 10%~ 20% f_{sw}**

Target #2) Stability. (across operating range)

→ **PM ≥ 45 degree. (≥ 60 degree preferred.)**

→ **GM ≤ -10 dB**

Target #3) Attenuate switching noises.

→ **Gain @ $f_{sw}/2 \leq -8$ dB.**

Target #4) Meet transient V_{pkpk} spec.

→ **$\Delta V_{OUT} < \pm 3\%$.**

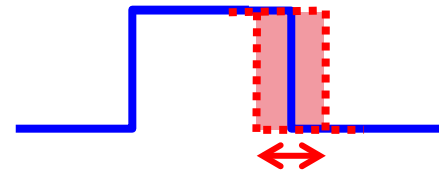

Component	Value	Units
R_{TH}	6.81	k Ω
C_{TH}	110	pF
C_{THP}	2700	pF
C_{FF}	none	pF

Initial values for LT8642S example
 $F_{sw} = 1$ MHz
Inductor = XEL4030-201MEB

Step 1: Set Loop Gain & Load Transient

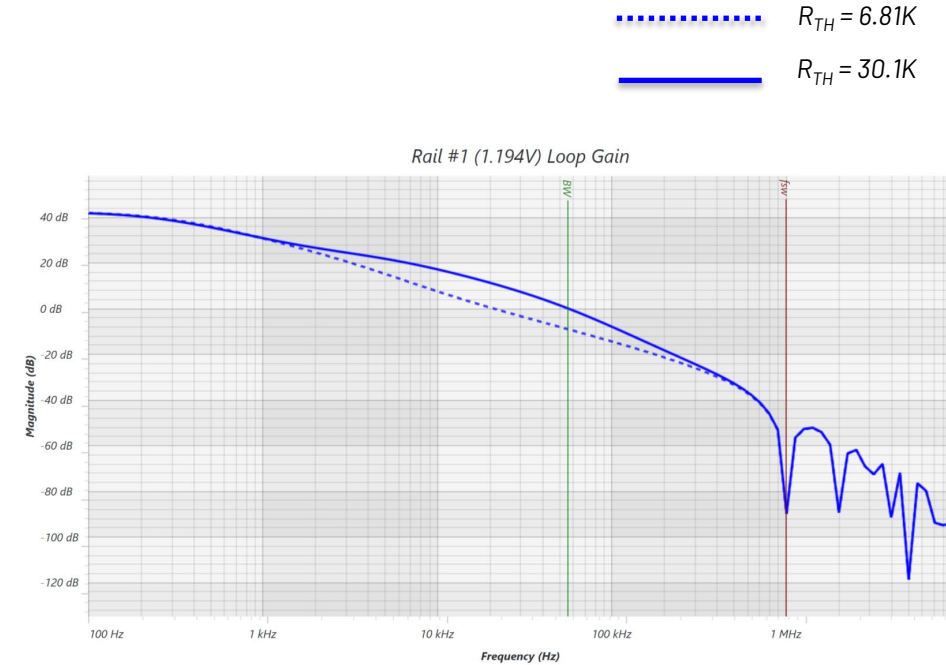
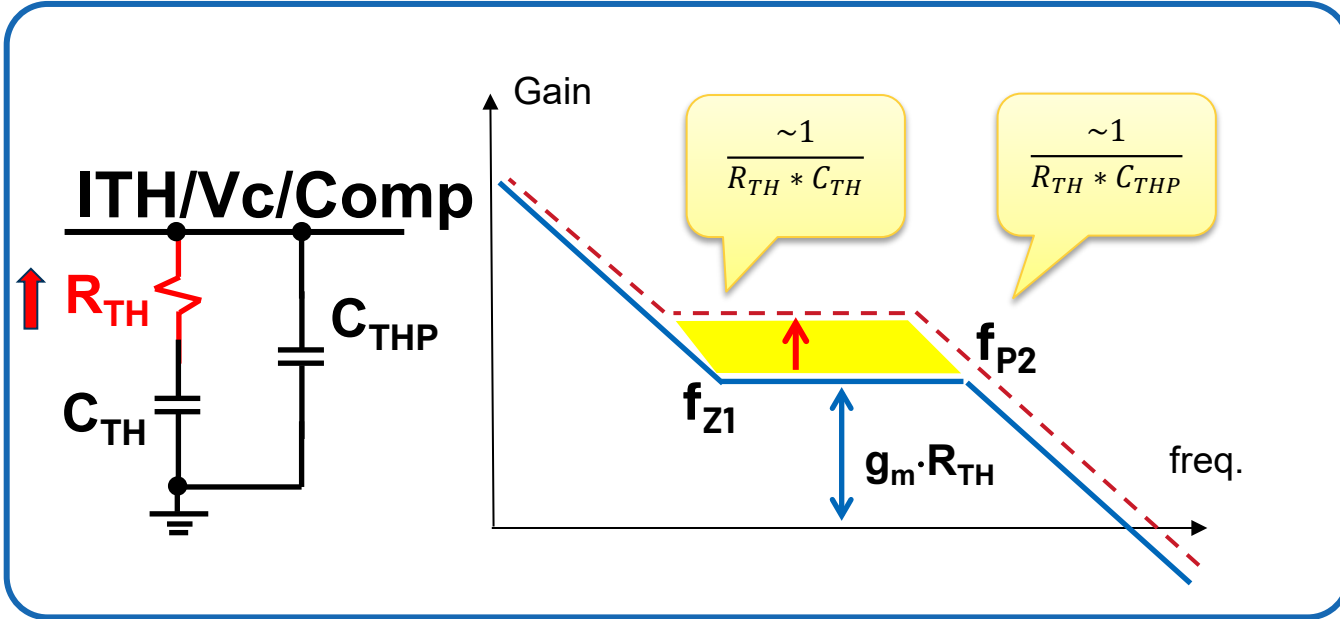

- Higher R_{TH} increases gain between f_{Z1} and f_{P2}
 - Reduces ΔV_{OUT} during load transients
 - Reduces phase margin at higher frequency

Step 1: Set Loop Gain & Load Transient

$R_{th} = 6.81K$ to $30.1K$
 $CTH = 2700pF$ and $CTHP = 110pF$

Stability Metric	$R_{TH} = 6.81k\Omega$	$R_{TH} = 10k\Omega$	$R_{TH} = 15k\Omega$	$R_{TH} = 20k\Omega$	$R_{TH} = 24.9k\Omega$	$R_{TH} = 30.1k\Omega$	$R_{TH} = 35.7k\Omega$	Effects of increasing R_{th}
Bandwidth (kHz)	19.95	28.18	39.81	50.12	50.12	56.23	56.23	Increases
Phase Margin (Deg)	76.16	78.57	71.5	61.22	56.53	48.7	44.8	Decreases Margin
Gain @ $f_{SW}/2$ (dB)	-33.46	-33.08	-32.88	-32.81	-32.78	-32.76	-32.74	Decreases Margin
Gain Margin (dB)	-33.46	-31.05	-28.91	-28.8	-26.92	-26.88	-26.86	Decreases Margin
ΔV_{OUT} (%)	7.01	5.86	4.88	4.46	4.28	4.18	4.14	Improves

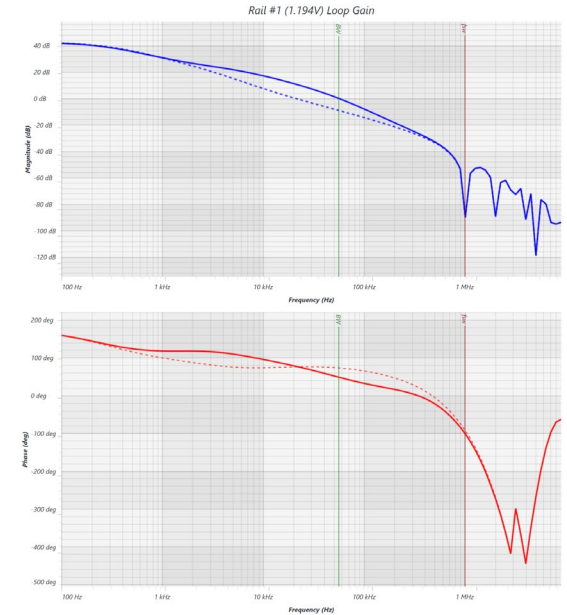

Zout Based Time-Based

$R_{th}=6.81K$ to $30.1K$

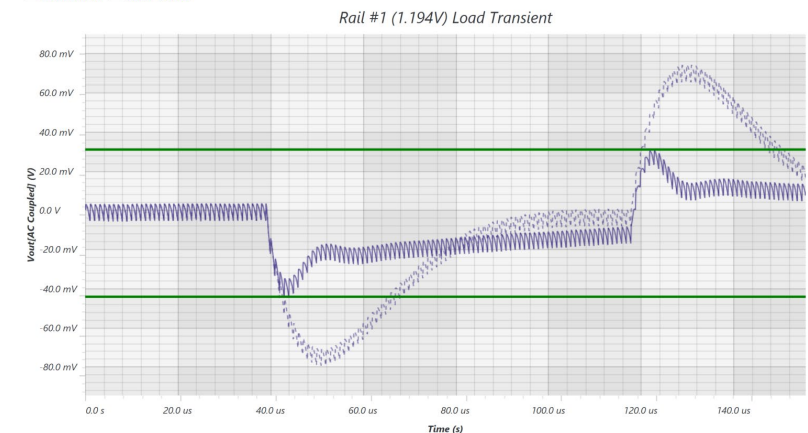

Loop BW = 10%~ 20% f_{SW}

$\Delta V_{OUT} < \pm 3\%$

PM $> 60^\circ$

GM $< -10dB$

Gain @ $f_{sw}/2 < -8dB$

Step 2: HF Gain Attenuation (C_{THP})

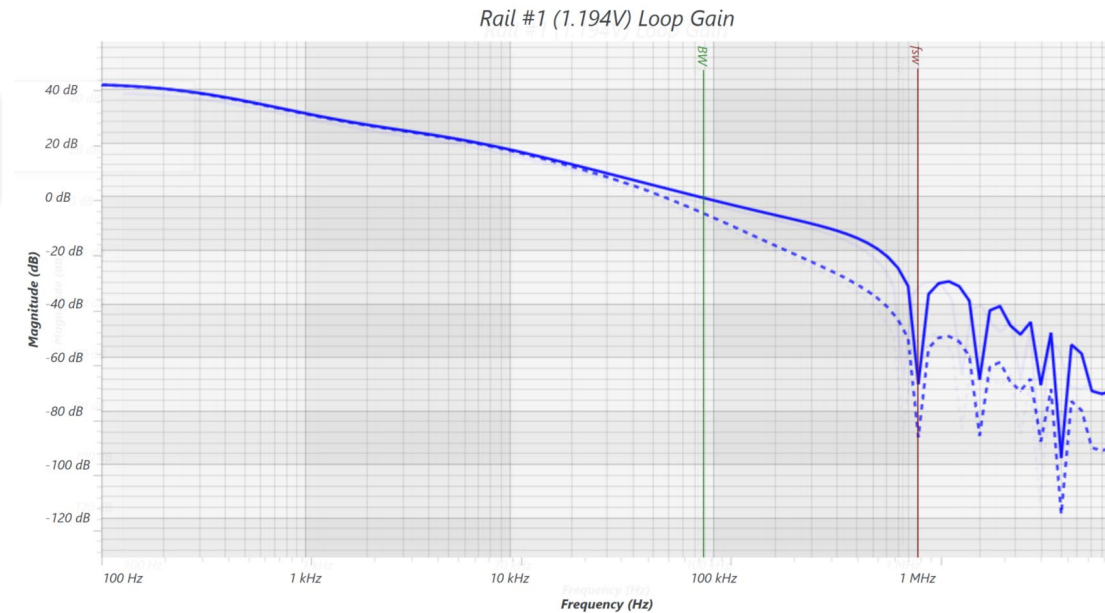
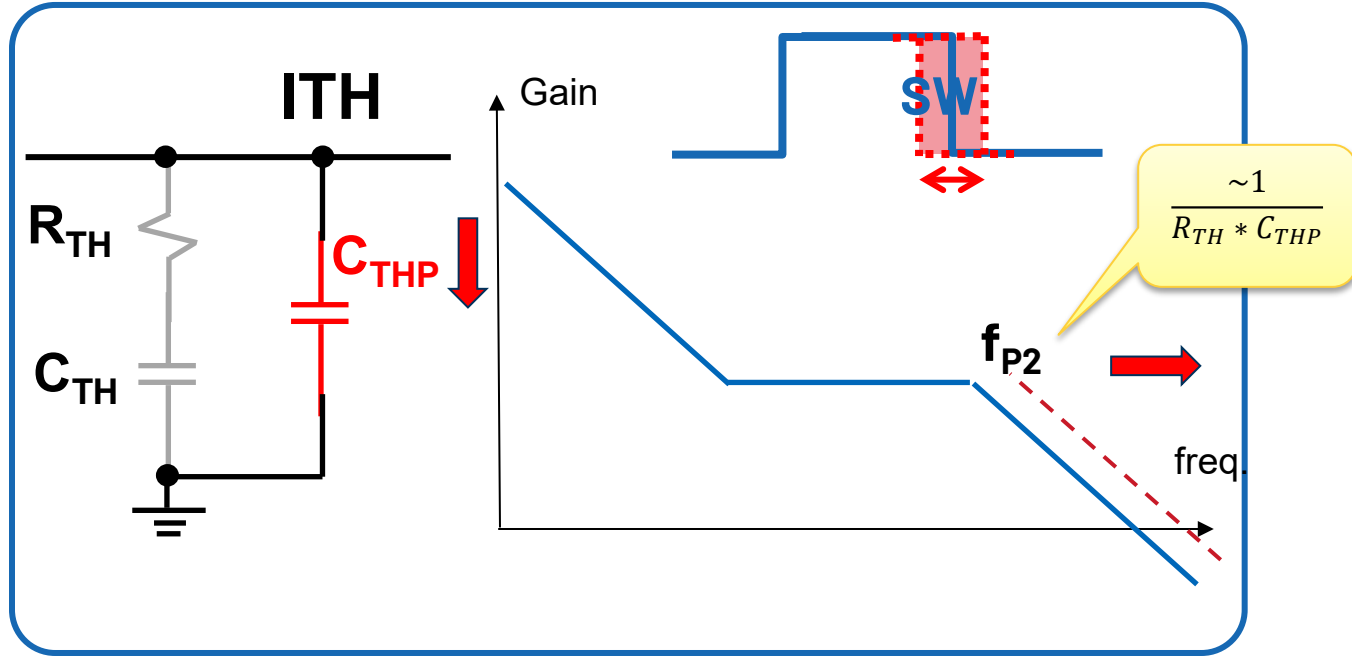

- Higher C_{THP} reduces HF gain, improve HF noise immunity
- Lower C_{THP} may increases transient ΔV_{OUT}
 - f_{P2} moves to a higher frequency and will affect PM and GM

Step 2: HF Gain Attenuation (C_{THP}) cont.

C_{THP} : 110pF to 4.7pF
 R_{TH} = 30.1K and C_{TH} = 2700pF

Stability Metric	C_{THP} = 110pF	C_{THP} = 100pF	C_{THP} = 47pF	C_{THP} = 22pF	C_{THP} = 10pF	C_{THP} = 4.7pF	Effects decreasing C_{THP}
Bandwidth (kHz)	56.3	56.23	70.79	79.43	79.43	89.13	Increases
Phase Margin (Deg)	48.7	51.22	63.3	74.64	82.87	85.69	Increases Margin at higher bandwidth
Gain @ $f_{SW}/2$ (dB)	-32.76	-31.98	-26.07	-20.99	-17.3	-15.42	Decreases Margin
Gain Margin (dB)	-26.88	-26.11	-24.01	-20.99	-19.31	-19.48	Decreases Margin
ΔV_{OUT} (%)	4.18	4.07	3.36	2.99	2.94	2.91	Improves

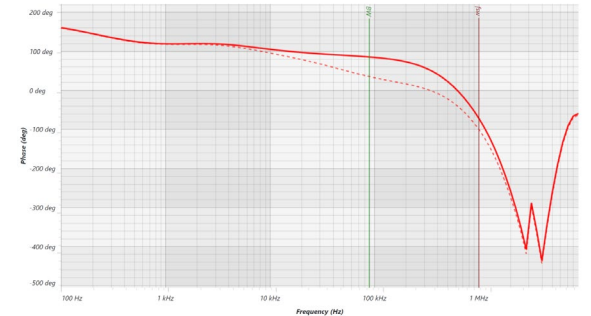
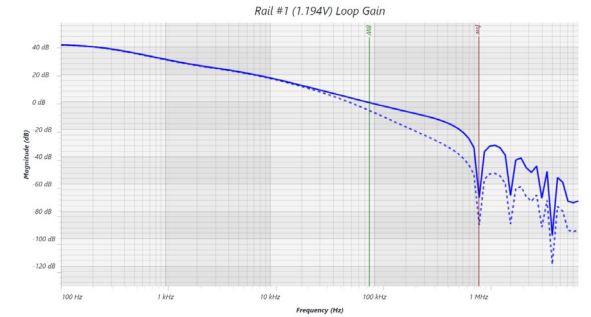

C_{THP} : 110pF to 4.7pF

Zout Based Time-Based

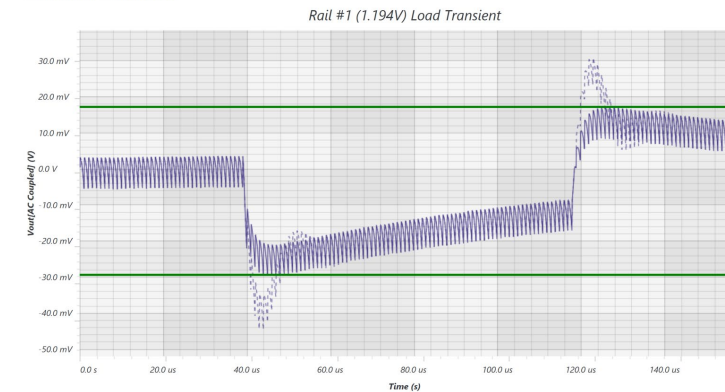

Loop BW = 10%~ 20% f_{SW}

✓ $\Delta V_{OUT} < \pm 3\%$

✓ $PM > 60^\circ$

✓ $GM < -10dB$

✓ Gain @ $f_{SW}/2 < -8dB$

Step 3: Adjust Settling Time

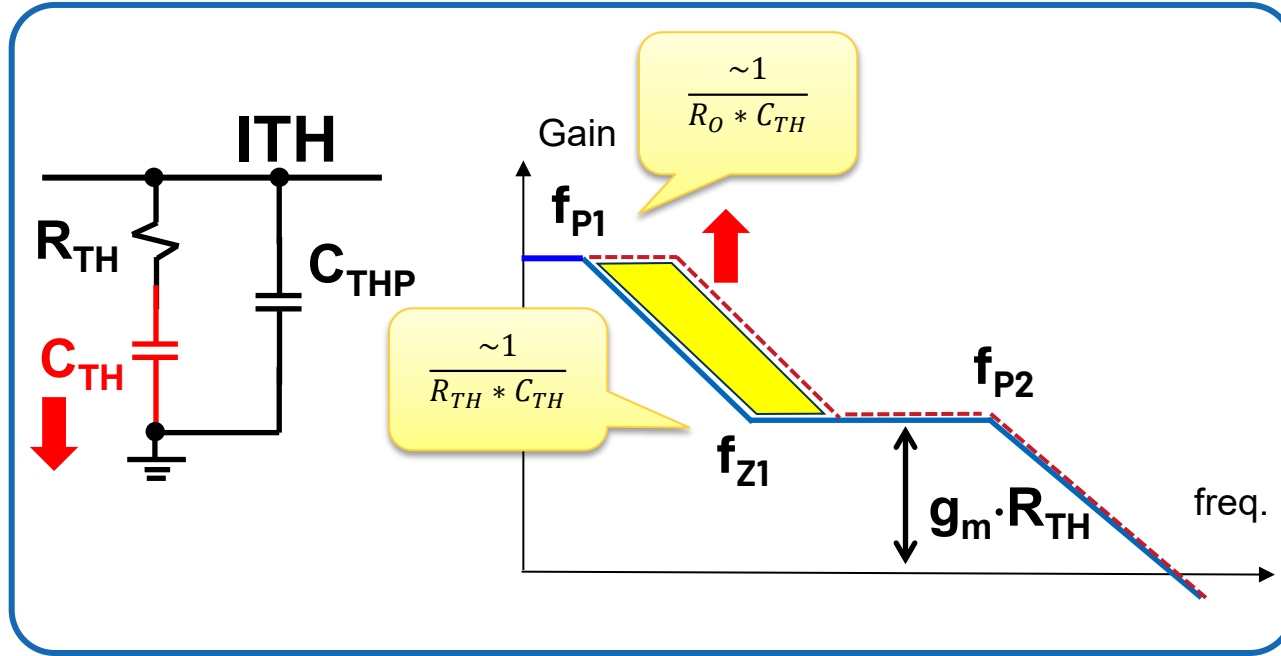

..... $C_{TH} = 2700\text{pF}$
 ——— $C_{TH} = 100\text{pF}$

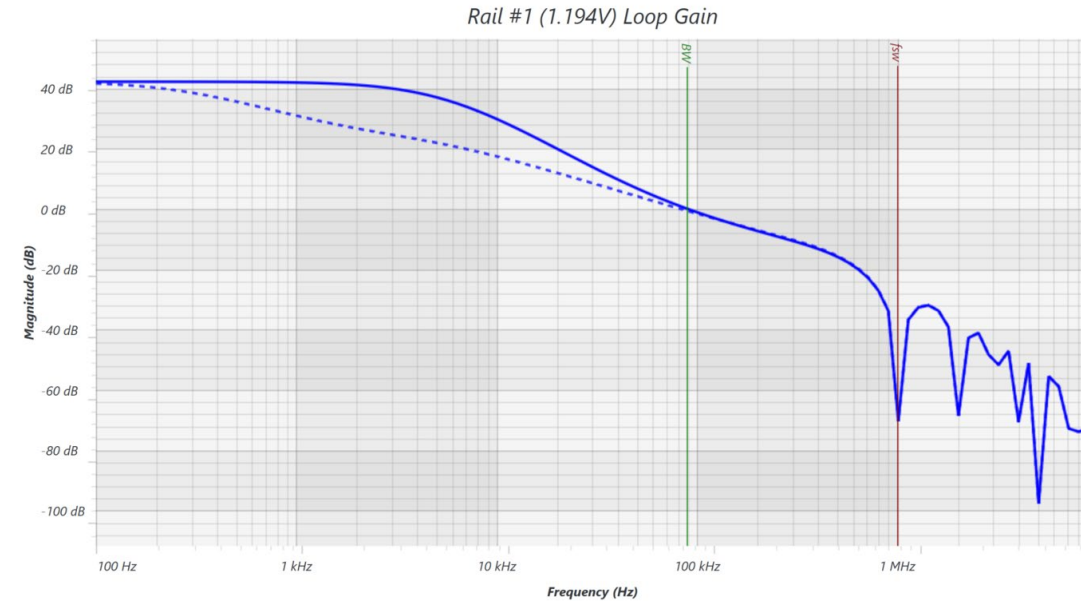

- Lower C_{TH} reduces settling time because of the High Gain in low frequency.
 - Potentially reducing Phase Margin if BW is around f_{Z1}

Step 3: Adjust Settling Time cont.

CTH: 2700pF to 100pF
 RTH = 30.1K and CTHP = 4.7pF

Stability Metric	CTH = 2700pF	CTH = 2200pF	CTH = 1500pF	CTH = 220pF	CTH = 100pF	Effects decreasing CTHP
Bandwidth (kHz)	89.13	89.13	89.13	89.13	89.13	No Effect
Phase Margin (Deg)	85.69	85.45	84.83	73.9	60.79	Decreases
Gain @ f _{SW} /2 (dB)	-15.42	-15.42	-15.43	-15.57	-15.75	Slight effect
Gain Margin (dB)	-19.48	-19.48	-19.49	-19.61	-19.76	Slight effect
ΔV _{OUT} (%)	2.91	2.85	2.81	2.49	2.33	Improves

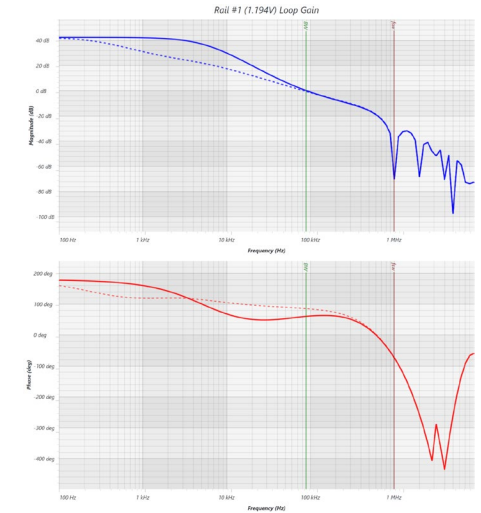

CTH: 2700pF to 100pF

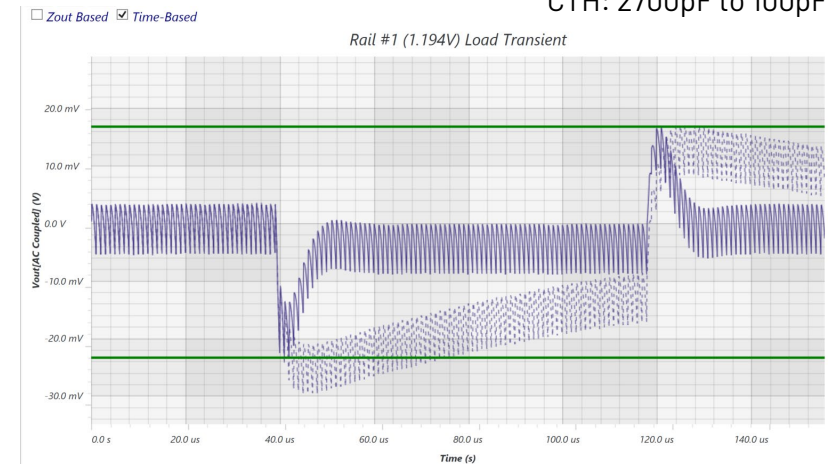

Loop BW = 10%~ 20% f_{SW}

✓ ΔV_{OUT} < ±3%

✓ PM > 60°

✓ GM < -10dB

✓ Gain @ f_{SW}/2 < -8dB

Step 4 Optimize the best you can

Repeat Step 1 – 3 in any order depending on what is needed.

- Need more phase in Low frequency? Increase CTH
- Need more phase in High Frequency? Decrease CTHP
- Need more Gain Margin? Increase CTHP or Decrease RTH
- Need more BW? Increase RTH or decrease CTHP
- **It is an iterative process**

□ Loop BW = 10%~ 20% f_{SW}

89.13KHz

*Bonus: Aim for the top of the “phase peak” in phase plot for more robust design.
Increase RTH from 30.1K to 45.3K

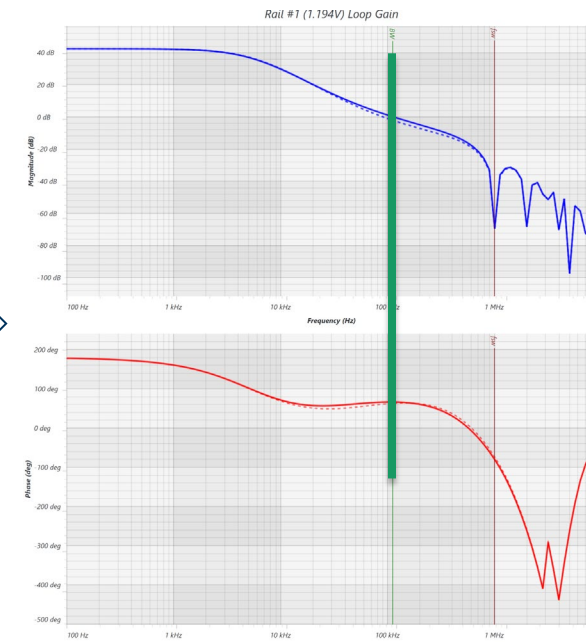
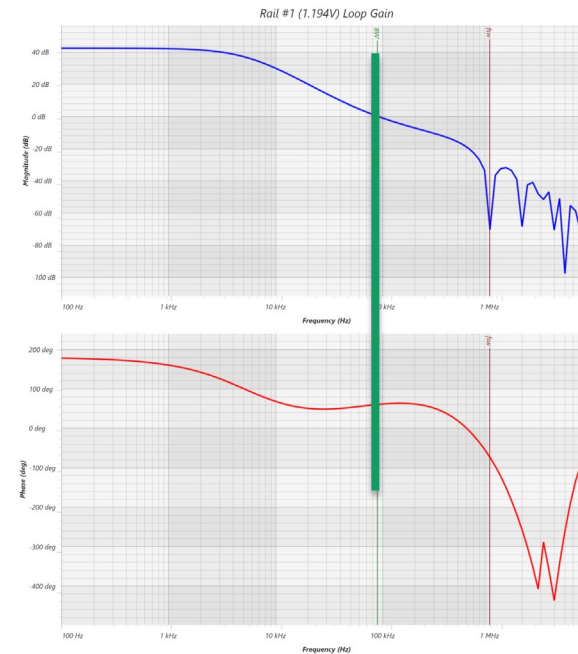

Final Step: Confirm Design Targets

Comp	Value
CTH	100pF
RTH	45.3K
CTHP	4.7pF

Compensation

Cth Sug 1000 pF

Cth 100 pF

Rth Sug 6.81 kΩ

Rth 45.3 kΩ

Cthp Sug 3 pF

Cthp 4.7 pF

Use Suggested Compensation
(Based On LTpowerCAD Model)

Bode Plot

Vin 13.2 V

Io 10 A

Bandwidth 112.2 kHz

Phase Margin 66.6 deg

Gain @ fsw/2 -14.1 dB

Gain @ -180° -16.05 dB

Load Step

High 10 A

Low 5 A

ΔI/Δt 10 A/μs

ΔVo Target & Response

Target Total ΔVo ± 3 %

Target ΔVoRipple ± 1 %

ΔVoRipple ± 0.37 %

Allowed ΔVoStep ± 2.63 %

ΔVoStep ± 1.86 %

Total ΔVo ± 2.23 %

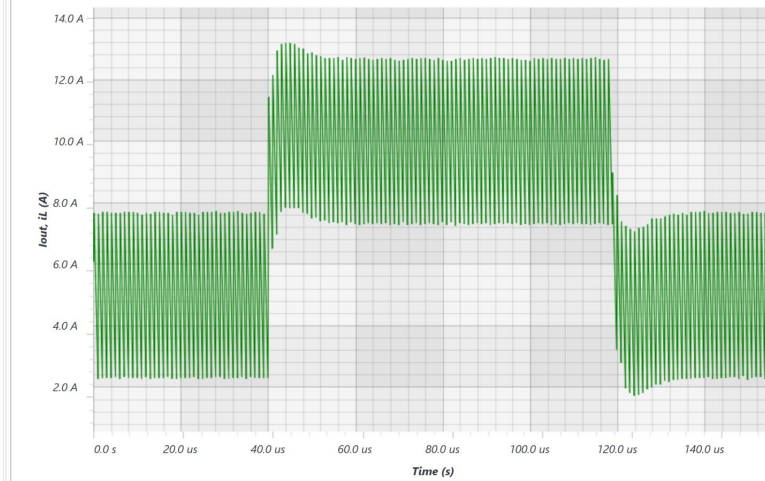
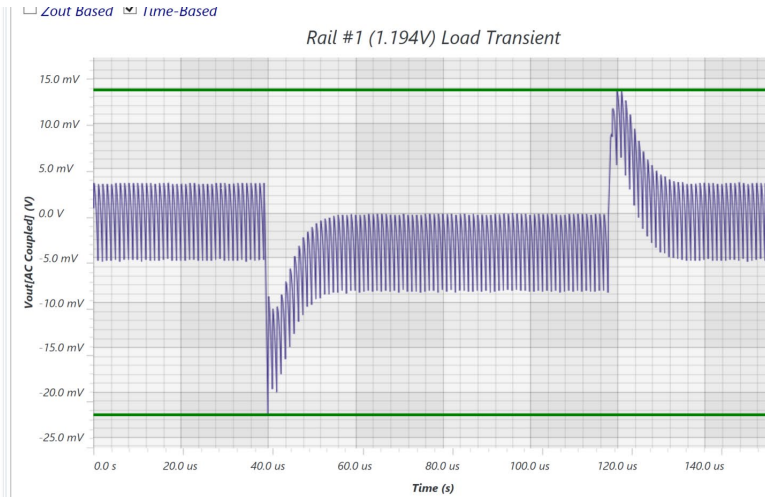
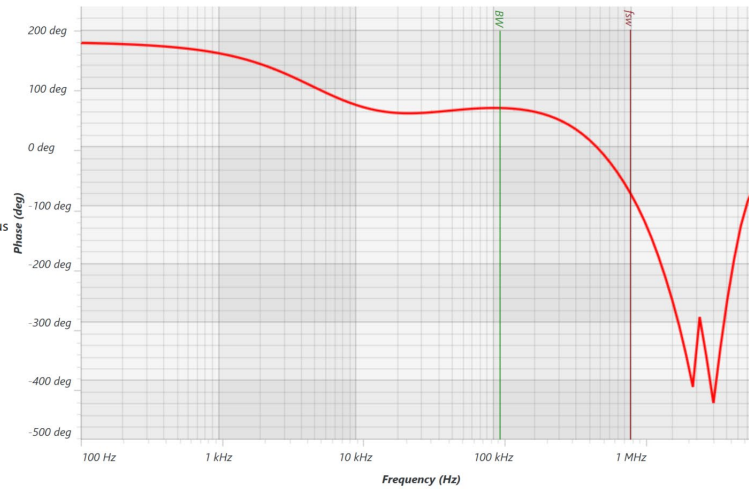
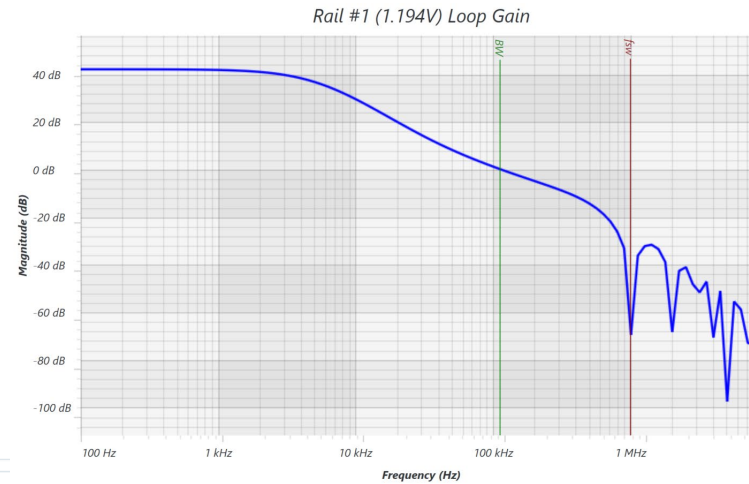

112KHz

✓ Loop BW ≤ 10%~ 20% f_{sw}

2.23%

✓ ΔV_{OUT} < ±3%

66.6°

✓ PM > 60°

-16.05dB

✓ GM < -10dB

-14.1dB

✓ Gain @ f_{sw}/2 < -8dB

Step A (Opt.): FB Capacitors

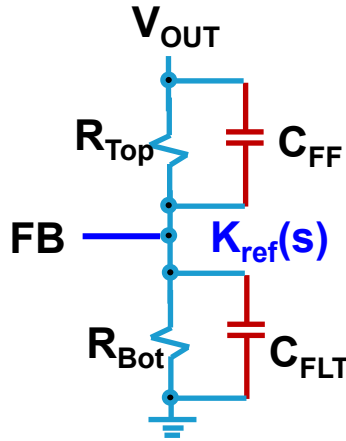

$$f_{Z-CFF} = \frac{1}{2 * \pi * (R_{TOP} * C_{FF})}$$

$$f_{P-CFF} = \frac{1}{2 * \pi * (R_{TOP} || R_{BOT}) * C_{FF}}$$

$$f_{P-CFILT} = \frac{1}{2 * \pi * (R_{TOP} || R_{BOT}) * C_{FILT}}$$

- Only add if necessary to provide additional BW and PM
 - Set phase boost peak f_{BST} around f_{BW}
 - Recommended: leave C_{ff} footprints on PCB

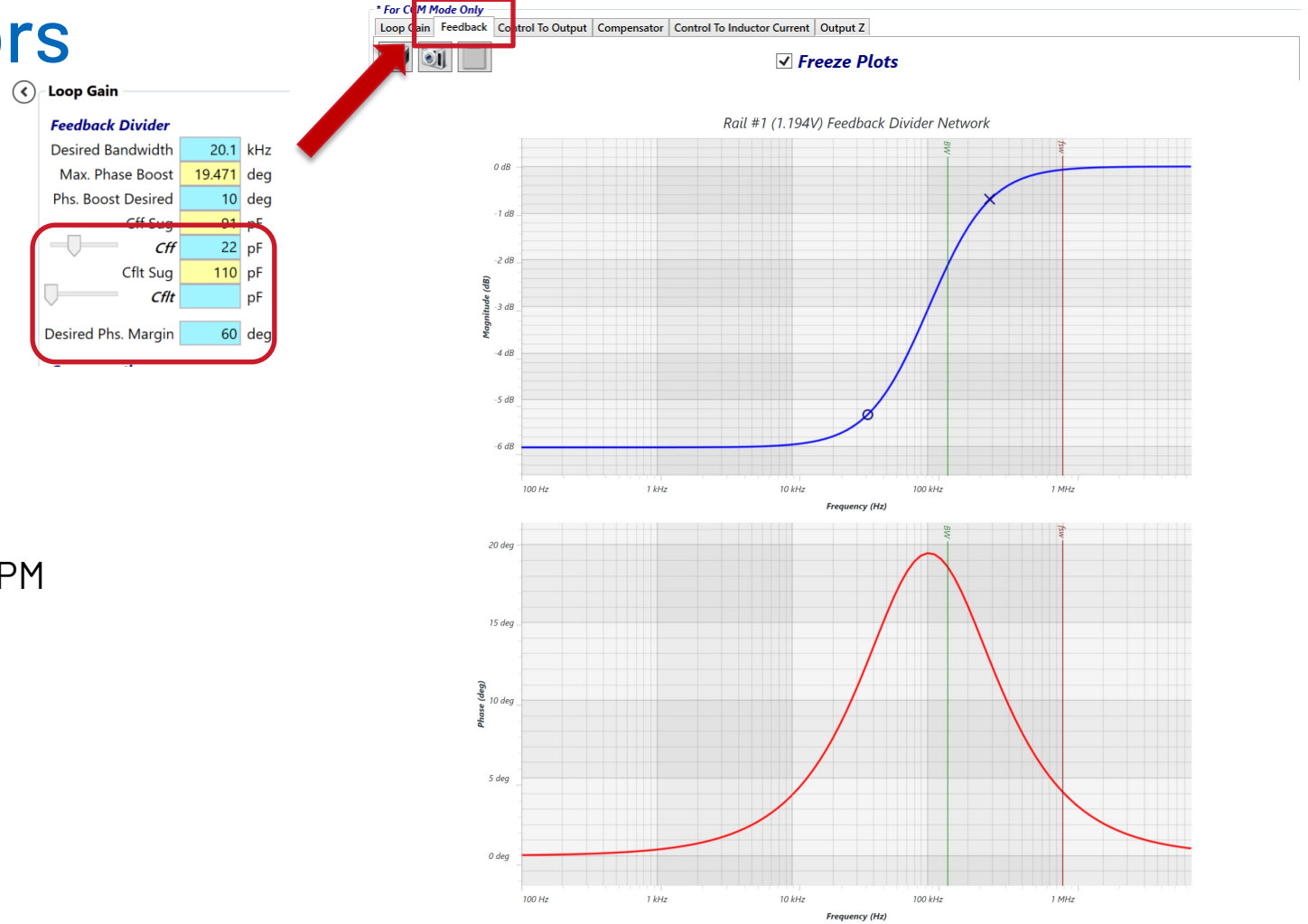

Feedback Loop

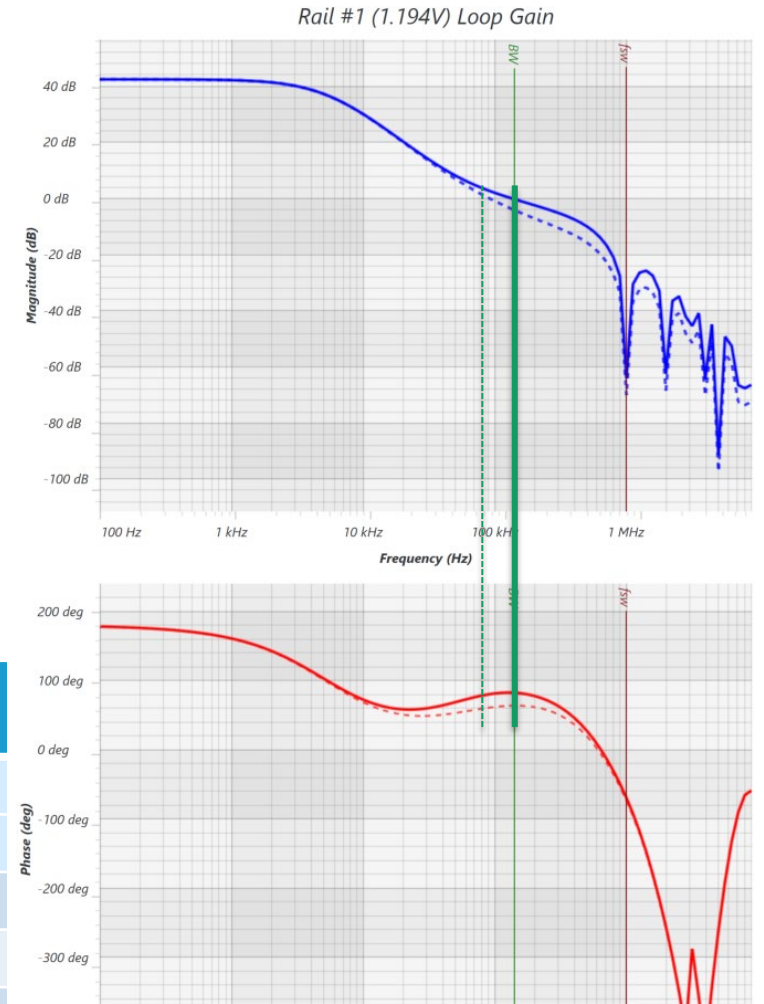
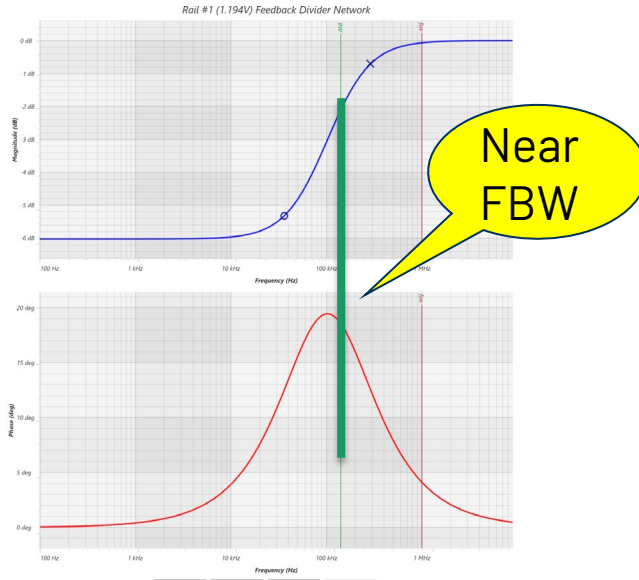
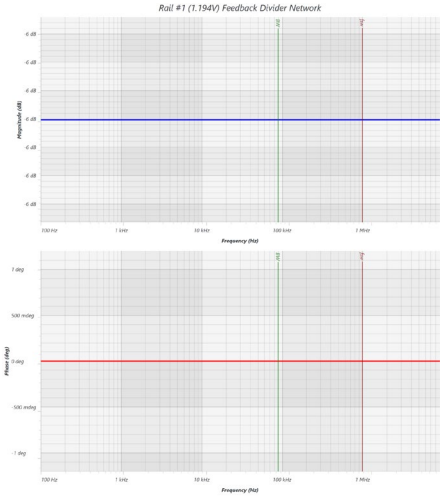

Stability Metric	CFF = OPEN	CFF = 22pF	Effects decreasing CTHP
Bandwidth (kHz)	89.13	141.25	Increases
Phase Margin (Deg)	60.79	82.4	Increases Margin
Gain @ f _{SW} /2 (dB)	-15.75	-9.98	Decreases Margin
Gain Margin (dB)	-19.76	-16.8	Decreases Margin
ΔV_{OUT} (%)	2.33	2.23	Improves

✓ Loop BW \leq 10%~ 20% f_{SW}

✓ $\Delta V_{OUT} < \pm 3\%$

✓ PM $> 60^\circ$

✓ GM < -10 dB

✓ Gain @ $f_{SW}/2 < -8$ dB

Summary of Compensation Design

1. Set Bandwidth and Transient Response
 1. Adjust RTH (higher RTH increases BW, decreases PM)
 2. Check for transient response target
2. Check for HF Attenuation
 - a) Adjust CTHP (higher CTHP improves noise immunity at the expense of BW)
3. Set Settling Time
 1. Adjust CTH (lower CTH reduces settling time at the expense of PM)
4. Optional: Feedforward Capacitor
 1. Check if phase boost is needed by looking at the PM and transient response
5. Close the loop
 1. Go back to Step 1 and re-check HF attenuation

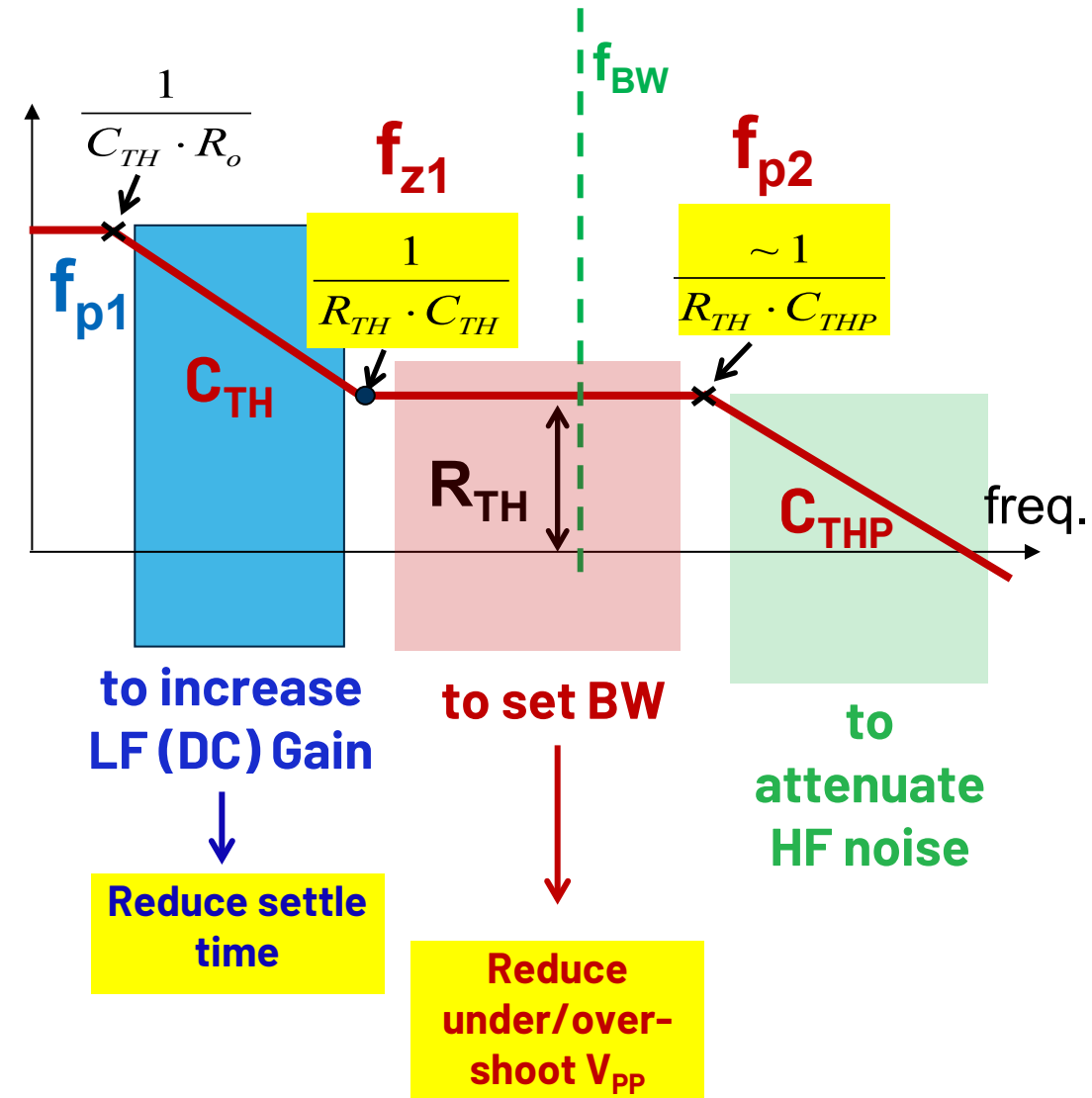

LTpowerCAD: Power Supply Design in 5 Easy Steps

LTM4638	Buck
LTM4640	Buck
LTC7151S	Buck
LTC7150S	Buck
LT8648S	Buck
LTC3613	Buck
LT7170-1	Buck
LT7170	Buck
LT8627SP	Buck
MAX8655	Buck

Product Selection

Schematic
(warnings, suggest)

Optimize Efficiency

Rail #1 (1.492V) Power Loss Breakdown (Full Load)

- Control Fet Conduction (0.479W, 24.2%)
- Control Fet Turn On (0.056W, 2.83%)
- Control Fet Turn Off (0.039W, 1.97%)
- Control Fet Driving (0.013W, 0.66%)
- Sync Fet Conduction (0.199W, 10.06%)
- Sync Fet Driving (0.06W, 3.03%)
- Sync Fet Body Diode (0.189W, 9.55%)
- Inductor DCR (0.424W, 21.42%)
- Inductor AC (0.2W, 10.11%)
- Cap Losses (0.31W, 15.68%)

Optimize Transient, Loop

Design Summary

LT8642S Supply Design Summary

Project Info:

Steady State:

Rail #	Vin Min.	Vin Nom.	Vin Max.	Fsw	Vo
1	10 V	12 V	15 V	300 kHz	0.9 V

Efficiency and Loop:

Rail #	Vo	Iomax	Eff.@Iomax	Ploss@Iomax	Loop
1	0.9 V	10 A	86.74 %	1.38 W	31.6

Recommendations and Warnings:

Message

Power Components Bill Of Materials: Export BOM

Ref. Des.	Value	Quantity	Description	Mfr. Name
U1		1	IC	LINEAR TE
Lo1	0.52μH	1	IND	COILCRAF
CinC1	22μF	1	CAP	WURTH
Coc1 Coc2	220μF	2	CAP	MURATA

Power Components Footprint:

Components: 5
Max Height: 3.2 mm
Component Clearance: 0.5 mm

Free download @ www.analog.com/LTpowerCAD

Design Summary

LT8642S Supply Design Summary

Project Info: LT8642S/DC2560, 3/2018



Design Specifications

Steady State :

Rail #	Vin Min.	Vin Nom.	Vin Max.	Fsw	Vo	ΔVo	ΔVo%	Io Max	ΔiLp-p	ΔiL%	iLpk	Duty	Ton min.	Toff min.
1	3 V	12 V	18 V	2022 kHz	1.19 V	4.35 mV	0.18 %	10 A	1.77 A	18 %	10.89 A	9.95 %	33 ns	298 ns

Efficiency and Loop :

Rail #	Vo	Iomax	Eff.@Iomax	PLoss@Iomax	Loop BW	Loop PM	Step Low	Step High	Step Slew	ΔVo@Step	ΔVo@Step %
1	1.19 V	10 A	85.05 %	2.1 W	79.43 kHz	67.03 deg	5 A	10 A	10 A/μs	24 mV	+/-2.01 %

Recommendations and Warnings :

Message

Power Components

Power Components Bill Of Materials :

[Export BOM](#)

Ref. Des.	Value	Quantity	Description	Mfr. Name	Mfr. Part #	Pkg. (Imperial)	L(mm)	W(mm)	H(mm)	User Note
U1		1	IC	LINEAR TECH	LT8642S		4	4	0.94	
Lo1	0.3μH	1	IND	COILCRAFT	XEL4030-301MEB		4.3	4.3	3.2	
Cinb1	22μF	1	CAP	MURATA	GRM32ER71E226KE15	1210	3.2	2.5	2.7	
Cinc1 Cinc2	10μF	2	CAP	MURATA	GRM188R61E106MA73	0603	1.6	0.8	1	
Coc1 Coc2	220μF	2	CAP	MURATA	GRM31CR60G227ME11	1206	3.2	1.6	1.9	

Power Components Footprint :

# Components	7	
Max. Height	3.2	mm
Component Clearance (d)	1.5	mm
* Power Components Area (Excludes ICs)	95.8	mm ²
	0.148	in ²
* Power Components Area (Includes ICs)	126.1	mm ²
	0.195	in ²

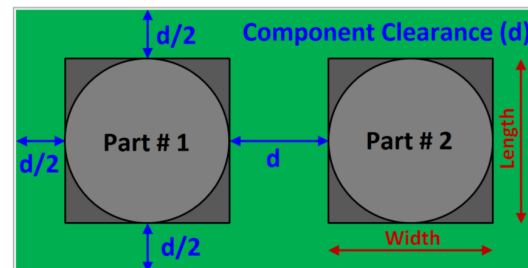

Questions ?













LTpowerCAD
More information

Toolbox



LTpowerCAD Design Toolbox

Copyright © 2021, Analog Devices Inc. All rights reserved.

Tool Name	Tool Description
 LTpowerCAD II Quick Start Guide	<i>User Guide for LTpowerCAD II</i>
 LTpowerPlanner III Quick Start Guide	<i>User Guide for LTpowerPlanner III New Features</i>
 LTpowerAnalyzer Quick Start Guide for LTpowerCAD	<i>Introduction Guide for LTpowerAnalyzer features for LTpowerCAD</i>
 LTpowerAnalyzer	<i>A Powerful Portable Power Supply Analyzer Lab Tool (by Bob Reay)</i>
 Ideal Diode MOSFET Calculator	<i>Ideal Diode Controller MOSFET Calculator for LTC435x & LTC437x</i>
 Resistor Divider	<i>Excel tool to select standard resistor values with minimum matching error</i>
 Copper R L Calculator	<i>Excel tool for calculating copper trace and via resistance and inductance</i>
 UV OV Hysteresis Calculator	<i>Calculator for Adding Hysteresis for Smooth Undervoltage and Overvoltage Lockout</i>
 LTM4650-2 AVP Calculator	<i>Active Voltage Positioning Calculator for LTM4650-2</i>
 LTC7106 Design Tool	<i>7-Bit Current DAC with PMBus Interface</i>
 Automotive Products List	<i>Automotive Products List (AECQ-100 Qualified)</i>
 Signal Chain Power Configurator Tool User Guide	<i>The SCP Configurator is an intuitive, easy to use software tool that allows nearly any sig evaluation. No power supply topology expertise necessary.</i>

Solutions Library



Project Name:
 Date:
 Designer:

LT8642S - 18V, 10A Synchronous Step-down Silent Switcher 2

Solutions Library ✖

Built-In Solutions

Part Name	Solution Name	Vin Min. (V)	Vin Nom. (V)	Vin Max. (V)	Output Voltages (V)	Output Currents (A)	Solution Description
LT8642S	Demo Board DC2560A	3	12	18	Vout1 = 1.2V	Iout1 = 10A	3-18Vin to 1.2V/10A, 2MHz

User's Solutions

Part Name	Solution Name	Vin [min] (V)	Vin [nom] (V)	Vin [max] (V)	Rail Voltage(s) (V)	Output Currents (A)	Description

Add This Project As A New Solution

New Solution Name : Bench Verified Designer Name :

New Solution Description : ADI Internal Only

Check C_{IN} and C_{OUT}

LT8642S - 18V, 10A Synchronous Step-down Silent Switcher 2

Date:
 Designer:

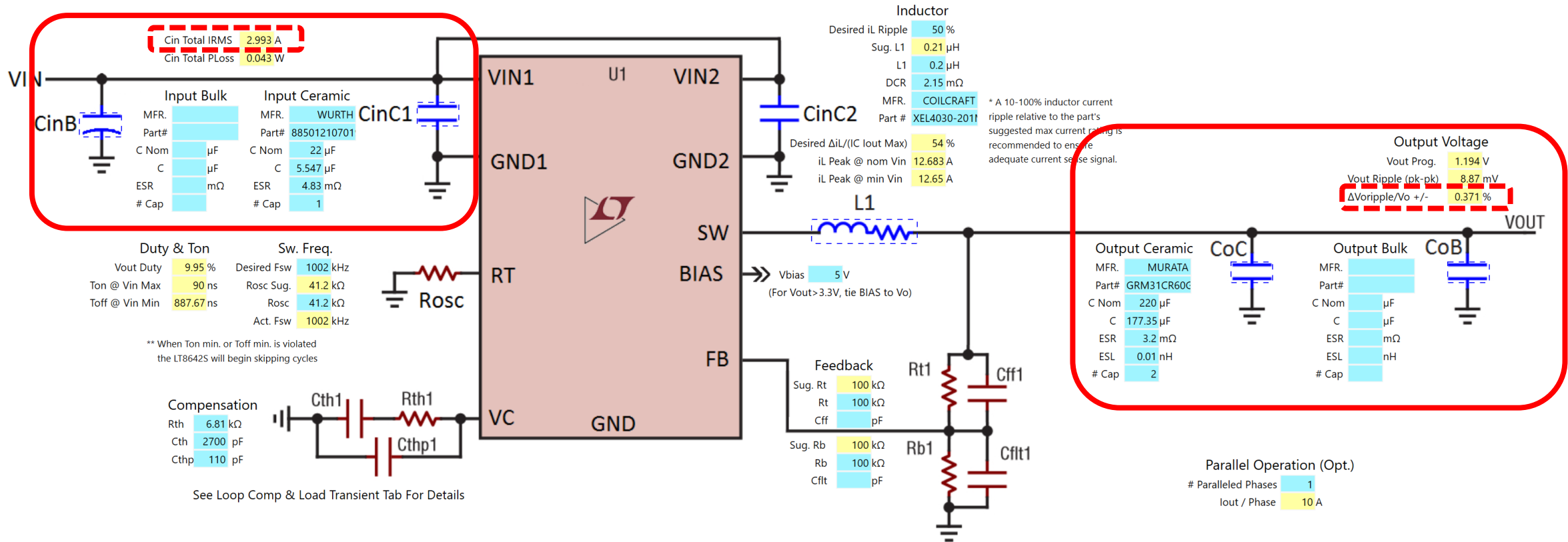

Capacitor Derating: Tips & Tricks

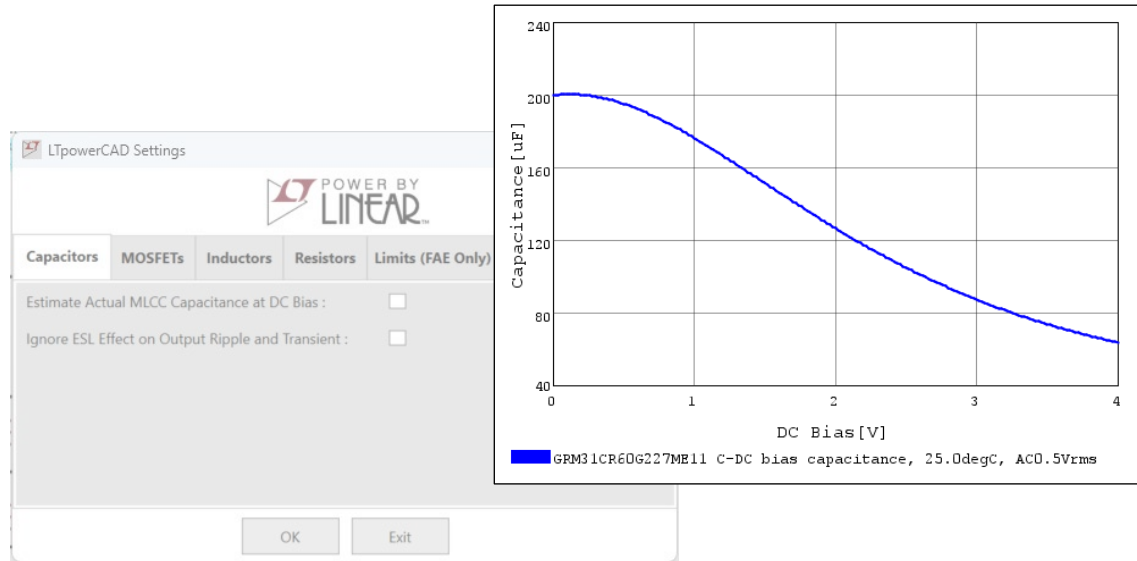

Part Number	C _{NOM} (uF)	LTpowerCAD Derating (uF)	C _{DC-BIAS} (uF)	C _{AC-BIAS} (uF)
GRM31CR60G227ME11	220	177.35	168.51	136.34
GRM21BD70J226ME44	22	21.125	20.65	16.58

*LTpowerCAD uses a 3-point interpolation and does not derate capacitance based on AC voltage or temperature

*LTpowerCAD only derates when selecting a capacitor from library.

Additional Information:

- Murata: [The voltage characteristics of electrostatic capacitance | Murata Manufacturing Articles](#)
- Kemet: [Here's What Makes MLCC Dielectrics Different](#)

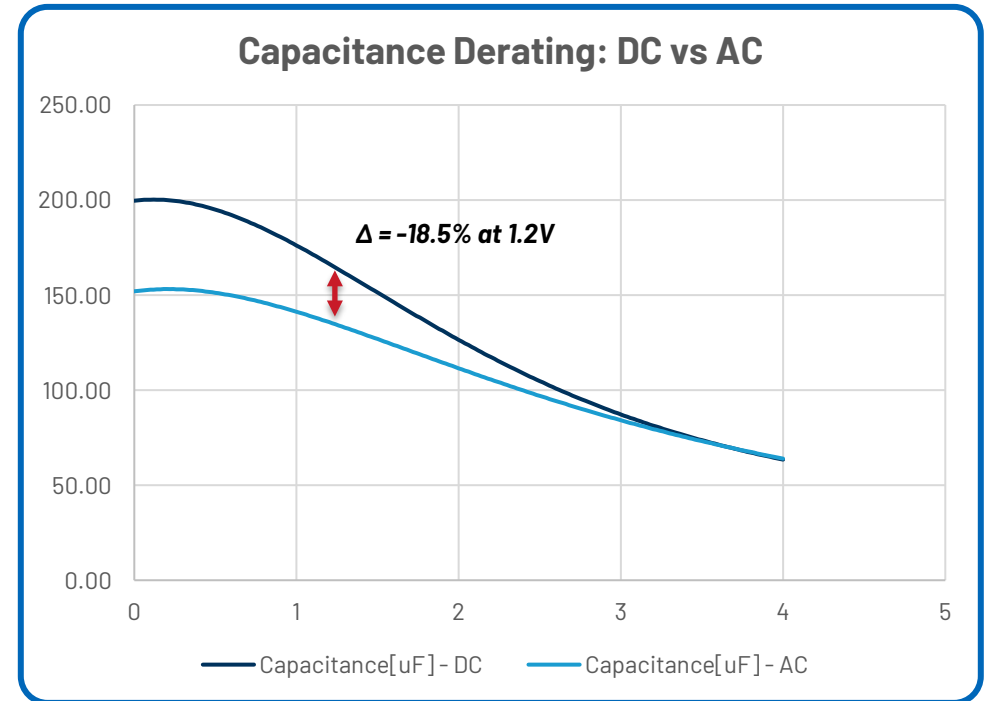

Performance characteristic curves obtained from Murata's [Simsurfing](#) Tool.