



ACCELERATING POWER SUPPLY DESIGN WITH WÜRTH ELEKTRONIK AND STMICROELECTRONICS

Manish Khandelwal

WÜRTH ELEKTRONIK MORE THAN YOU EXPECT

AGENDA

What We Will Cover Today

01

Introducing RedExpert

Who we are, what RedExpert is, and why it matters

03

RedExpert Platform Deep Dive

Live walk-through: features, AC/DC loss models, filters

05

Live Demo: Finding the Right Inductor

Step-by-step inductor selection using RedExpert

07

Rated Current Calculator

Custom Rated Current Measurement

02

Understanding Inductor Challenges in Power Design

Losses, thermal behaviour, saturation — the full picture

04

STEVAL-3601CV1 — The Design Challenge

DCP3601 EVM: specs, requirements, inductor role

06

Simulation Results & Comparison

AC losses, temperature rise, efficiency impact

08

Key Takeaways & Q&A

Summary, and open questions

REDEXPERT - THE WÜRTH ELEKTRONIK DESIGN PLATFORM

A free, browser-based simulation and selection tool built for power engineers.

Component Selection

Filter thousands of inductors, ferrite beads, and filter chokes by footprint, shielding type, inductance, DCR, and Isat.

World's Most Accurate AC Loss Model

Empirical lab data — not analytical equations — covering 10 kHz to 10 MHz across all core materials.

Thermal Simulation

Calculate temperature rise under real operating conditions. Visualise inductance vs. current curves at user-defined temperatures.

DC-DC Converter Design

Enter V_{in} , V_{out} , I_{out} , frequency, and ripple. RedExpert recommends the optimal inductance and ranks matching parts.

EMI Filter Designer

Design multi-stage EMI input filters. Simulate insertion loss with real component models.

Rated Current Calculator

Custom Rated current measurement

WHY INDUCTOR SELECTION IS CRITICAL IN POWER DESIGN

The inductor is often the most challenging component to select in a switching power supply. A poor choice leads to:

- Excessive heat and efficiency losses
- Core saturation causing instability
- Unexpected EMI / noise problems
- PCB space wasted on oversized parts
- Costly design re-spins and delays

Traditional datasheets only give DCR and Isat — they miss 65% of total losses!

Precise determination of inductor loss with REDEXPERT®

Navigate by order code

Enter at least first 4 characters

Design Tools	Product selection	Favorites
<ul style="list-style-type: none"> EMI Filter Designer Mag¹C Power Module Designer Resonance Tank Calculation for Wireless Power Filter Circuits DC/DC Converter Wireless Connectivity and Sensors Capacitor lifetime calculator Optoelectronics Power Magnetics 	<ul style="list-style-type: none"> EMC Components Power Inductors and Magnetics Mag¹C Power Products Signal & Communications Capacitors & Resistors Optoelectronics Quartz Crystals & Oscillators EMC Shielding & Grounding Thermal Management 	<ul style="list-style-type: none"> Multilayer Ceramic Chip Capacitors (MLCCs) Ferrites for PCB Assembly Power Inductors

Losses HIDE ALL

AC	DC	Total	ΔT_{tot}
75.2 mW	278 mW	353 mW	21.9 K

P vs. I_{out}

Explore AC + DC losses at light load

For all converters we provide detailed information of estimated losses and inductor self heating for the entire input voltage range, as well as varying output current, i.e. light load conditions.

LOSSES IN POWER INDUCTORS

Core Losses

- Hysteresis losses – magnetizing and demagnetizing
- Eddy Current losses – current generation in core

Copper Losses

- DC losses – depending of RDC
- AC losses – dependent of core, winding structure etc.

Design Goal

Reduce total losses and achieve high efficiency



WÜRTH ELEKTRONIK AC LOSS MODEL

CORE LOSS CALCULATION WITH STEINMETZ

Components

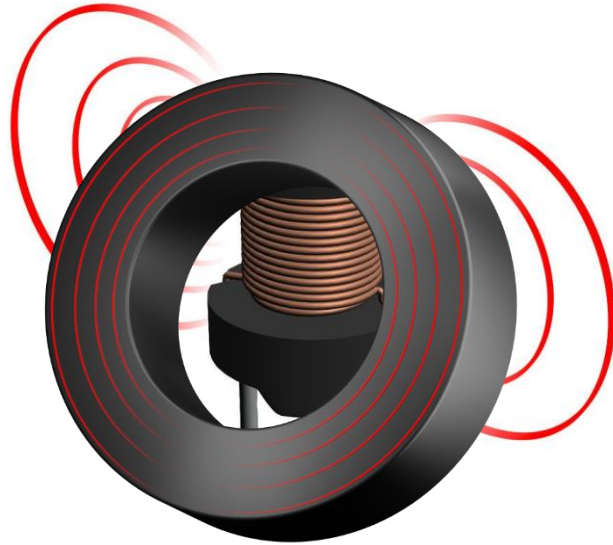

Real Components

Idealized

all materials

Ring cores

All core shapes

Air gap (fringing)

Winding structure

Method

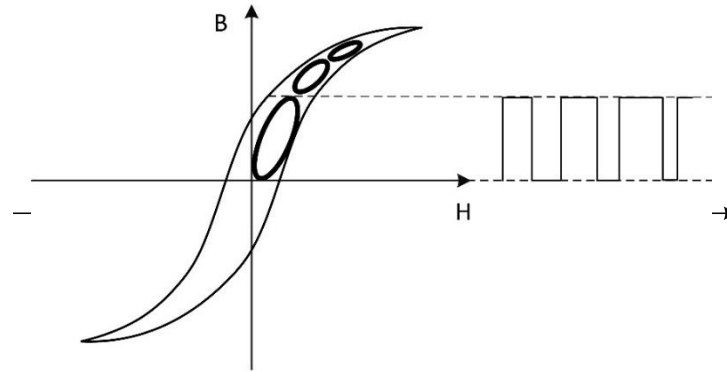

Point of Operation

Sinus signal

Square wave voltage

from with negative and

Triangular current

positive excitation

DC offset

Calculation

$$P_{AC} = f (\Delta I, \text{freq}, \text{DC}, k1, k2)$$

$$P_V = K \cdot f^\alpha \cdot \Delta B^\beta$$

$$P_V = K \cdot f^{\alpha-1} \cdot \Delta B^\beta \times f^r$$

$$P_V = K \cdot f_{eq}^\alpha \cdot \Delta B^\beta$$

Total AC Losses

Only core losses

AC core losses

+ AC copper losses

WÜRTH ELEKTRONIK AC LOSS MODEL

CORE LOSS CALCULATION WITH STEINMETZ

Components

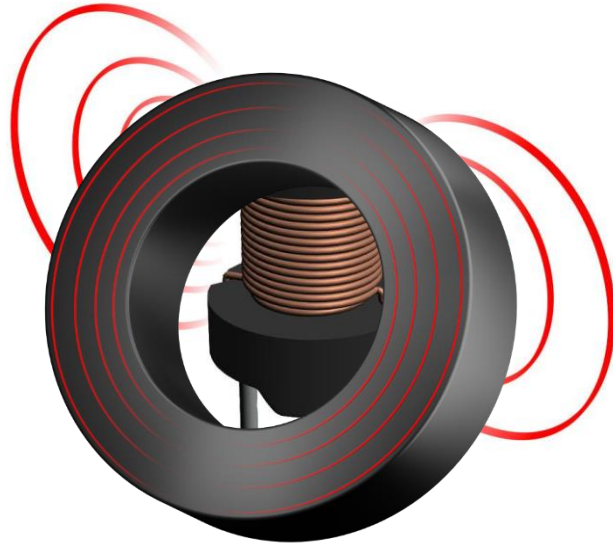

Real Components

Idealized

all materials

Ring cores

All core shapes

Air gap (fringing)

Winding structure

Method

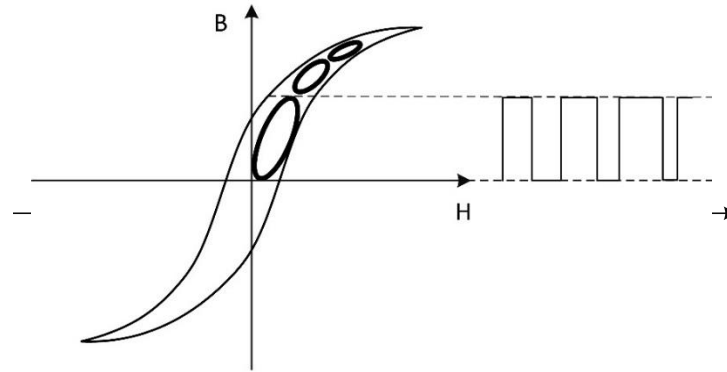

Point of Operation

Sinus signal

Square wave voltage

from with negative and

Triangular current

positive excitation

DC offset

Calculation

$$P_{AC} = K \cdot f^\alpha \cdot \Delta B^\beta$$

$$P_V = K \cdot DC \cdot k_1 \cdot \Delta B^\beta \cdot f^r$$

$$P_V = K \cdot f_{eq}^\alpha \cdot \Delta B^\beta$$

Total AC Losses

Only core losses

AC core losses

+ AC copper losses

ACCURACY

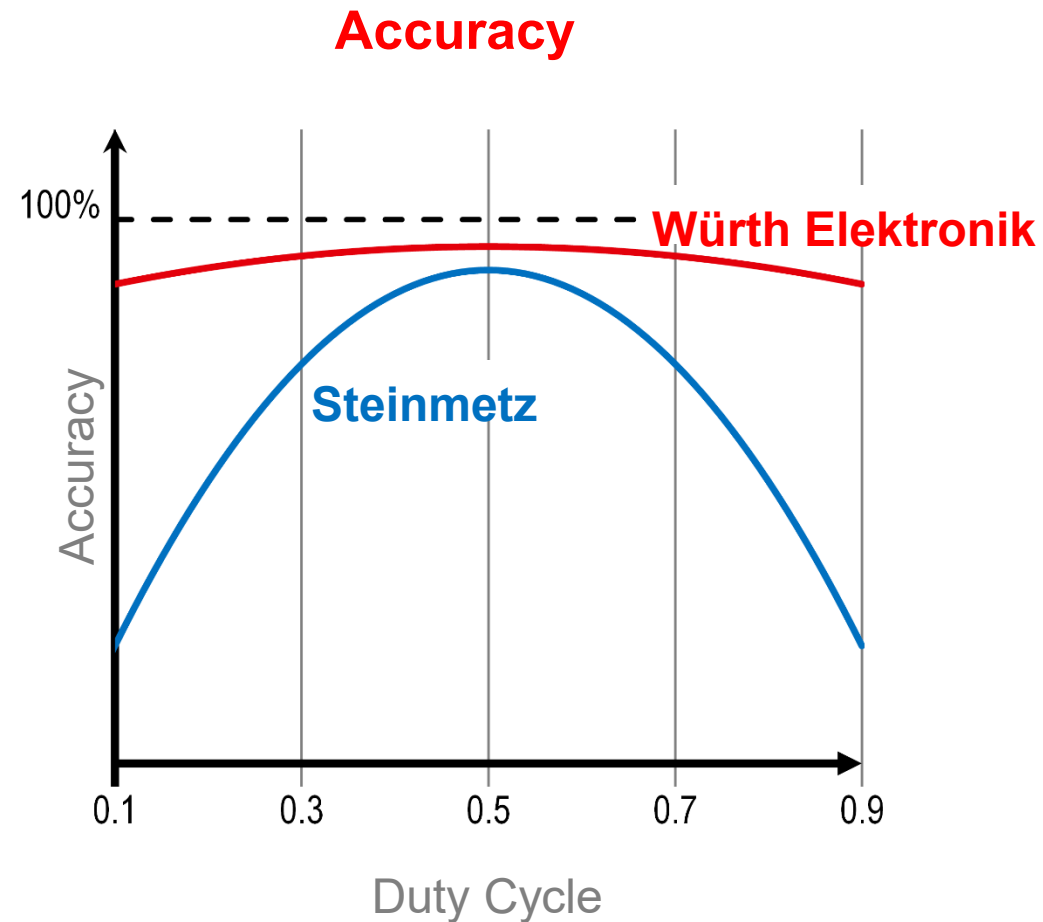

Validated for:

Frequency

- 10 kHz to 10 MHz

Duty Cycle

- 0.1 ... 0.9

AVAILABLE TOPOLOGIES

Buck Converter

PARAMETERS

Topology

Sync
 Non Sync

Input

$V_{in,min}$ 10 V $V_{in,max}$ 12 V

Output

V_{out} 5 V I_{out} 2 A

Switch

f_{sw} 500 kHz

Inductor

ΔL_L 40 % Show **Suitable**

Diode

V_f 0.7 V

UPDATE DETAILS

BUCK Non-Sync
& Sync

Boost Converter

PARAMETERS

Topology

Sync
 Non Sync

Input

$V_{in,min}$ 4 V $V_{in,max}$ 6 V

Output

V_{out} 12 V I_{out} 2 A

Switch

f_{sw} 500 kHz

Inductor

ΔL_L 40 % Show **Suitable**

Diode

V_f 0.3 V

UPDATE DETAILS

BOOST Non-Sync
& Sync

SEPIC Converter

PARAMETERS

Input

$V_{in,min}$ 4 V $V_{in,max}$ 6 V

Output

V_{out} 5 V I_{out} 1 A

Switch

f_{sw} 250 kHz

Inductor

type **Single** ΔL_{L1} 40 %
Show **Suitable** ΔL_{L2} 40 %

Diode

V_f 0.7 V

UPDATE DETAILS

SEPIC Single
& Coupled

Calculate Losses

PARAMETERS

Frequency Setup

f 800 kHz Duty cycle 0.4

Inductor

type **Single** Show **Suitable**

Winding 1

$I_{L,avg}$ 2 A ΔL_L 1 A

UPDATE DETAILS

Topology
independent
IL and VL

DESIGN CHALLENGE: STEVAL-3601CV1 EVM

ST STEVAL-3601CV1 Evaluation Board

Based on the DCP3601CMR miniaturised synchronous step-down (buck) converter.

This EVM demonstrates how a complete industrial power supply can be designed using just one IC, one inductor, two capacitors and two resistors.

Key Electrical Specifications

Input Voltage (Vin)	3.3 V – 36 V
Output Voltage (Vout)	5.0 V (fixed)
Output Current (Iout)	Up to 1 A
Switching Frequency	1 MHz (fixed)
Control Mode	Peak Current Mode
Quiescent Current	110 μ A (typical)
Efficiency (peak)	~91% at target load
EMI Compliance	CISPR 16-4-2

The Inductor's Role

- Energy storage between switch ON/OFF cycles
- Sets output ripple current magnitude
- Directly influences total system efficiency
- Impacts PCB footprint and cost
- Critical for EMI filter effectiveness
- Must handle wide Vin transients (up to 36 V)

Challenge: Select the optimal inductor for $V_{in}=24V \rightarrow V_{out}=5V @ 1A, 1MHz$ — then validate losses and thermal performance in RedExpert.

DESIGN CALCULATIONS

Calculating the Required Inductance — Before RedExpert

Determine the operating point and calculate the recommended inductance value.

Given: STEVAL-3601CV1 @ Vin = 24 V

Vin: 24 V (typical industrial bus)

Vout: 5.0 V

Iout(max): 1.0 A

fsw: 1 MHz

Ripple Δi_L : 30% of Iout = 0.3 A

Duty Cycle D: Vout/Vin = 5/24 \approx 0.208

Inductance Formula

$$L_{O(min)} = \frac{V_{IN} - V_{OUT}}{I_{OUT} \times \Delta i_L} \times \frac{V_{OUT}}{V_{IN} \times f_{sw}}$$

$$L = (24 - 5) \times 5 / (0.3 \times 24 \times 1,000,000)$$

$$L \approx 13.2 \mu\text{H}$$

Now, Enter these parameters into RedExpert

With all the input parameters, RedExpert will calculate the optimal value of inductance and show all the matching power inductors, and — critically — show you total AC + DC losses and temperature rise for every candidate part at this exact operating condition.

DESIGN CALCULATION

STEVAL-3601CV1 @ $V_{in} = 24\text{ V}$

$$L_{O(min)} = \frac{V_{IN} - V_{OUT}}{I_{OUT} \times \Delta i_L} \times \frac{V_{OUT}}{V_{IN} \times f_{sw}}$$

$$L_{O(min)} = \frac{24\text{ V} - 5\text{ V}}{1\text{ A} \times 0.3} \times \frac{5\text{ V}}{24\text{ V} \times 1\text{ MHz}}$$

$$L_{O(min)} = 13.2\ \mu\text{H}$$

Where does the difference come from?

Buck Converter

PARAMETERS

Input	Output	Switch	Inductor	Diode
24.0-24.0 V	5.00 V 1.00 A	1 MHz	30 %	700 mV

DETAILS

$I_{L,max,opt}$ 1.15 A	L_{opt} 14.6 μH	$I_{L,avg}$ 1.00 A
---------------------------	---------------------------------	-----------------------

74438356150

DC	ΔI_L	$I_{L,peak}$	T_{on}
0.23	313 mA	1.16 A	231 ns

Losses

AC	DC	Total	ΔT_{tot}
37.2 mW	200 mW	237 mW	10.7 K

DESIGN CALCULATION

The “correct” way to calculate

- Inductance Formula for Buck Converter (**REDEXPERT**)

$$L = \frac{V_{in} - V_{out}}{\Delta i_L * I_{out}} * \frac{V_{out} + V_D}{(V_{in} + V_D) * f_{sw}}$$

- After putting values in formula,

$$L = \frac{24 - 5}{0.3 * 1} * \frac{5 + 0.7}{(24 + 0.7) * 1000000}$$

$$L = 14.6 \mu\text{H}$$

- In many cases, the diode voltage can be neglected
- with $V_D \ll V_{out}$

$$L = \frac{V_{in} - V_{out}}{\Delta i_L * I_{out}} * \frac{V_{out}}{V_{in} * f_{switch}}$$

- **Suggestion:** The “perfect” inductance wont exist anyway, order a sample for one inductance value above and below your results

INDUCTOR SELECTION



REDEXPERT



Menu

Low entry access to electronics design with **REDEXPERT**

Navigate by order code

Enter at least first 4 characters

Design Tools

- EMI Filter Designer
- Mag¹C Power Module Designer
- Resonance Tank Calculation for Wireless Power
- Filter Circuits >
- DC/DC Converter >
- Wireless Connectivity and Sensors >
- Capacitor lifetime calculator >
- Optoelectronics >
- Power Magnetics >

Product selection

- EMC Components >
- Power Inductors and Magnetics >
- Mag¹C Power Products
- Signal & Communications >
- Capacitors & Resistors >
- Optoelectronics >
- Quartz Crystals & Oscillators >
- EMC Shielding & Grounding >
- Thermal Management >

Favorites

- Multilayer Ceramic Chip Capacitors (MLCCs)
- Ferrites for PCB Assembly
- Power Inductors

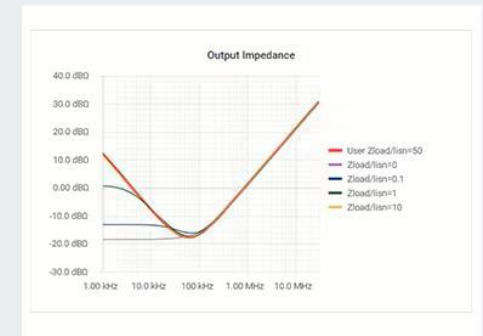

Filter Designer shows the output impedance for many load impedances

Our EMI Filter Designer shows the output impedance for a variety of different load / LISN impedances from 0 up to 10 Ohms.



TOTAL LOSSES

Buck Converter			
PARAMETERS			
Input	Output	Switch	Inductor
24.0-24.0 V	5.00 V 1.00 A	1 MHz	30 %
DETAILS			
$I_{L,max,opt}$	L_{opt}	$I_{L,avg}$	
1.15 A	13.2 μ H	1.00 A	
744393465150			
DC	ΔI_L	$I_{L,peak}$	T_{on}
0.21	266 mA	1.13 A	208 ns

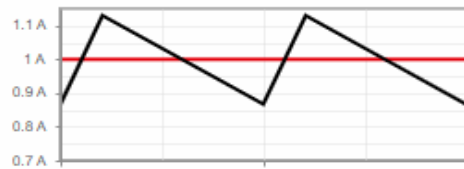

Losses			
AC	DC	Total	ΔT_{tot}
12.4 mW	28.6 mW	41.0 mW	326 mK

Losses			
AC	DC	Total	ΔT_{tot}
12.4 mW	28.6 mW	41.0 mW	326 mK

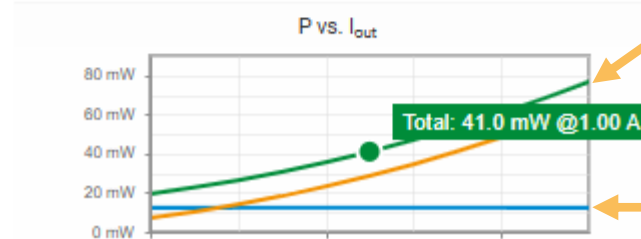
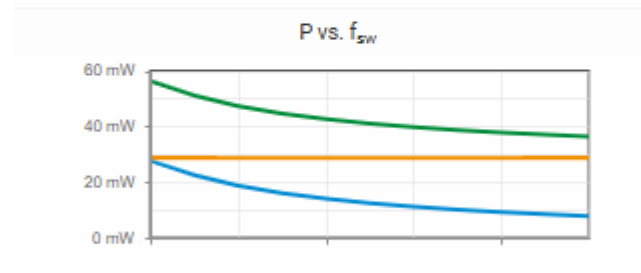
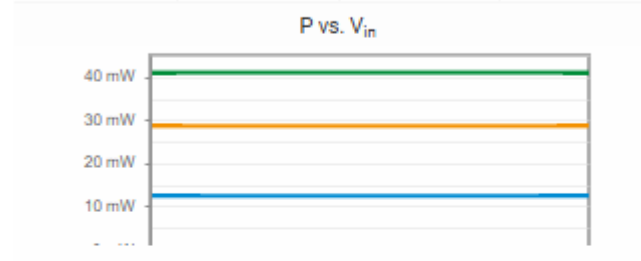
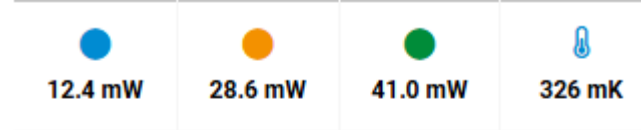

Good overview for low and high load losses

AC losses stay the same in CCM

<https://redexpert.we-online.com/re/5y5b3yc4>

SATURATION

Beware the Saturation!

- RedExpert will rely on the rated inductance to calculate the ripple
- Inductance roll-off by saturation is not (yet) included in the automatic calculation
- Saturation Roll_off is not standardized and can vary 10...35% percent between different Series
- Using the Slider, you can verify the actual inductance under operating conditions

<https://www.we-online.com/re/5eYI59KPluS>

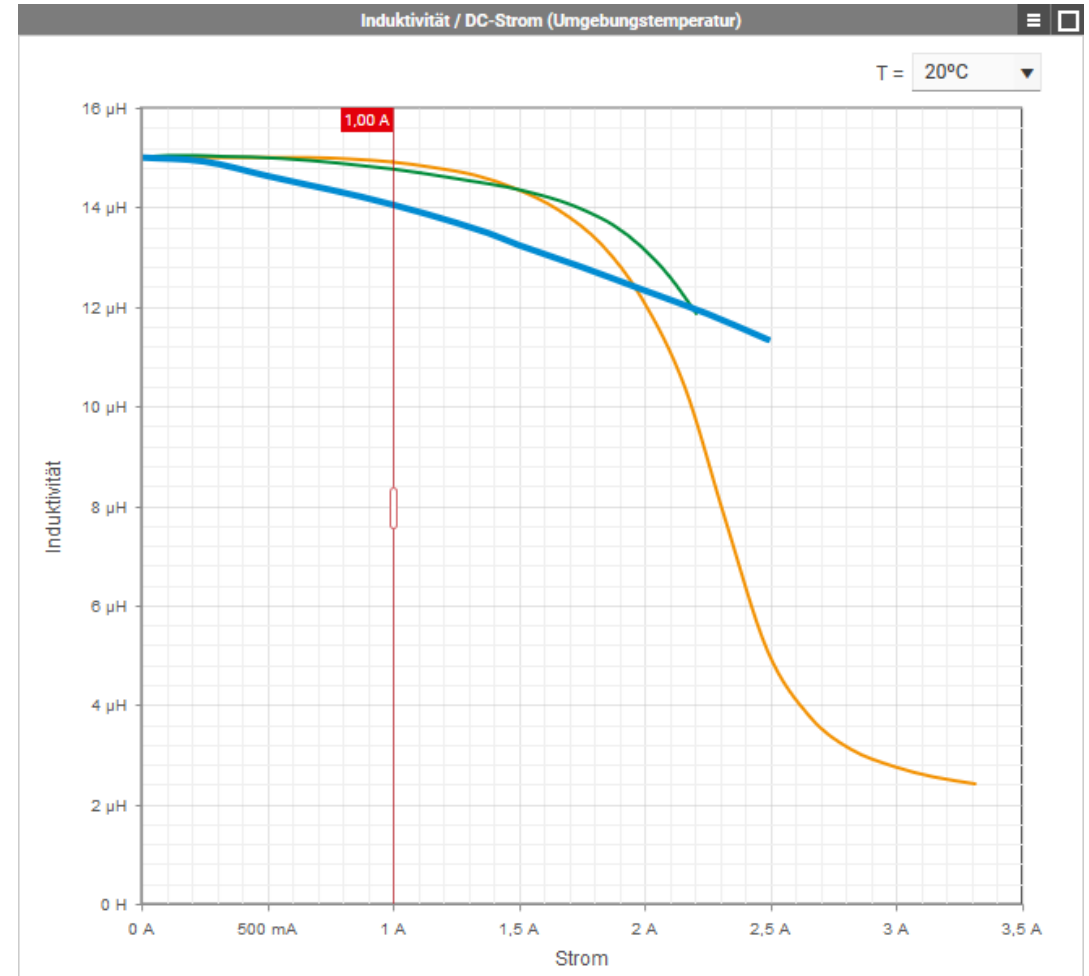

SATURATION

Saturation vs. Temperature

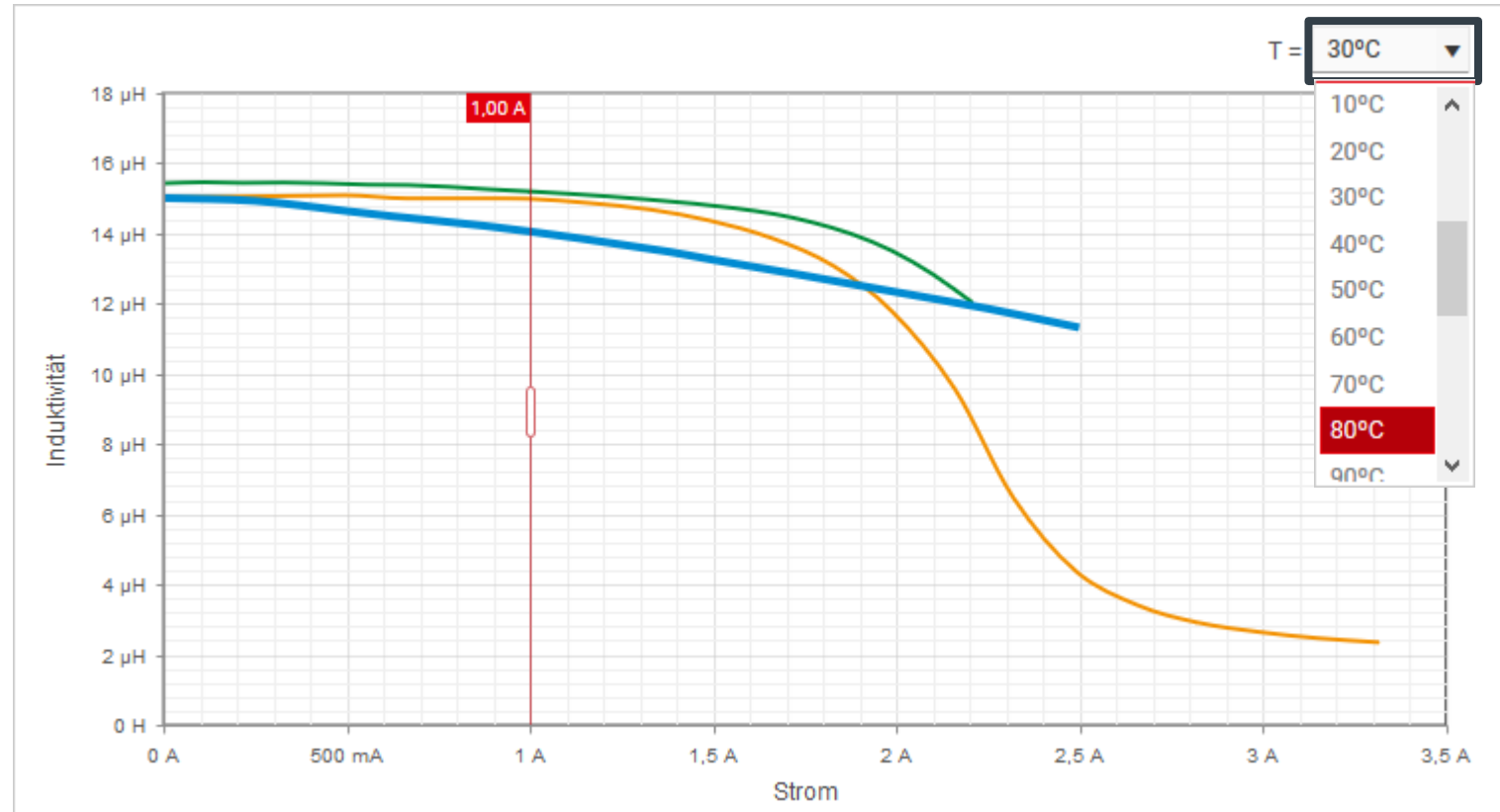

RATED CURRENT CALCULATOR

- Würth Elektronik has developed a thermal model which calculates the rated current of power inductors given specific trace dimension on a PCB.
- This will give design and component engineers the ability to explore how the rated current of parts is affected by different conductor dimensions used on the PCB

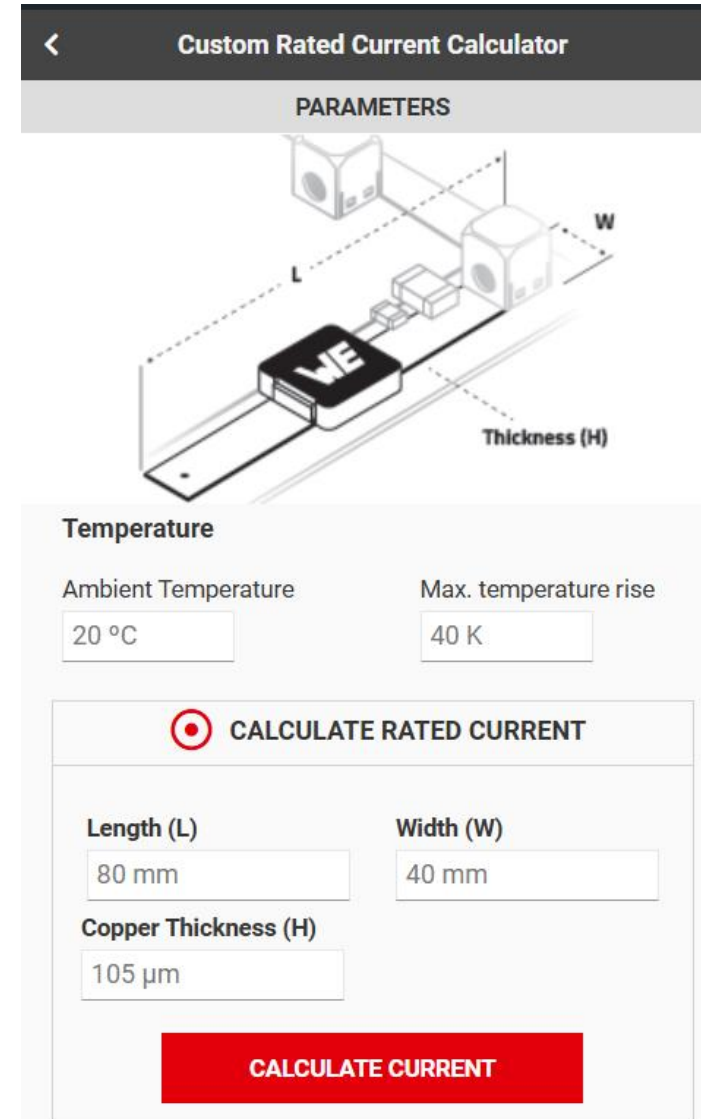

Custom Rated Current Calculator

PARAMETERS

Temperature

Ambient Temperature: 20 °C

Max. temperature rise: 40 K

CALCULATE RATED CURRENT

Length (L): 80 mm

Width (W): 40 mm

Copper Thickness (H): 105 μm

CALCULATE CURRENT

KEY TAKE AWAYS

1. Traditional datasheets miss up to 65% of total losses. DC resistance and saturation current alone are not enough.
2. REDEXPERT uses real hardware measurement data rather than simplified models to provide an accurate view of losses and thermal performance at your exact operating conditions.
3. Always verify inductance roll-off under load and temperature before finalizing your inductor choice. Use the RedExpert slider.
4. PCB trace dimensions affect your rated current. Use the Rated Current Calculator to validate your layout assumptions.
5. RedExpert is completely free. There is no reason not to use it. Visit redexpert.we-online.com today.



ST EDESIGNSUITE AND EDSIM SIMULATION TOOLS

Victor Ceron
Product Marketing Engineer
Central US
Analog and Power

REDEXPERT®



DESIGN AND SIMULATION TOOLS



STREAMLINE YOUR DESIGN PROCESS

1 Specify the application use case

	Non Isolated	Buck, Multi-Output Buck, Boost, Buck-Boost
	Isolated	Buck, LLC
	Non Isolated	Buck, FF-Flyback, PFC Pre-Regulation
	Isolated	FF-Flyback, QR-Flyback, PWM Controllers

3 Analyze time & frequency domain results, efficiency, and losses

5 Simulate the circuit with: Online simulations & eDSim



2 Select from the suggested ICs, the ones with specific features

4 Refine the specifications of the project

6 Export the CAD file to start the prototyping phase

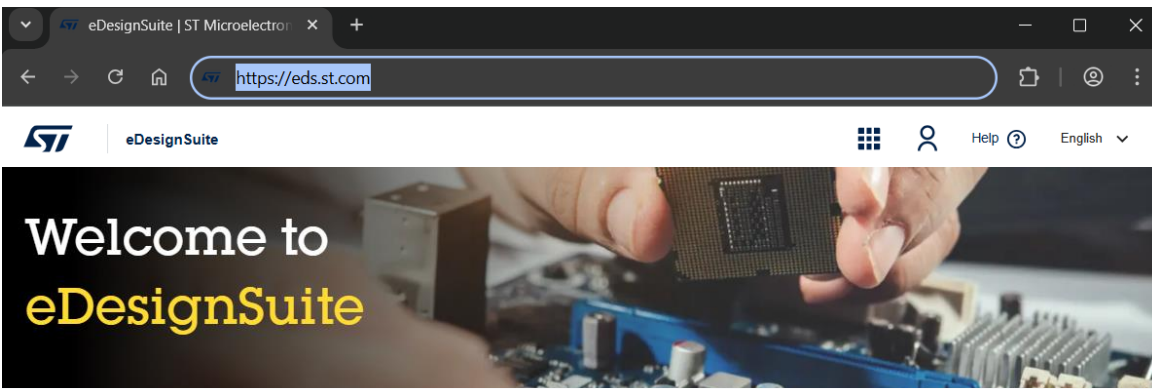

Power Management Design Center

Our on-line Power management design center helps designers accelerate the engineering development process for switch-mode power converters in a variety of topologies and configurations suitable for power supply, LED lighting and battery charger applications based on a large - and growing - number of ICs and Discrete from our broad portfolio.

[Explore all features](#)



Power Supply Design Tool

Streamline the development of AC-DC and DC-DC switch-mode Power Supplies with the Power supply design tool.



Start a new project



LED Lighting Design Tool

Learn how to design AC-DC and DC-DC switching converters for LED driver applications.

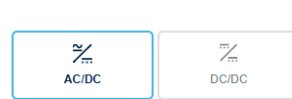

Start a new project

1

Navigate to <https://eds.st.com>

2

Click DC-DC new design

- 3 Insert target parameters
- 4 Select the solution
- ... Enjoy the simple design process

Power Supply Design Tool

eDesignSuite > Power Management Design Center > Power Supply Design Tool - DC/DC

Compare Grid view List view

SPECIFICATIONS		
Input	Min voltage (V)	Max voltage (V)
	12	24
Output	Voltage (V)	Current (A)
	5	1

DCP3601CDMR SOT23-6L

Buck

Vin: 3.5 - 36 V
Vout: 0.85 to 0.85 * Vin
Iout: ≤ 1 A
fosc: 1 MHz

[View product details](#)

[Customize solution](#)

DCP3601CMR SOT23-6L

Buck

Vin: 3.5 - 36 V
Vout: 0.85 to 0.85 * Vin
Iout: ≤ 1 A
fosc: 1 MHz

[View product details](#)

[Customize solution](#)

DC/DC CONVERTER SPECIFICATIONS

IC: DCP3601CDMR
Topology: BUCK
Input: 12 - 24 V
Output: 5 V (2% ripple) - 1 A max
[CHANGE SPECIFICATIONS](#)

OPERATING CONDITIONS

from 12 to 24 V
@Vin: V
 from 133 mA to 1 A
@Iout: A
 from -40 to 150 °C
@Ta: °C

ACTUALS

Vout: 5 V
ripple: 2 mV - 0.03 %
IL ripple: 195 mA - 19.45 % of 1 A
fsw: 1 MHz
Ton: 424.94 ns
Vin ripple: 0.49 %
bandwidth: 36.08 kHz
phase margin: 69.2°
IC Tj: 32 °C
ΔTj: 7 °C

Circuit - Schematic

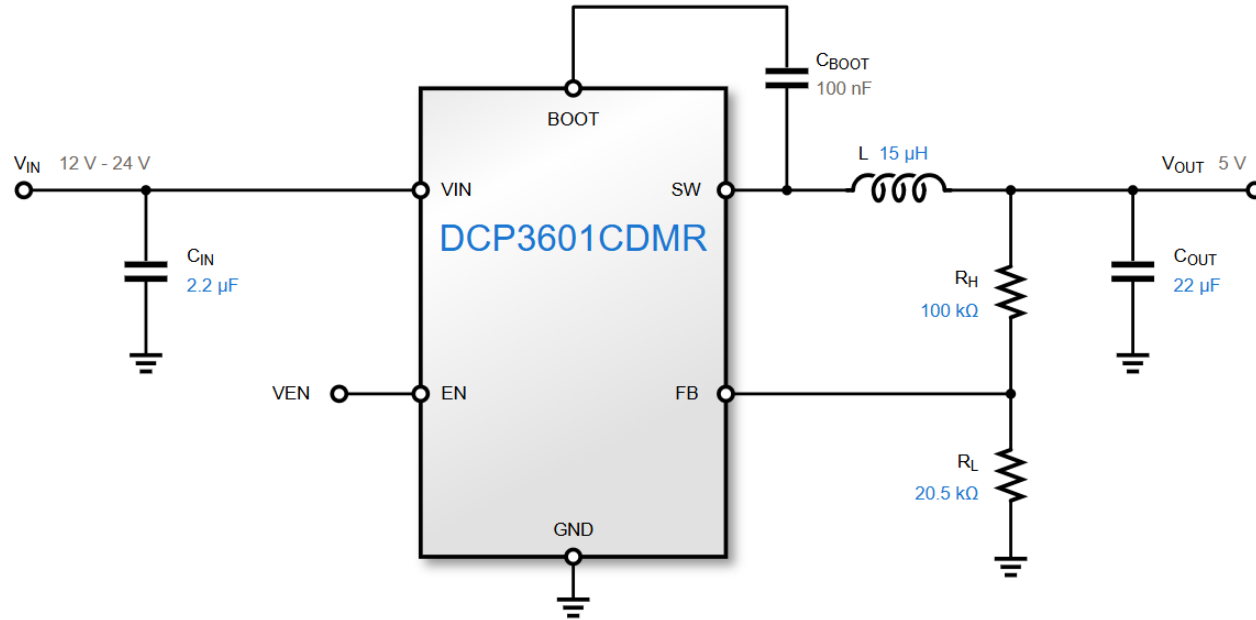

Circuit - BOM

Type	Ref	Value	Description
ST IC	IC	DCP3601CDMR	DCP3601CDM...
Capacitor	Cin	2.2 μF	50 V - 10% - m...
Capacitor	Cout	22 μF	25 V - 20% - T...
Inductor	L	15 μH	3.9 A
Resistor	Rh	100 kΩ	Resistor value...
Resistor	Rl	20.5 kΩ	Resistor value...
Capacitor	Cboot	100 nF	100 nF

Simulation: duty cycle 42.5 %

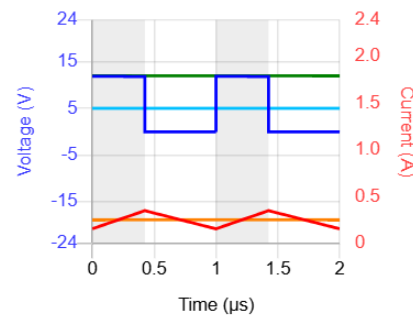

Efficiency: 91.8 %

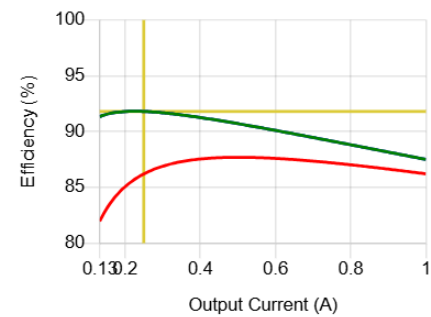

Bode: fc = 36.08 kHz - phase margin = 69.2 °

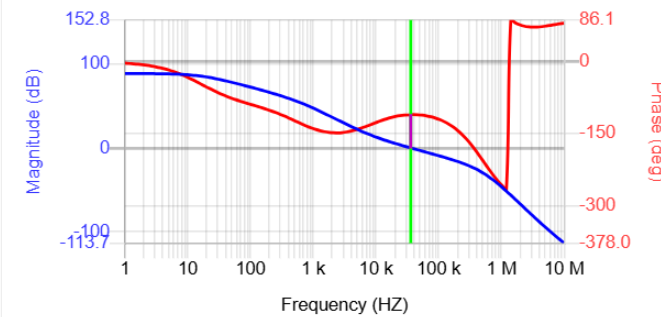

Losses: 112 mW - 8.2 %

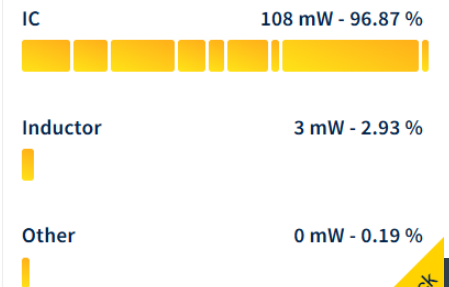

EDESIGN SUITE DEMO



NEW FAST AND POWERFUL SIMULATOR FOR SMPS AND ANALOG ICs

Crunch your electrical simulation 10-50 times faster than traditional analog SPICE simulators

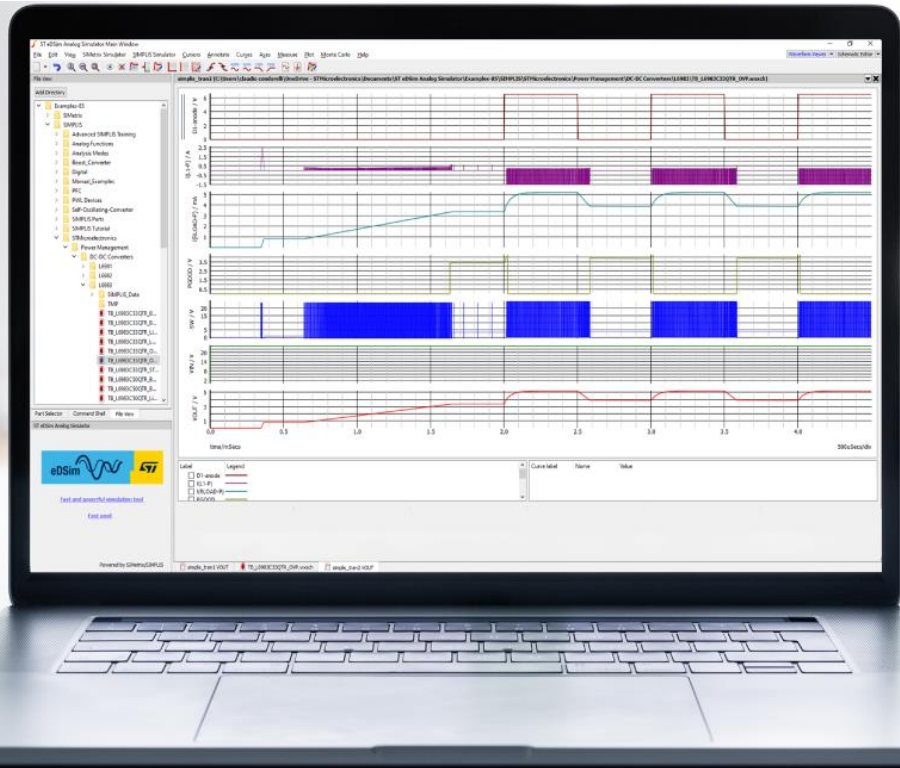

- 10 to 50 times faster than SPICE when simulating SMPS
- Time and frequency domain simulations
- Provide Loop stability with Bode plots
- Based on SIMPLIS engine, in line with main competitors



DC-DC converters (buck, USB-PD...)

AC-DC converters (up to 100 W, ...)

Power MOSFETs (SJ, SiC, LV)

Analog (op amps, CSA, COMPs...)

TVS discrete

Diodes, SCRs, triacs

Control stage



eDSim product page



eDesignSuite console



2022

2023

2024

Available

Proposal

RED EXPERT®



28



File View

Add directory Sync to Active

- SIMPLIS Parts
- SIMPLIS Tutorial
- STMicroelectronics
 - Power Management
 - AC-DC Converters
 - DC-DC Converters
 - A6983
 - TB_A6983C33QTR_B...
 - TB_A6983C33QTR_B...
 - TB_A6983C33QTR_Li...
 - TB_A6983C33QTR_L...
 - TB_A6983C33QTR_O...
 - TB_A6983C33QTR_O...
 - TB_A6983C33QTR_S...
 - TB_A6983C50QTR_B...
 - TB_A6983C50QTR_B...
 - TB_A6983C50QTR_Li...

Search by filename

Limit search to selected directories

Part Selector Command Shell File View

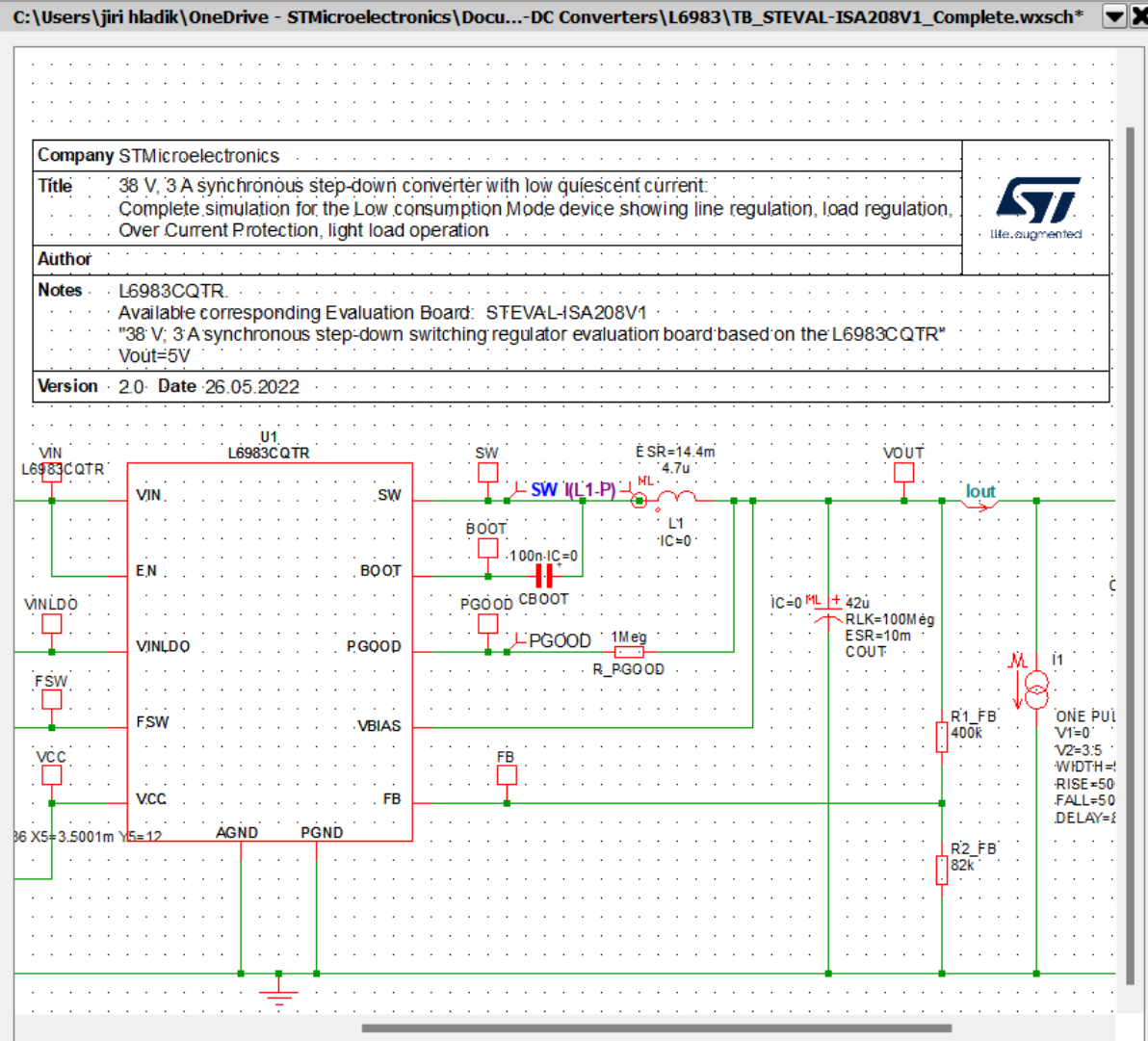

simplis_tran27 (C:\Users\jiri hladik...3\TB_STEVAL-ISA208V1_Complete.wxsch)

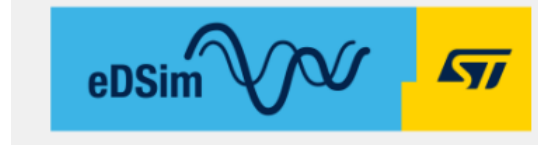
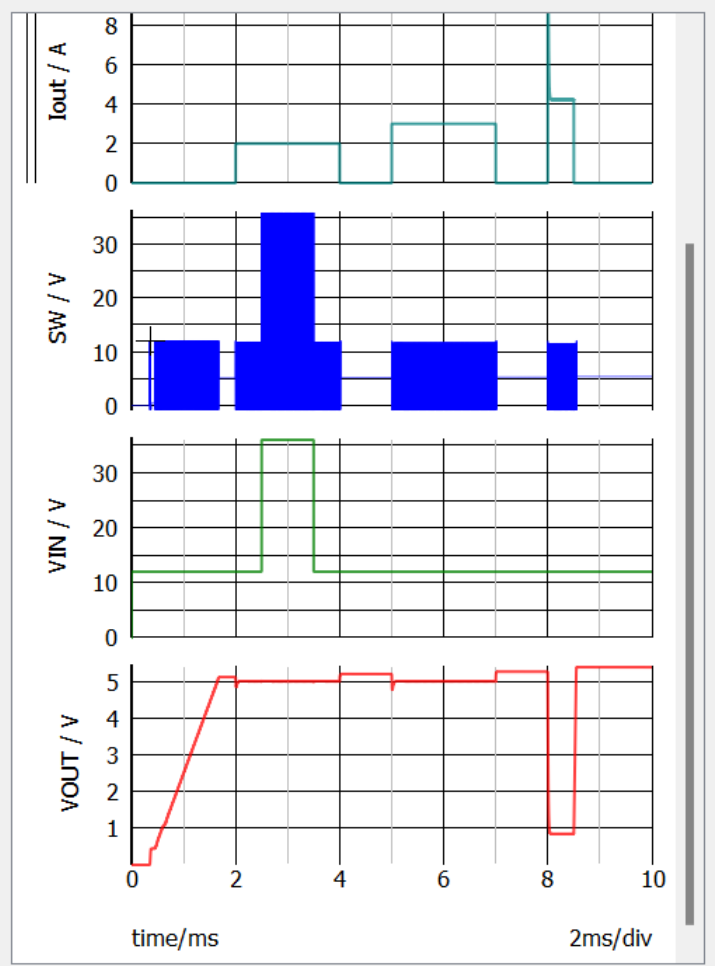

Fast and powerful simulation tool

eDSim ver. 2024.07. Check for Updates from Help menu

DC-DC STEP-DOWN CONVERTER 36 V, 1 A:
DCP3601

PRODUCT OVERVIEW:

DC+ 3601

36 V, 1 A high efficiency monolithic step-down converter industrial grade



Wide input voltage range up to 36 V

1 MHz fixed switching frequency

Synchronous rectification

LCM for high efficiency at light loads

LNM for noise-sensitive applications

Frequency dithering for improved EMC performances

OVP, thermal shutdown

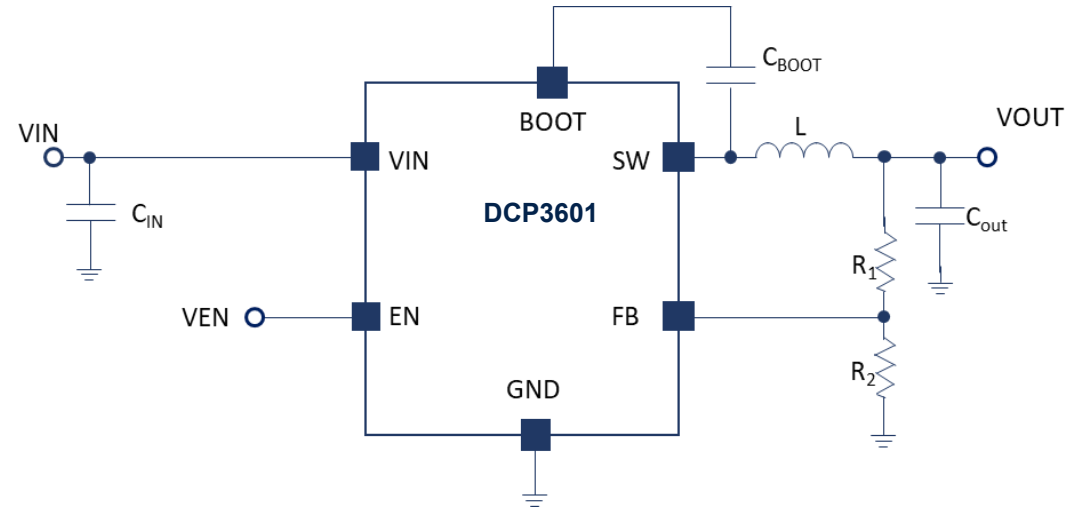

Part Number	Dithering	Light Load
DCP3601CMR	OFF	LCM
DCP3601NMR		LNM
DCP3601CDMR	ON	LCM
DCP3601NDCMR		LNM



Eval Board
STEVAL-3601CV1



Industrial
12V & 24V Bus
Conversion



Major
Appliances



Smart
metering



AVAILABLE VERSIONS: DCP3601

36 V, 1 A high efficiency monolithic step-down converter

Order codes	Marking	Light load Behavior	Dithering	Package	Packing
DCP3601CMR	01C	LCM (Low Consumption Mode)	No	SOT23-6L	Tape and reel
DCP3601NMR	01N	LNМ (Low Noise Mode)	No		
DCP3601CDMR	01CD	LCM (Low Consumption Mode)	Yes	SOT23-6L	Tape and reel
DCP3601NDMR	01ND	LNМ (Low Noise Mode)	Yes		



AL APPLICATION FOR DCP3601

Pinout - top view

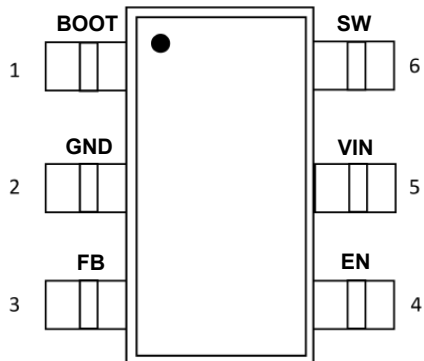

Name	Pin description
BOOT	Bootstrap supply for the high side gate driver
GND	System ground
FB	Output voltage feedback
SW	Switching node
VIN	Input voltage
EN	Enable

Typical application

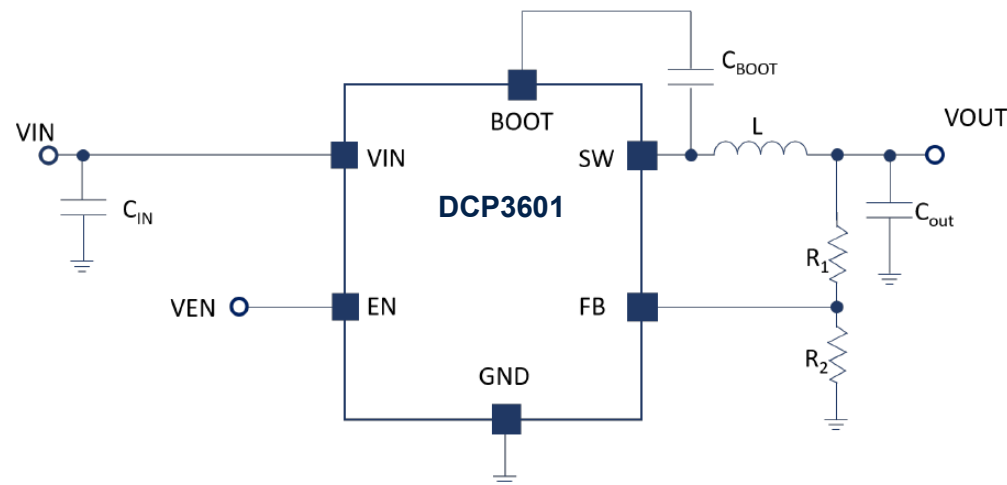

Typical BOM

Table 1. Typical external components

VOUT	L	CIN ⁽¹⁾	COU ⁽¹⁾	CBOOT ⁽¹⁾	R1	R2
5.0 V	15 μ H	2.2 μ F / 50 V	22 μ F / 25 V	100 nF / 50 V	73.2 k Ω	15 k Ω
	744393305150 - Wurth	C2012X7R1H225K125AC - TDK	C2012X5R1E226M125A - TDK	C1608X7R1H104K080AA - TDK	-	-
3.3 V	10 μ H	2.2 μ F / 50 V	22 μ F / 25 V	100 nF / 50 V	86.6 k Ω	30 k Ω
	744393305100 - Wurth	C2012X7R1H225K125AC - TDK	C2012X5R1E226M125A - TDK	C1608X7R1H104K080AA - TDK	-	-

1. Ceramic capacitor.



EFFICIENCY MEASUREMENT: 24 V TO 5 V

Efficiency comparison

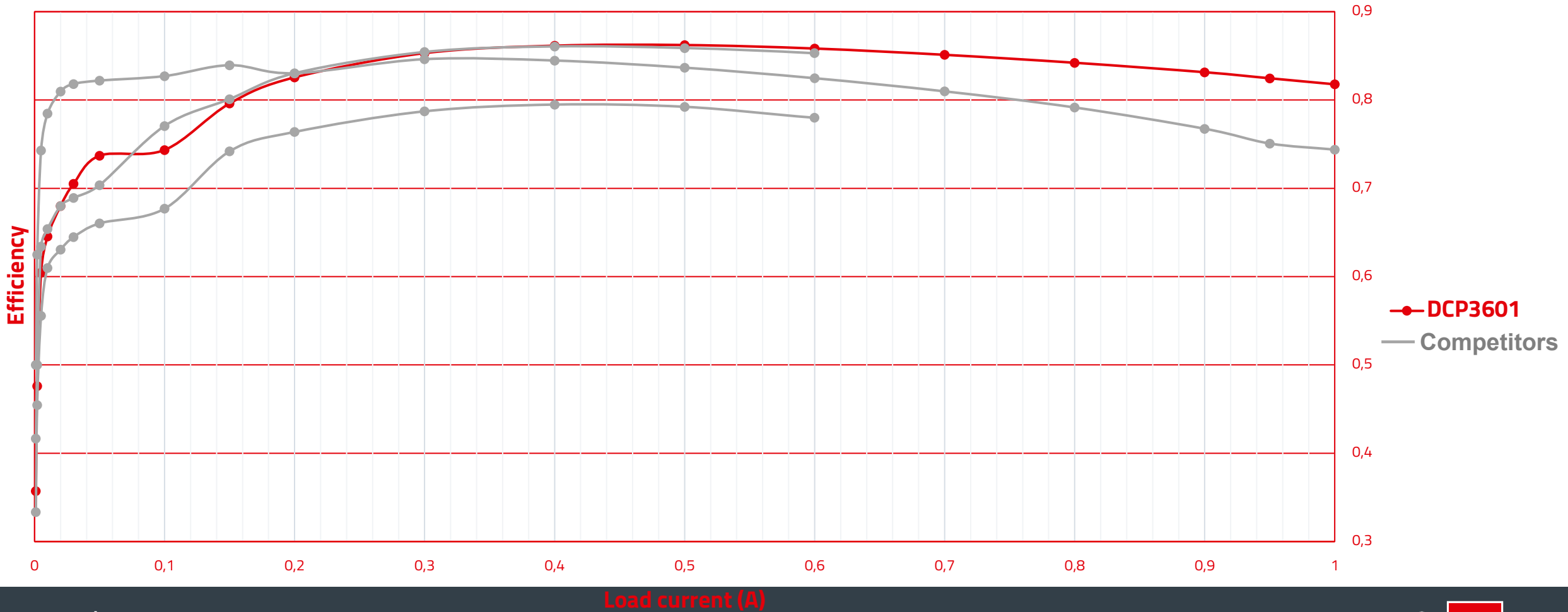



STEVAL-3601CV1

D3601 EVALUATION BOARD

36 V, 1 A synchronous step-down converter evaluation board

Evaluation board

STEVAL-3601CV1

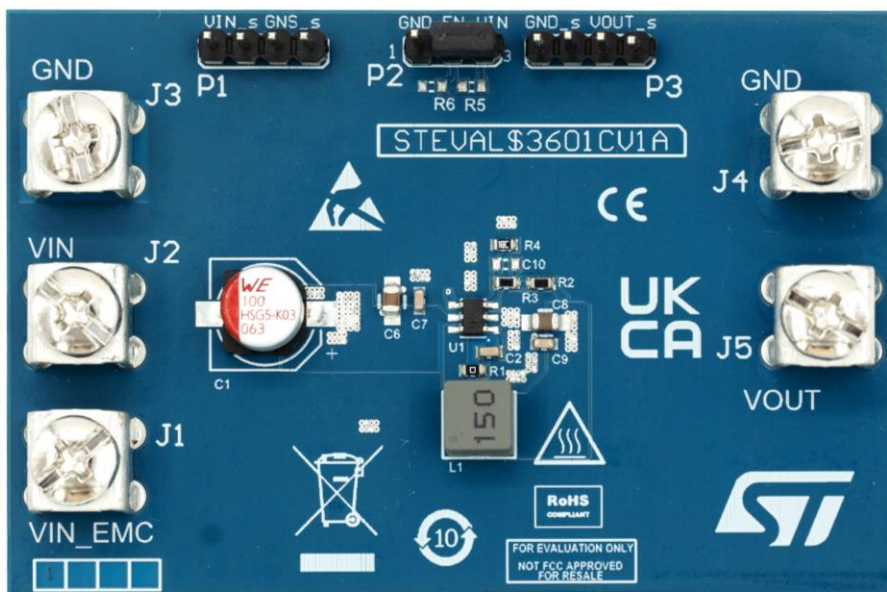

The STEVAL-3601CV1 demonstrates how highly efficient conversion can be achieved with just the DCP3601, an inductor, two small capacitors, and two resistors.

Features

- Minimum configuration 6 components
- 110 μ A input quiescent current
- 1 MHz fixed switching frequency
- Up to 36 V input operating voltage range
- 5 V output voltage
- Synchronous rectification
- Internal compensation network
- Peak current mode control
- Precision enable
- WEEE, CISPR16-4-2 and RoHS compliant





HEAT THERMAL CHARACTERISTIC

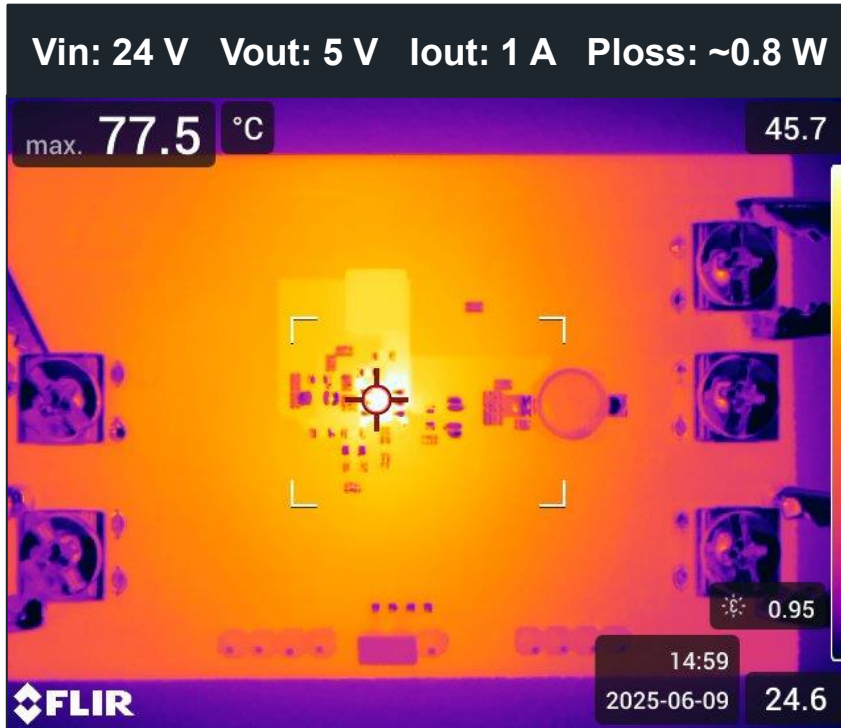
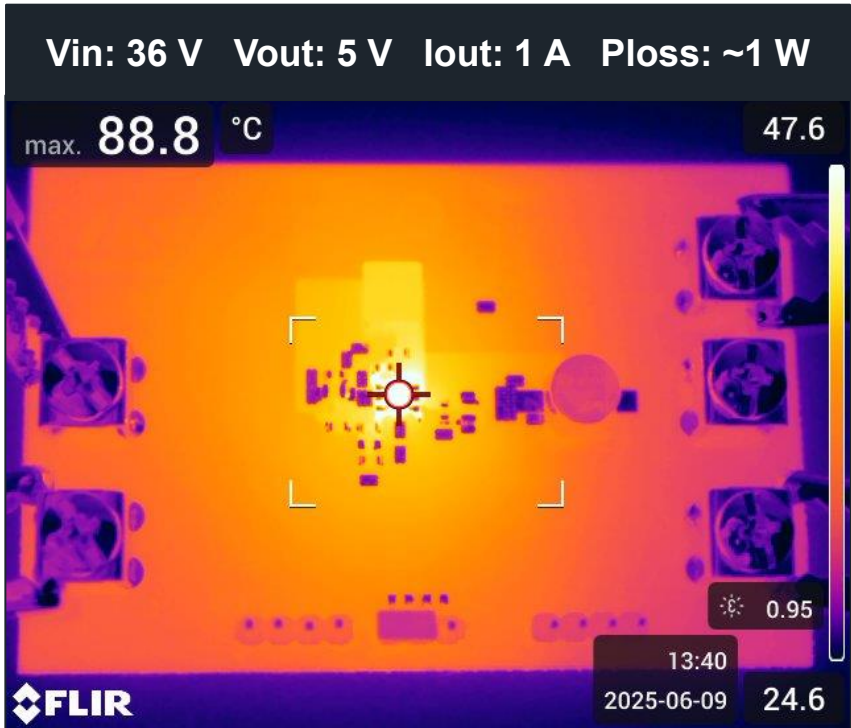

STEVAL-3601CV1

Board parameters

- 4-layers PCB
- Plating 70 μm copper
- Size 70 x 46 mm

↓

Total RthJA ~75°C/W

It can manage 24 V → 5 V @ 1 A at ambient temperature of 80°C

Symbol	Parameter	Value
RthJA	Thermal resistance junction-ambient	160°C/W
RθJC(top)	Junction-to-case (top) thermal resistance	106°C/W
RθJB	Junction-to-board thermal resistance	55°C/W
ψJT	Junction-to-top characterization parameter	29°C/W
ψJB	Junction-to-board characterization parameter	61°C/W

Note: these values were calculated in accordance with JESD specification and simulated on a 4-layer (2s2p) JEDEC board.



DCP360X USE IN 12 V AND 24 V INDUSTRIAL APPLICATIONS

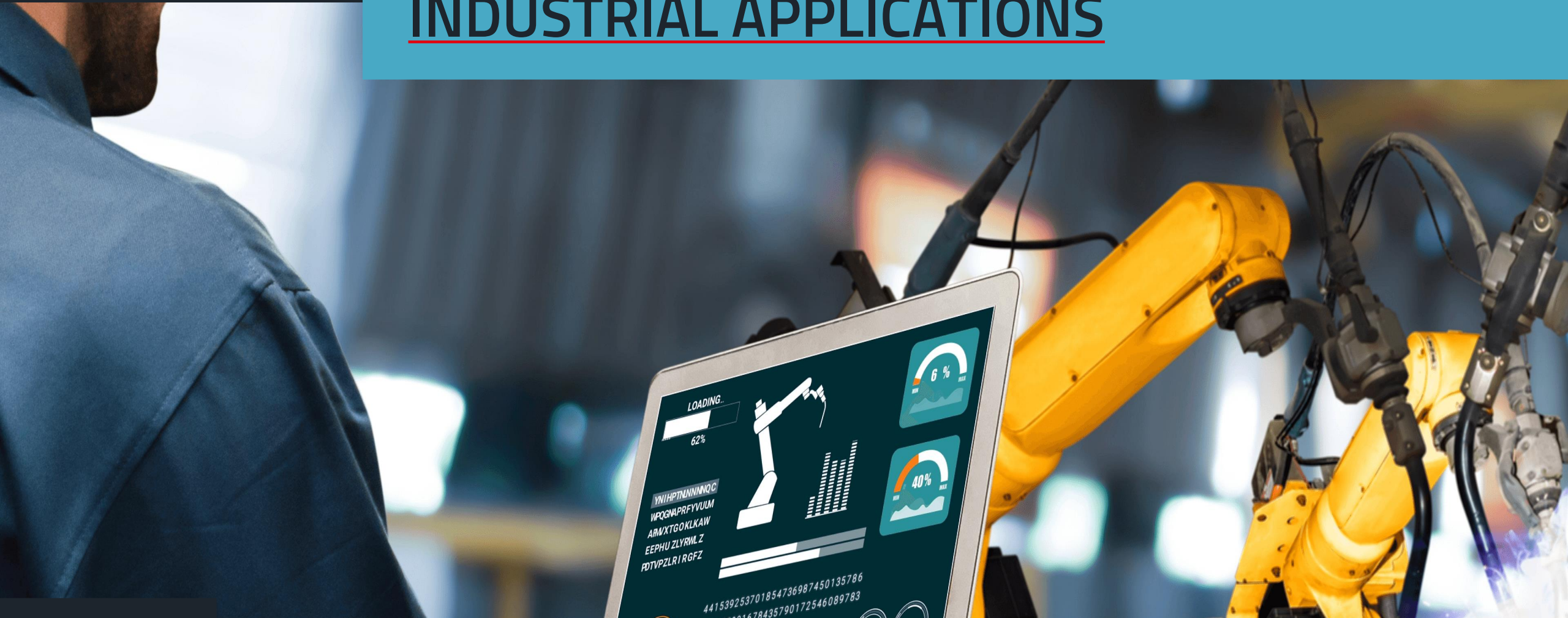

USE IN 12 V AND 24 V INDUSTRIAL APPLICATIONS

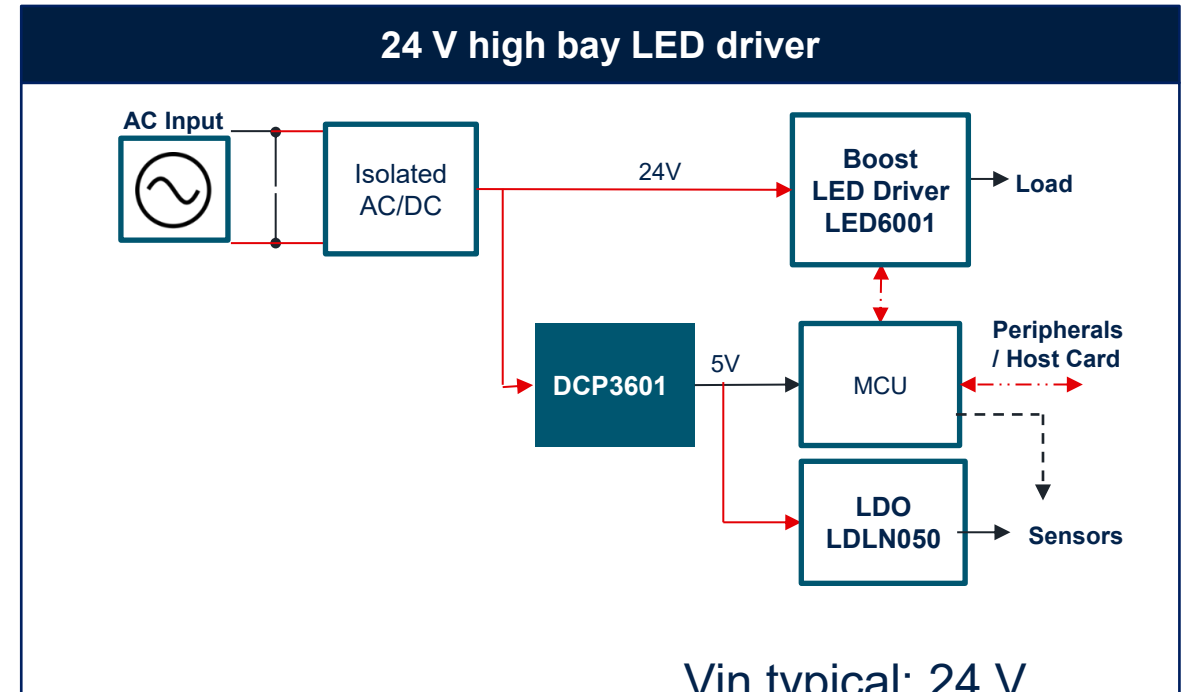
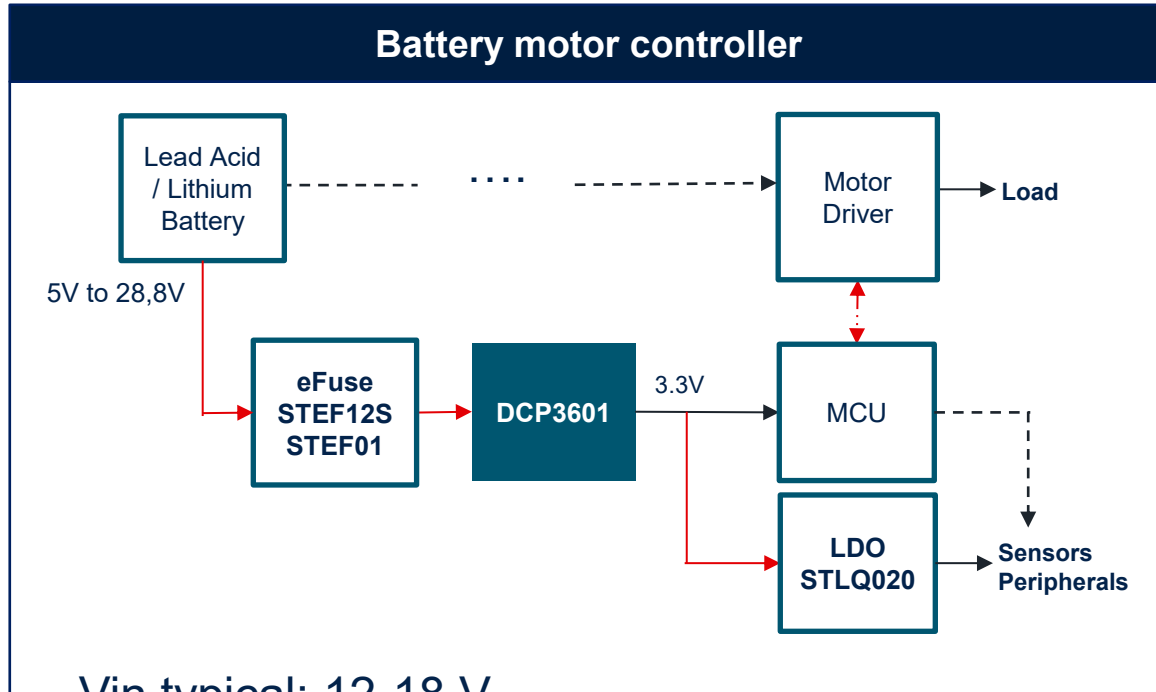

Vin typical: 12-18 V
 Vout typical: 3.3 V
 Iout max: 0.8 A
 ↓
 Efficiency: 85.1%

Vin typical: 24 V
 Vout typical: 5 V
 Iout max: 0.6 A
 ↓
 Efficiency: 87.6%

- ### Typical application features
- Power supply for embedded MCUs (STM32 like), sensors, peripherals, etc.
 - As simple as possible
 - Low BOM count
 - Small PCB area

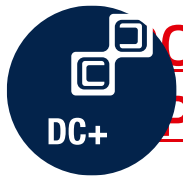

PRODUCT OVERVIEW:

D3603

36 V, 3 A high efficiency monolithic step-down converter

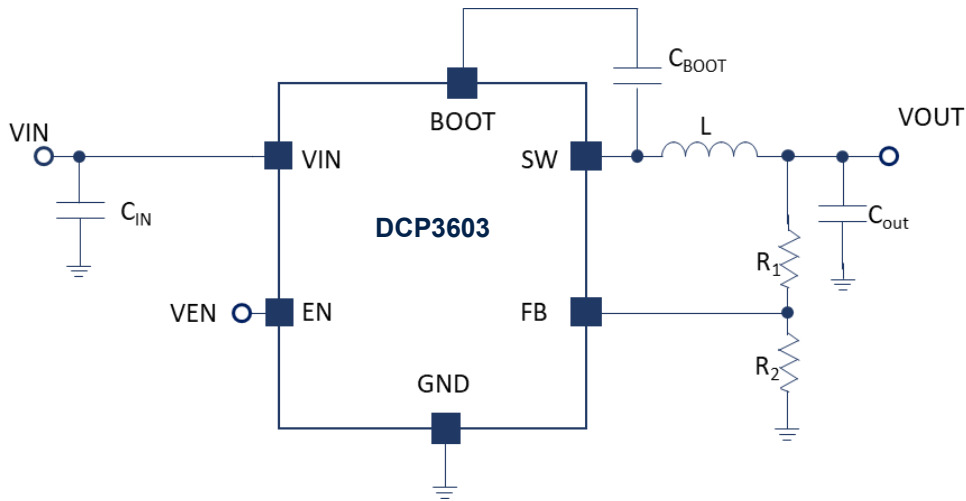

Key applications

- Major appliances
- Smart metering
- Industrial 24 V bus conversion

Key benefits & features

- Pin-to-pin with DCP3601
- 3.3 to 36 V input operating range
- Up to 3 A output current capability
- 110 μ A operating quiescent current.
- 500 kHz and 1 MHz fixed switching frequency
- Synchronous rectification
- Internal compensation network
- LCM for high efficiency at light loads and LNM for noise sensitive applications
- Overvoltage protection
- Thermal shutdown
- Precision enable
- Frequency dithering



SOT23-6

Part Number	Freq	Dithering	Light Load
DCP3603ACMR	500 kHz	OFF	LCM
DCP3603BCMR	1 MHz		
DCP3603ACDMR	500 kHz	ON	LCM
DCP3603BCDMR	1 MHz		
DCP3603ANMR	500 kHz	OFF	LNM
DCP3603BNMR	1 MHz		
DCP3603ANDMR	500 kHz	ON	LNM
DCP3603BNDMR	1 MHz		



DCP3601 & DCP3603 COMPATIBILITY

Simple scalability for 1 A and 3 A output

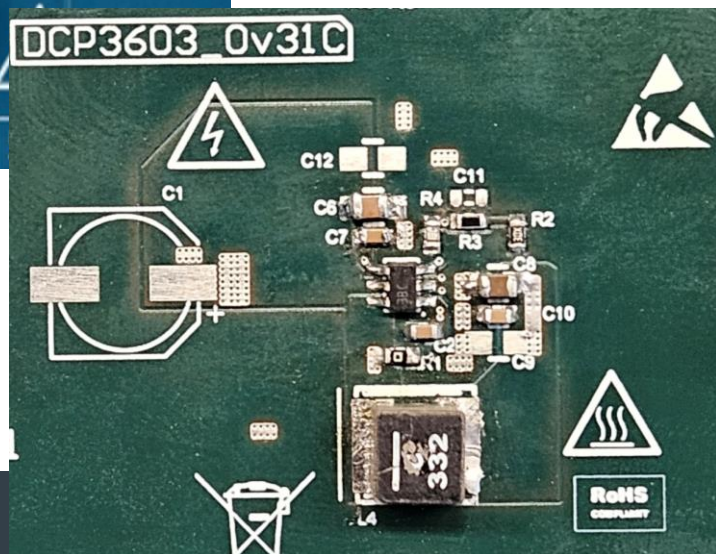
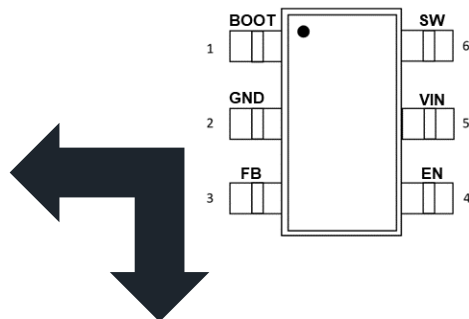
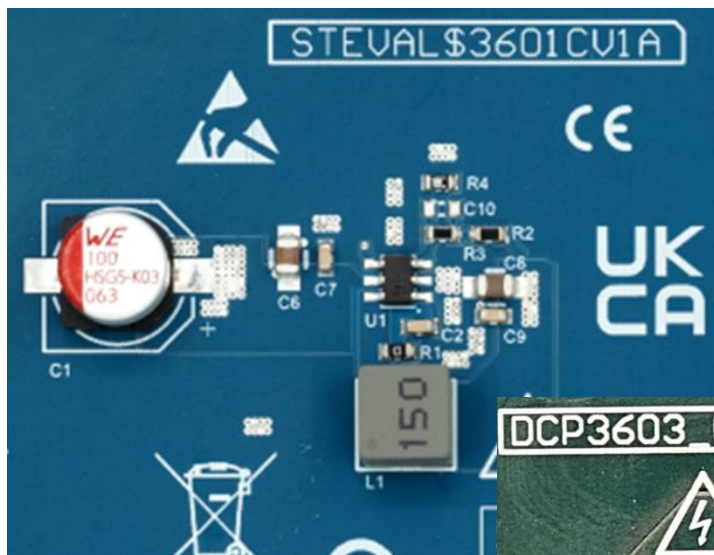

Features

- Identical package and pinout
- Similar BOM
 - Smaller inductor value (same size)
 - Possibly bigger value output capacitor

Key benefits

- Same PCB layout
 - Can be shared and optimized across more projects
- Scalability for 1 A and 3 A supplies

EDSIM DEMONSTRATION

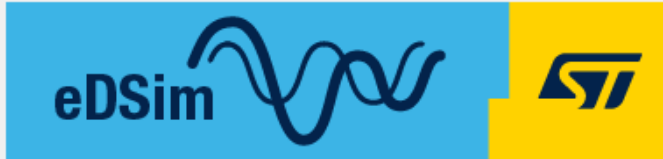

Fast and powerful simulation tool

eDSim is a fast and powerful electrical simulation tool for SMPS and Analog ICs.

It features enhanced accuracy and convergence time for SMPS, enabling simulation time 10-50x faster than classical SPICE simulators.

SMPS Application Circuits **Export for eDSim** capability is integrated into **eDesignSuite** tools.

The tool features:

- Built-in interface with eDesignSuite
- Time domain simulation
- Control loop stability
- Pre-defined Application case simulation
- Schematic editor for customization
- Waveform viewer with measurements capabilities



ST eDSim Main Window

File Edit View Simulator Place Probe Probe ΔC/Noise Hierarchy Monte Carlo Tools Help

Web View Schematic Editor

File View

Add Directory Sync to Active

Examples-85

- SIMetrix
 - 4046_PLL
 - 74297_PLL
 - ALB_Examples
 - Analog_Blocks
 - Bridge
 - Cascomp
 - CMOS
 - Digital_Devices
 - Flyback_PSU
 - flyback.sxsch
 - General
 - Generic_AD_conversion
 - generic_dig
 - hierarchv

Part Selector Command Shell File View

ST eDSim

100kHz current-mode off-line flyback converter

This is a complete off-line current mode switching PSU running at 100kHz.

This circuit was developed to test and demonstrate the UC3844 model and should not be seen as a useable design.

Select X 0.72 SIMetrix

Welcome flyback.sxsch

Powered by SIMETRIX/SIMPLIS

EDSIM OVERVIEW (2)

2 Supported devices

SIMPLIS ICs models for Power Supply

Power Conversion

AC/DC

- Isolated
 - Quasi Resonant Flyback
 - **VIPERGAN50**: VIPERGAN50TR
 - **VIPERGAN65**: VIPERGAN65TR
 - **VIPERGAN100**: VIPERGAN100TR
 - **VIPER25**: VIPER25HD, VIPER25LD
 - **VIPER35**: VIPER35HD, VIPER35LD
 - Isolated
 - Fixed Frequency Flyback
 - **VIPER26K**: VIPER265K, VIPER267K
- Not Isolated
 - Buck
 - **VIPER26K**: VIPER265K, VIPER267K
 - **VIPER31**: VIPER317HD, VIPER317LD, VIPER318HD, VIPER318LD, VIPER318XD, VIPER319HD, VIPER319LD, VIPER319XD
 - **VIPER11**: VIPER113LS, VIPER115XS, VIPER115LS, VIPER115HS, VIPER114XS, VIPER114LS, VIPER114HS, VIPER113XS
 - **VIPER01**: VIPER011LS, VIPER011XS, VIPER012HS, VIPER012LS, VIPER012XS, VIPER013HS, VIPER013LS, VIPER013XS

DC/DC

- Not Isolated
 - Buck
 - **A/L6983**: A/L6983CQTR, A/L6983C33QTR, A/L6983C50QTR, A/L6983NQTR, A/L6983N33QTR, A/L6983N50QTR
 - **L6981**: L6981C33DR, L6981C50DR, L6981CDR, L6981N33DR, L6981N50DR, L6981NDR
 - **L6982**: L6982C33DR, L6982C50DR, L6982CDR, L6982N33DR, L6982N50DR, L6982NDR
 - **L7983**: L7983PU50R, L7983PU33R, L7983PUR
 - **ST1PS01**: ST1PS01AJR, ST1PS01BJR, ST1PS01CJR, ST1PS01DJR, ST1PS01EJR, ST1PS01FJR, ST1PS01GJR, ST1PS01HJR
 - **ST1PS02**: ST1PS02AQTR, ST1PS02BQTR, ST1PS02CQTR, ST1PS02DQTR
 - **ST1PS03**: ST1PS03A1QTR, ST1PS03AQTR
 - **L3751**: L3751PUR
 - ***A/L7987***: L7987, L7987L, A7987
 - **STPD01**: STPD01PUR
 - ***A/L6986***: L6986TR, A6986TR
- Isolated
 - Iso-Buck/Iso-Buck-Boost
 - **A/L6986I**: A/L6986ITR
 - **A/L6983I**: A/L6983IQTR

Led Driver

DC/DC

- Boost
 - **ALED7709**

SIMetrix ICs Models for Linear Analog

Amplifiers

- Operational Amplifiers
 - TSB582, TSV620, TSV621, TSV611, TSV521, TSB611, TSX631, TSX561, TSV771, LM2904, LMV321, LMV620, LMV821, TSV791, TSZ121, TSZ181, TSV911, TSV991, TSV631, TSV630, TSB511, TSB711, TSU111, TSV711, TSV731, TSU101, TSB571, TSX711, TS507, TSX921, TSX920, TSV7721, TSV7723_SINGLE, TSV781, TSV782, TSB181, TSB182, RHF43B_BOL/EOL/EOR, RHF200_BOL, RHF310_BOL/EOL/EOR, RHF330_BOL/EOL/EOR, RHF350_BOL/EOL/EOR, RHF484_BOL/EOL/EOR, RHR61_BOL, RHR64_BOL, TS1851, TS1871, TS617, TSB7191, TSH300, TSH310, TSH350, TSH330, TSV850-1, TSV6191, TSV6290-1, TSV6390-1, TSX7191, TSX9291
 - Current Sense Amplifiers
 - TSC2010, TSC2011, TSC2012, TSC1021A, TSC1021B, TSC1031, TSC103, TSC102, TSC101A, TSC101B, TSC101C, TSC200
 - Fully Differential Amplifiers
 - RHF200_BOL
- Comparators: TS3011, TS3021, TS881, TS880, TSX3702, TSX393, TS331, RHR801_BOL, TS985, TS7221

SIMetrix Models for TVS Electrothermal devices

- TVS
 - LDP01Y, SM4TY, SM6TY, SM15TY, SM30TY, SM50TY, SMA6TY, SM15T, SMCJ, SMC30J, SM6FY, SM6T, SMAJ, SMBJ, SMC50J, SMA6J

SIMPLIS/SIMetrix Models for Power MOSFET devices

- NMOS
 - SCT011H75G3AG_TN, SCT011H75G3AG_V2, SCT011H75G3AG_V2_3T, SCT011H75G3AG_V3, STL90N10F7_V2, STL325N4LF8AG_V3_3T, STL325N4LF8AG_V3, SCT011HU75G3AG, SCT015W120G3-4AG, SCT040HU120G3AG, SCT070HU120G3AG, SCTHS250N120G3AG, STL170N4LF8, STL160N10F8, STL300N4LF8, STP80N340K6, STP60N043DM9, STW65N045M9-4, STD80N240K6, STWA65N023M9, STD80N340K6, STWA65N045M9, STP80N450K6, STP65N045M9, STD80N450K6, STP65N150M9, STP80N600K6, STP80N900K6, STP80N1K1K6, STW65N023M9-4, STH60N099DM9-2AG, STWA60N043DM9, STP80N240K6, STD65N160M9, SCT020HU120G3AG, STL117N4LF7AG, STL135N8F7AG, STL64DN4F7AG, SH32N65DM6AG, SH68N65DM6AG, STB47N50DM6AG, STB47N60DM6AG, STD12N60DM6, STF24N60M6, STH2N120K5-2AG, STH13N120K5-2AG, STH30N65DM6-7AG, STL45N60DM6, STL52N60DM6, STO67N60M6, STW12N120K5, STW12N150K5, STW50N65DM2AG, STWA65N65DM2AG, STWA75N60M6, SCT025W120G3-4AG, SCT027W65G3-4AG, SCT040W65G3-4AG, SCT055W65G3-4AG, SCT060HU75G3AG, SCT070W120G3-4AG

SIMetrix Models for Thyristors devices

- Thyristors
 - ACS108-8TN, ACST1235-8FP, ACST1635-8FP, ACST1635T-8FP, ACST2, ACST310-8B, ACST4, ACST6, BTA25, BTA40, BTA41-800BL, BTB04-600SL, BTW67, BTW69-600RG, BTW69-800, P0102BL, P0102MN, T1035, T1050, T1210, T1210T-6I, T1210T-8G, T1210T-8T, T1220T-6I, T1225T-6I, T1235H-8G, T1235H-8I, T1235H-8T, T1235T-8G, T1235T-8I, T1235T-8R, T1235T-8T, T1605G-6I, T1610T-8G, T1610T-8I, T1610T-8T, T1620T-8G, T1625T-8I, T1635H-8G, T1635H-8I, T1635H-8T, T1635T-8G, T1635T-8I, T1635T-8T, T2035H-8G, T2035H-8I, T2035H-8T, T2035T-8G, T2050H-6G, T2535T-8G, T2535T-8I, T2535T-8T, T2650-6PF, T3035H, T3035H-8G, T3035H-8I, T3035H-8T, T3050H, T4050-6PF, T405T-6FP, T435-600T11F4, T435T-600FP, T610T-8T, T635T-8T, T810T-6I, T810T-8G, T810T-8T, T820T-6I, T825T-6I, T835, T835H-8G, T835H-8I, T835H-8T, T835T-6I, T835T-8G, T835T-8I, T835T-8T, T850, TM8050H-8D3, TM8050H-8W, TN1205H, TN1205T-600, TN1215, TN1515-600B, TN1605H-6G, TN1605H-6T, TN1610H-6I, TN1610H-6T, TN2010H-6G, TN2010H-6I, TN2010H-6T, TN2015H-6I, TN2015H-6T, TN2540-12G, TN3015H-6G, TN3015H-8I, TN3015H-8T, TN3050H-12GY-TR, TN3050H-12LY, TN3050H-12WY, TN4015H-6G, TN4015H-6I, TN4015H-6T, TN4050-12PI, TN5015H-6G, TN5015H-6I, TN5015H-6T, TN6050-12PI, TN6050HP-12WY, TN815, TS420-600BC, TS820, TXN625, TXN825RG, TYN1225, TYN606, TYN608, TYN610, TYN616, TYN625, TYN640, TYN816, TYN825, TYN840, X0115MU, Z0109M1, DB3TG_STM, DB3_STM, DB4_STM, SMDB3_STM, TMMDB3TG_STM, TMMDB3_STM

E Browse to www.st.com/edsim
Click on "Get Software" button

The screenshot shows a web browser window with the URL `st.com/en/embedded-software/stsw-edsim.html`. The page header includes navigation links for **Careers**, **Sample & Buy**, and **Support & Community**, along with language options for **日本語**, **中文**, and **English**. The main navigation bar features the **ST** logo with the tagline *life.augmented*, a search icon, and menu items for **Products**, **Tools & Software**, **Applications**, **Solutions**, **STM32 Developer Zone**, and **About Us**. Below the navigation, a breadcrumb trail reads: **Embedded Software > Evaluation Tool Software > STSW-eDSim >**. The main content area displays the product name **STSW-eDSim** with a green **ACTIVE** badge and a **Save to MyST** button. The primary headline is **eDSim: fast and powerful electrical simulation software for SMPS and analog ICs**. At the bottom of this section, there are two buttons: a pink **Get Software** button and a white **Download databrief** button. A grey arrow points to the **Get Software** button.

Click "Get Latest" button

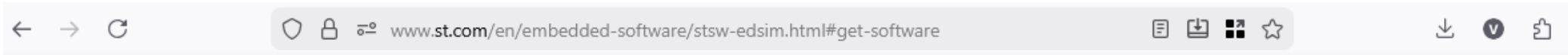

Get Software

Part Number ▲	General Description	Supplier ◆	Download ◆
+ STSW-eDSim	eDSim: fast and powerful electrical simulation software for SMPS and analog ICs	ST	Get latest



After careful review of the entire License Agreement,
Click on the **ACCEPT** button

The screenshot shows a web browser window with the address bar displaying www.st.com/en/embedded-software/stsw-edsim.html#get-software. The main content area contains a license agreement text. At the bottom right of the page, there are two buttons: "Decline" and "Accept". A grey arrow points to the "Accept" button.

referred to in this LLA as "You" or "Licensee") and STMicroelectronics International NV, a company incorporated under the laws of the Netherlands acting for the purpose of this LLA through its Swiss branch located at 39, Chemin du Champ des Filles, 1228 Plan-les-Ouates, Geneva, Switzerland (hereinafter "ST"). Affiliates shall mean any corporation, partnership, or other entity that, directly or indirectly, owns, is owned by, or is under common ownership with ST, for so long as such ownership exists. For the purposes of the foregoing, "own", "owned," or "ownership" shall mean ownership of more than fifty percent (50%) of the stock or other equity interests entitled to vote for the election of directors or an equivalent governing body.

The ST materials licensed under this LLA shall mean the software and/or any hardware material which accompany or are otherwise made available by ST and/or its Affiliates upon agreeing to this LLA, including any associated media, documentation (collectively the "Licensed Materials"). Documentation shall include any comments, annotations, instructions, manuals, and other materials, whether in printed or electronic form, including without limitation installation manuals, user's guides, and programmer's guides, related to any software and/or any hardware material made available under this LLA. The Licensed Materials include any software updates, hardware products and supplements that ST and/or its Affiliates may provide You or make available to You after

Decline **Accept**



Download "stsw-edsim.zip" (737MB file)
Extract ZIP and click on "ST_eDSim-setup.exe"
Follow prompts to install eDSim

Name	Type	Compressed size	Password ...	Size	Ratio	Date modified
 ST_eDSim-setup.exe	Application	737,368 KB	No	737,461 KB	1%	1/22/2026 10:54 AM



Make sure to open ST eDsim for the first time to finish the installation of key files and registry entries.

ST eDSim Main Window

File View

Add directory

- Examples-92
- STMicroelectronics

Search by filename

Limit search to selected directories

Command Shell | Part Selector | File View

ST eDSim

ST eDSim

Fast and powerful simulation tool

eDSim ver. 2025.12. Check for Updates from Help menu

Powered by SIMetrix/SIMPLIS

Welcome

life.augmented

Create New

- New SIMPLIS Schematic
- New SIMetrix Schematic

Recent Schematics

- Open...

STMicroelectronics Examples

You can find a list of example application schematics in the File Viewer:

- STMicroelectronics\SIMPLIS
- STMicroelectronics\SIMetrix

Support

- Getting Started
- End-user License Agreement
- Release Note
- eDSim Product Page
- Contents Update Settings

eDesignSuite is a comprehensive easy-to-use design aid tool supporting a wide range of ST products