

## REFERENCE DESIGN

### RD001 | 6 W Bipolar isolated auxiliary supply for SiC-MOSFET & IGBT gate driver



Eleazar Falco / Emil Nierges

#### 01.OVERVIEW

This reference design presents an extremely compact auxiliary power supply with a combined output power up to 6 W. Three different isolated bipolar output voltages are provided: + 15 V / - 4 V, + 19 V / - 4 V and + 20 V / - 5 V. The design is optimized for driving high-voltage SiC-MOSFET and IGBT discrete devices as well as power modules in high-power converters, and can be easily integrated in the gate driver system. The extremely low interwinding capacitance of the **WE-AGDT** transformers down to 7 pF helps to achieve high CMTI rating (Common-Mode Transient Immunity). This enables fast switching speeds which can yield efficiency and power density gains, as increasingly required in trending applications in e-mobility, renewable energy or industrial automation.



Figure 1: Board Image

#### Key Features

- Small size
- (Var.A: 27 mm × 14 mm × 14 mm) (Var.B: 40 mm × 14 mm × 13 mm)
- 4 kV primary-secondary isolation
- Only 7 pF typ. parasitic capacitance enabling high CMTI
- PSR Flyback topology with LT8302 (ADI Power by Linear)
- Load/line regulation less than 1% typ.
- Up to 88% peak efficiency (86% at 6 W)
- Standard and AEC-Q qualified component assembly variants
- Two PCB Layout Variants (2-layer and 4-layer)

#### Typical Applications

- E-mobility: Electric Powertrain
- On-board and Off-board battery chargers
- Industrial drives: AC motor inverter
- Renewable energy: Solar inverters
- Power factor correction (PFC) stages
- Switch-mode power supplies with SiC MOSFETs

# REFERENCE DESIGN

## RD001 | 6 W Bipolar isolated auxiliary supply for SiC-MOSFET & IGBT gate driver

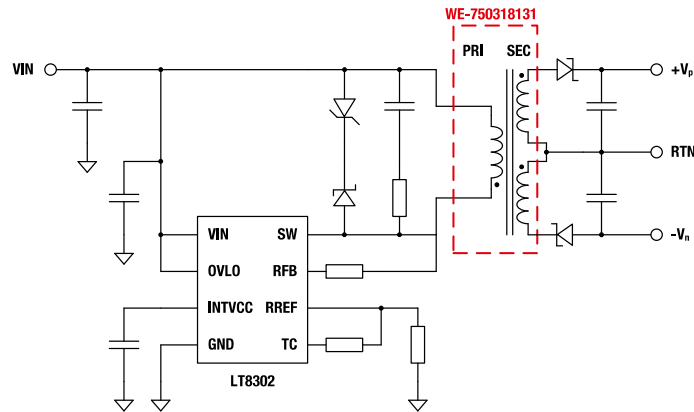

Figure 2: Simplified circuit schematic

## 02. TECHNOLOGY AND SYSTEM DESIGN CONSIDERATIONS

Silicon Carbide (SiC) technology is enjoying growing popularity in medium and high voltage power switching applications (typically above 300 V). The extremely fast switching speed of SiC-MOSFETs, their low on-resistance and excellent thermal performance (conductivity and stability) are some of the key advantages against its Silicon-based counterparts. SiC devices are thus starting to replace silicon-based devices like IGBT (Insulated Gate Bipolar Transistor) and Power-MOSFETs in industries like E-mobility, industrial drives and renewable energy.

The voltage required across the gate-source terminals of a SiC-MOSFET are typically found in the range of + 15 to + 20 V for full turn-on and 0 to -5 V for robust turn-off. Note that a negative voltage is typically used for a faster turn-off transition as well as to keep the device off reliably, preventing spurious turn-on caused by parasitic resonant ringing or Miller-effect in hard-switched, half-bridge applications. This is caused by the very high  $dv/dt$  generated across the device terminals during fast switching transitions (see section 2.2). Some devices require only a unipolar gate drive voltage, and in such cases, the unipolar auxiliary supply reference design shown in [RD002](#) can be used instead.

### 2.1 Gate Driver, SiC-MOSFET and Auxiliary Power Supply System

A low-power isolated auxiliary supply, typically a flyback, push-pull or half-bridge topology, provides the gate drive voltage level and power required to switch on and off the SiC device, in addition to the galvanic isolation between the high-voltage and low-voltage sides. Isolation is a requirement not only to meet relevant safety standards, but also to reduce electrical noise improving EMI and gate driver control robustness. The transformer in the auxiliary supply fulfils this primary task. Regarding the gate driver stage, an isolated gate driver IC with an output transistor stage in push-pull/totem-pole configuration is typically used to drive the gate-source of the SiC device based on a control signal from the controller system. The system connection is shown below:

# REFERENCE DESIGN

## RD001 | 6 W Bipolar isolated auxiliary supply for SiC-MOSFET & IGBT gate driver

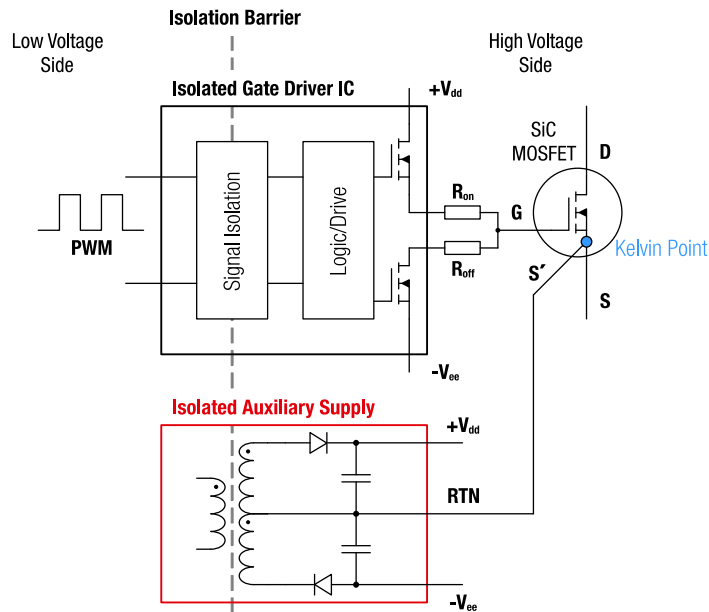

Figure 3: Connection of bipolar auxiliary supply with gate driver IC and SiC-MOSFET

Note that alternative implementations are also possible, for example using an external push-pull stage with discrete MOSFETs for higher peak current strength, or using a non-isolated gate driver IC plus a digital isolator or optocoupler providing the galvanic isolation of the PWM control signal. In all such cases, the connection to the auxiliary supply does not change from that shown in Figure 3 above.

It is also important to note that some SiC devices feature an additional Kelvin pin  $S'$  for the source terminal, as shown in the image. This connection provides a dedicated Gate-Source path for the gate drive current which is not 'shared' with the current of the power loop (Drain-Source) at the source terminal. This prevents common-source inductance issues during fast switching transitions, caused by the high  $dI/dt$  of the power loop current causing a voltage drop across the source parasitic inductance which opposes the applied gate drive voltage, slowing down the switching speed. The isolated ground of the auxiliary supply (RTN) must be connected to this terminal if available, as in the image.

### 2.2 Why a negative voltage to turn-off the SiC-MOSFET

A half-bridge SiC-MOSFET configuration is the building block of many switching power converters (Figure 4 left), with a high-side device and a low-side device switching alternately, and each typically with its own auxiliary power supply and gate driver circuit:

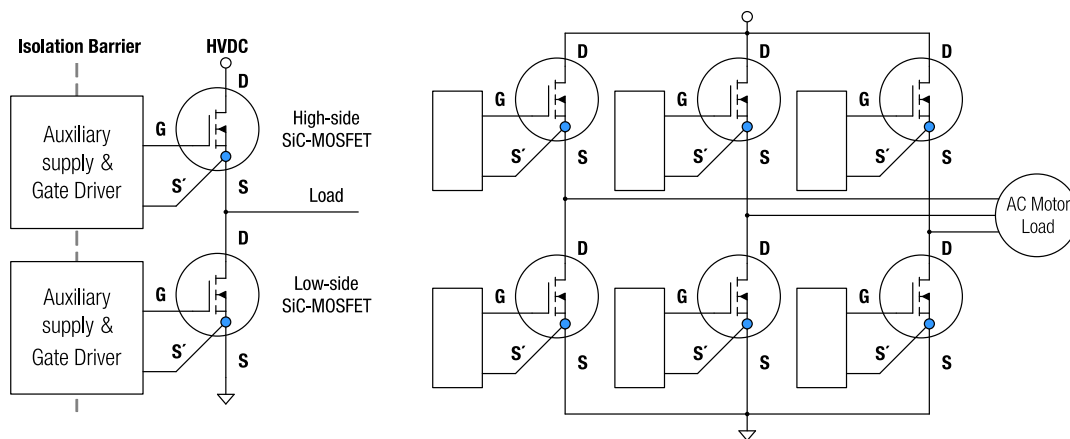

Figure 4: SiC-MOSFET half-bridge configuration (left) and 3-phase inverter application example (right)

When the high-side SiC device is turning on, the complementary low-side SiC device is already turned off as 'dead time' is used. Dead time is a short time window during switching transitions where both devices are kept off in order to prevent shoot-through or cross-conduction. This is caused by both devices being turned on at the same time due to control signal propagation delay mismatch in the gate driver, parasitic ringing, etc. During this 'dead time', the 'body-diode' of the low-side device (or an external anti-parallel diode) keeps current in the loop flowing. At turn-on of the high-side device, the very fast switching speed of SiC-MOSFETs together with the typically high application voltage causes a very high  $dV / dt$  to appear across the terminals of the low-side device (which is already off) (Figure 5). This  $dV / dt$  in turn causes an instantaneous displacement current to flow through the gate-drain capacitance  $C_{gd}$  into the gate circuit of the device. Although the gate-source impedance ( $Z_{gs}$ ) is a parallel combination of the gate-source capacitance ( $C_{gs}$ ) with the sum of the total turn-off gate resistance ( $R_g$ ) and the gate loop inductance ( $L_p$ ), for high frequency harmonics this typically approximates the impedance of  $C_{gs}$ , and therefore  $C_{gd}$  and  $C_{gs}$  form an effective capacitive divider. Based on this,  $C_{gs}$  should be considerably higher than  $C_{gd}$  in order to prevent the voltage bump generated across gate-source to exceed the threshold voltage of the device, turning it on and causing a shoot-through event. This is known as Miller-effect turn-on, with both SiC devices fully or partially on at the same time, effectively connecting the HVDC bus to GND through a low resistance path. This is a very dissipative event with consequences ranging from just a drop in efficiency and higher operating temperature up to even catastrophic damage of the devices in severe cases.

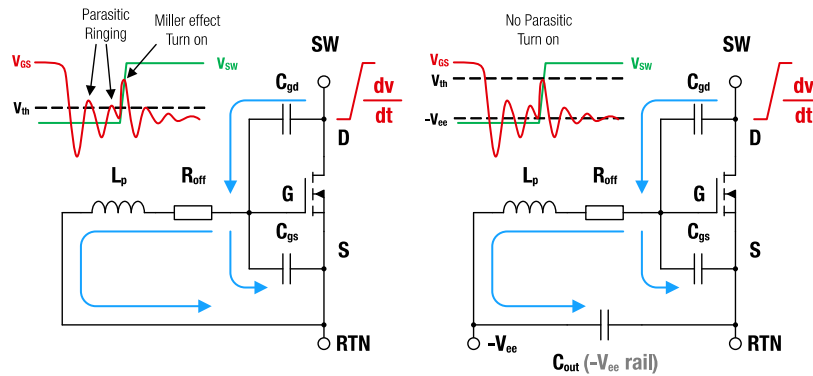

Figure 5: SiC-MOSFET Parasitic turn-on without  $-V_{ee}$  rail connection due to Miller effect and gate resonant ringing (left) and with  $-V_{ee}$  rail connection (right)

In Figure 5, an example of the Miller effect is shown for the low-side device of a half-bridge configuration, when the high-side device turns on. By holding the gate-source connection to a negative voltage, extended margin to the SiC-MOSFET turn-on threshold voltage ( $V_{th}$ ) is provided. This additional headroom can help to prevent spurious turn-on due to Miller-effect and/or parasitic ringing during the very fast switching transitions, in addition to helping to increase the switching speed. Note that there are particular cases, like in soft-switching applications or when using a gate driver IC with an active Miller clamp, where a negative voltage may not be essential.

### 2.3 Auxiliary supply: Output power requirement

During the switching transitions of the SiC-MOSFET device, power is dissipated in the gate current loop resistance as current flows to charge and discharge the gate capacitance of the device to the positive and negative auxiliary supply voltage levels, in order to turn it on and off respectively. The auxiliary supply of the gate driver system needs to source this power, which depends on the gate voltage, switching frequency and total gate charge of the SiC-MOSFET, as follows:

$$P = Q_g \cdot f_{sw} \cdot \Delta V_{gs} \quad (1)$$

where:

$Q_g$ : Total gate charge of SiC device for  $\Delta V_{gs}$  (see  $Q_g$  vs  $V_{gs}$  curve in SiC device datasheet)

$f_{sw}$ : Switching frequency of SiC device

$\Delta V_{gs}$ : Gate-to-source voltage (full-swing) (e.g. for  $V_{dd} = +15\text{ V}$  and  $V_{ee} = -4\text{ V}$ , then  $\Delta V_{gs} = 19\text{ V}$ )

# REFERENCE DESIGN

## R001 | 6 W Bipolar isolated auxiliary supply for SiC-MOSFET & IGBT gate driver

Note that the output stage circuitry of some isolated gate driver ICs is powered directly from the auxiliary supply. Its additional estimated power consumption should be added to the previously calculated gate drive power budget.

In Figure 6, it can be observed how during turn-on, the +  $V_{dd}$  rail provides the required charge ( $Q_g$ ) to the gate capacitance ( $C_g$ ), and during turn-off,  $C_g$  discharges via the -  $V_{ee}$  rail. Note that there is the same amount of charge flow to and from the gate capacitance ( $C_g$ ) in a full switching period, leading to the same average current on each rail.

For the example with  $V_{dd} = +15\text{ V}$ ,  $V_{ee} = -4\text{ V}$  and 6 W of output power provided by the auxiliary supply, the maximum average current on each rail is around 320 mA. The power contribution of each rail to the total 6 W is different: 4.8 W from the + 15 V rail and 1.2 W from the -4 V rail. Each equivalent gate resistance  $R_{on}$  and  $R_{off}$  dissipate half of the gate drive power, independent of its value (e.g. for 4 W of gate drive power, then 2 W each). Please note that  $R_{on}$  and  $R_{off}$  are not only set by external discrete resistors added, but also a contribution of parasitic resistances of the SiC device package as well as on-resistances of the push-pull transistors in the gate driver IC output stage, which in many cases are not negligible.

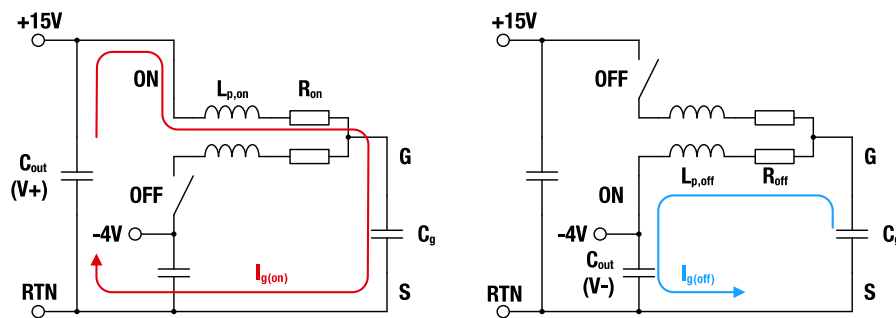

Figure 6: SiC-MOSFET main gate current loops from auxiliary supply output rails for turn-on (left) and turn-off (right)

Note also that  $R_{on}$  and  $R_{off}$  limit the gate current peak ( $I_g$ ) during each respective switching transition and in turn, adjust the switching speed of the SiC device, but their value do not affect the average gate drive power requirement. If very fast switching speed is required, the gate resistance should be reduced together with the respective loop parasitic inductance ( $L_{p,on}$  and  $L_{p,off}$ ). This will allow for higher gate drive peak current and, in turn, faster  $di/dt$ , which would speed up the switching transition.

Regarding PCB layout, it is very important to place the auxiliary supply and in particular, the output capacitors, very close to the gate driver and SiC device gate terminal in order to minimize the area of the gate current loop, and with it the parasitic inductance  $L_p$ . Multi-layer Ceramic Capacitors (MLCC) like the CSGP series from Würth Elektronik are also recommended, due to their extremely low package lead inductance  $L_c$  and ESR. The paralleling of several capacitors would allow for a higher  $di/dt$  of the gate drive current and faster switching speed due to significant reduction of total  $L_c$  and ESR. The final value and configuration of the output capacitors can be freely adjusted by the designer under consideration of switching speed of the SiC device as well as maximum voltage ripple and transient response of the auxiliary supply.

### 2.4 A critical factor in fast-switching SiC gate driver systems: Isolation Barrier Parasitic Capacitance and CMTI

CMTI is the acronym for 'Common-mode Transient Immunity', and it is measured in  $kV/\mu s$  or  $V/ns$ . It is an indication of the maximum rate of change of voltage ( $dv/dt$ ) which can be tolerated across the isolation barrier of the gate driver system before malfunction occurs, causing loss of control of the SiC device and erratic behavior of the system. The CMTI rating directly depends on the parasitic capacitance value across the isolation barrier.

Isolated gate driver ICs in the market use different techniques to transfer the control signal information across the isolation barrier (i.e. capacitive coupling, magnetic coupling, optical coupling, etc.). In the auxiliary power supply, the energy is transferred via the magnetic field using a transformer. In both cases, a parasitic capacitance exists across the isolation barrier, and in the case of the auxiliary supply, it corresponds to the transformer's interwinding capacitance. In the previous example of the half-bridge configuration, the very high  $dv/dt$  generated during the switching transition, in addition to ringing and Miller effect turn-on issues, also causes displacement currents through the isolation barrier parasitic capacitance of the high-side gate drive circuit, between the high-voltage side and the low-voltage side, where the controller and sensitive circuitry reside (Figure 7). Note that the isolated 'ground' or 'reference' of the high-side gate driver (GND\_ISO or RTN) is directly connected to the source

## REFERENCE DESIGN

### RD001 | 6 W Bipolar isolated auxiliary supply for SiC-MOSFET & IGBT gate driver

terminal of the SiC device and, in turn, to the SW node which is subject to high  $dv/dt$  transitions. Conversely, the low-voltage 'ground' or 'reference (GND)' is kept to a constant voltage (DC). The generated displacement current ( $i_c(t)$ ) across the total isolation barrier parasitic capacitance ( $C_{pt}$ ) is approximated as:

$$i_c(t) = C_{pt} \frac{dv_{ps}}{dt} \quad (2)$$

A too high displacement current may cause different issues in the system. In addition to distortion and delay of control signals, loss of control of the SiC device due to erratic behavior caused by high common-mode signals stressing the controller is also a possibility. The lower the isolation barrier parasitic capacitance, the lower the generated displacement current for a set  $dV/dt$  value. Said another way, a lower  $C_{pt}$  would allow a higher  $dV/dt$  value for the same displacement current. Higher  $dV/dt$  means faster switching speed, which in turn helps to achieve higher efficiency, a smaller overall solution size and a lower system cost of the power converter. Since a fast-switching speed is one of the key advantages of SiC devices, the parasitic capacitance across the isolation barrier (transformer interwinding capacitance and isolated gate driver IC) should be very low in such applications.

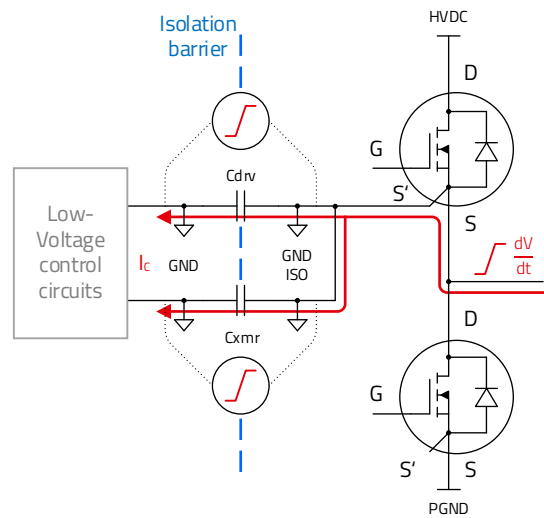

Figure 7: Displacement Currents across the isolation barrier parasitic capacitance caused by very high  $dV/dt$  in a half-bridge configuration

The **WE-AGDT** Transformer series from Würth Elektronik feature a very low interwinding capacitance down to 6.8 pF, helping the gate driver system to achieve CMTI ratings above 100 kV /  $\mu$ s.

In addition to the functional and reliability aspects, a lower isolation barrier parasitic capacitance may also help to improve EMI performance. It should be observed that the high  $dv/dt$  is not only applied between the SW node and DC nodes like DC-Power and system ground (GND) on the PCB, but it also appears between the high  $dv/dt$  conductive nodes in the circuit board and Earth potential (to which the product chassis might be connected). This generates common-mode displacement currents across the isolation barrier parasitic capacitance, adversely affecting EMI performance. The lower the parasitic capacitance  $C_{pt}$  across the isolation barrier, the higher the impedance presented to any common-mode noise currents coupling between the HV and LV sides (see Figure 8). As a result, improved EMI performance, especially in radiated emissions frequency spectrum, as well as a lower attenuation requirement for the common mode input EMI filter can be expected.

# REFERENCE DESIGN

RD001 | 6 W Bipolar isolated auxiliary supply for SiC-MOSFET & IGBT gate driver

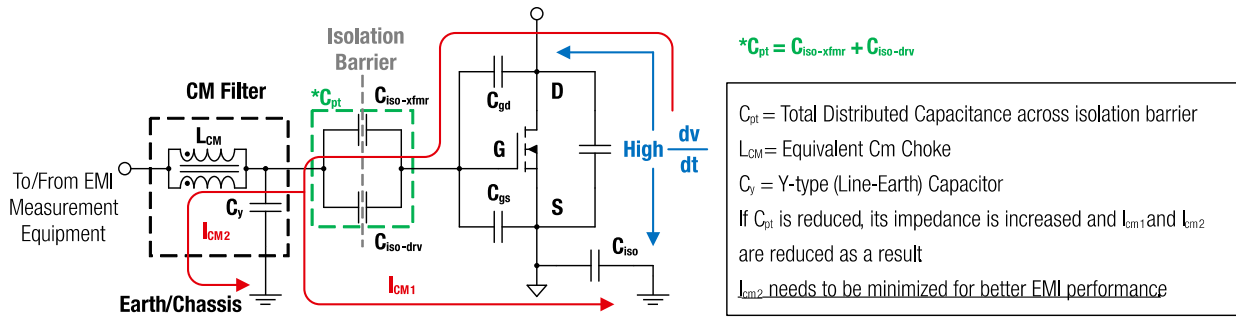

Figure 8: Simplified example of common-mode noise current coupling path for EMI considerations

For further information on SiC gate driver system considerations, please also refer to the Application note on [we-online.com/ANP082](http://www.we-online.com/ANP082).

## 03. ELECTRICAL SPECIFICATION

		Minimum	Nominal	Maximum	Units
Variant	Input Voltage	9	12	18	(V)
+15 V / -4 V	Output Voltage (+)	14.8	14.9	15.18 (*) / 15.6 (**)	(V)
	Output Voltage (-)	-3.96 (*) / -4.1 (**)	-3.85	-3.75	(V)
	Output Current (per rail)	0		320	(mA)
+19 V / -4 V	Output Voltage (+)	18.88	18.95	19.04 (*) / 19.32 (**)	(V)
	Output Voltage (-)	-4.09 (*) / -4.46 (**)	-4.05	-4	(V)
	Output Current (per rail)	0		260	(mA)
+20 V / -5 V	Output Voltage (+)	19.76	19.85	19.95 (*) / 20.84 (**)	(V)
	Output Voltage (-)	-5.15 (*) / -5.48 (**)	-5.12	-5.1	(V)
	Output Current (per rail)	0		240	(mA)
	Output Power	0		6	(W)
	Switching Frequency (**)	80		360	(kHz)

Table 1: Electrical specification table

NOTE: Specification at 25 °C ambient temperature

(\*) When adding a resistor on the isolated output for minimum-load current (for more info see section 7.3)

(\*\*) When using only the clamping Zener diode on the isolated output as per the BOM in sections 11 and 12

(\*\*\*) Switching frequency varies with load current and input voltage

# REFERENCE DESIGN

RD001 | 6 W Bipolar isolated auxiliary supply for SiC-MOSFET & IGBT gate driver

## 04.SCHEMATIC

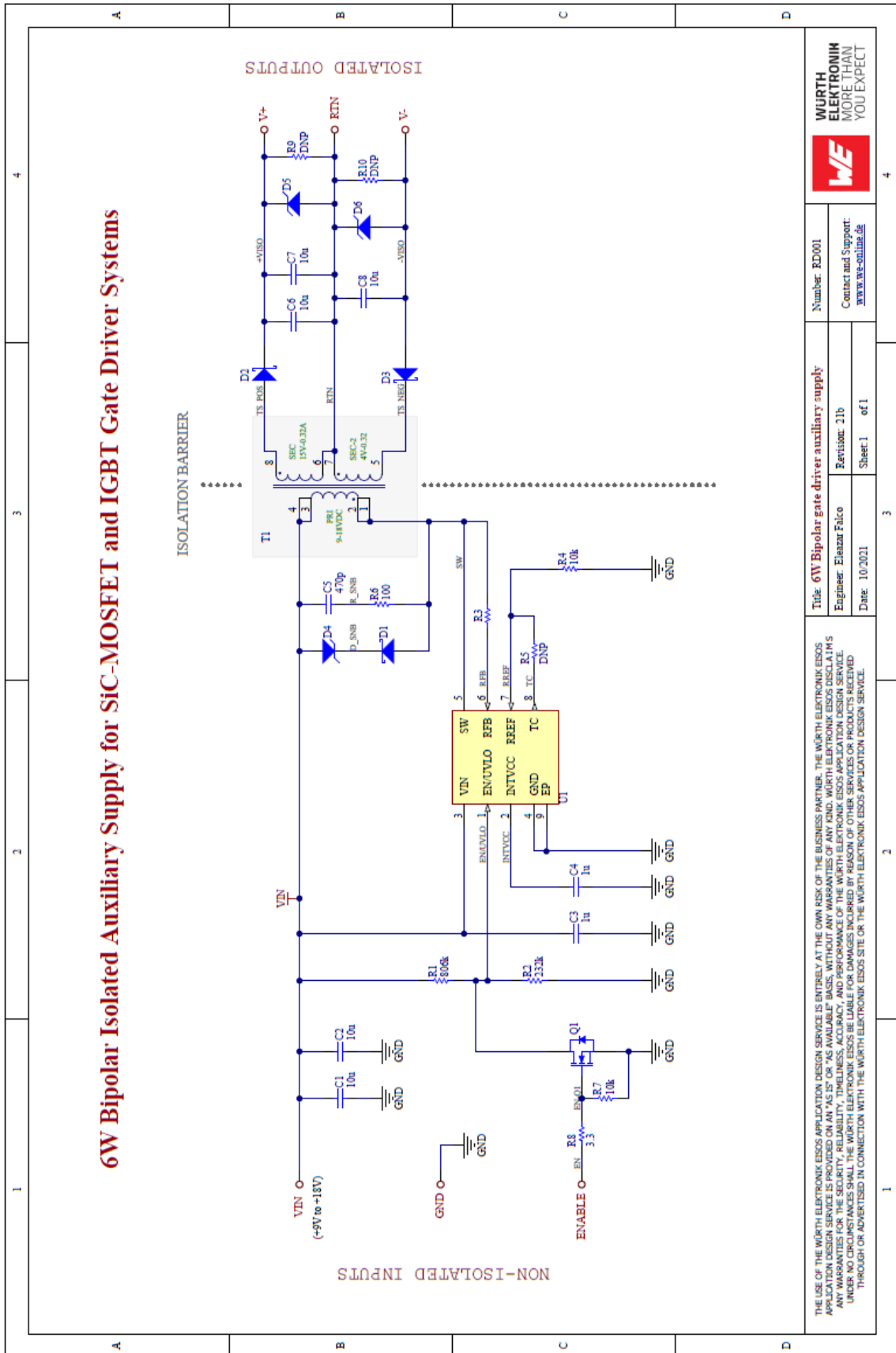

Figure 9: Schematic

## REFERENCE DESIGN

RD001 | 6 W Bipolar isolated auxiliary supply for SiC-MOSFET & IGBT gate driver

### 05. WE-AGDT DUAL-OUTPUT TRANSFORMER SERIES

Würth Elektronik has designed a new transformer series featuring optimal characteristics to be used in this PSR Flyback converter reference design to drive high-performance SiC-MOSFET devices, providing the most commonly required gate drive voltages.

Finding an optimal converter operating condition to achieve the smallest transformer size and at the same time high efficiency, good thermal performance and compliance with relevant safety standards were the key design objectives. The WE-AGDT [750318131](#), [750319496](#) and [750319497](#) transformers use a very compact EP7 assembly, 4 kV isolation voltage, overvoltage category II, pollution degree 2, fully insulated wire (FIW) and creepage/clearance distances according to standards IEC62368-1 and IEC61558-2-16. Additionally, it counts with AEC-Q200 qualification.

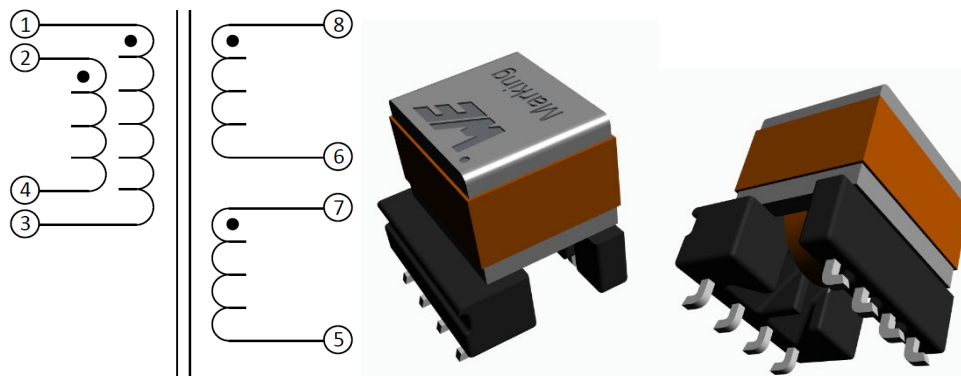

Figure 10: **WE-AGDT** Dual-output Transformer details

Parameter	Test conditions	WE-AGDT <a href="#">750318131</a>	WE-AGDT <a href="#">750319496</a>	WE-AGDT <a href="#">750319497</a>
DC resistance – primary	tie(1+2, 3+4), +20 °C	0.047 Ω ± 15%	0.042 Ω ± 15%	0.042 Ω ± 15%
DC resistance – Sec.1	(8-6), +20 °C	0.205 Ω ± 15%	0.370 Ω ± 10%	0.350 Ω ± 10%
DC resistance – Sec.2	(7-5), +20 °C	0.071 Ω ± 15%	0.115 Ω ± 15%	0.095 Ω ± 15%
Magnetizing inductance	10 kHz, 100 mV	7.00 μH ± 10%	7.00 μH ± 10%	7.00 μH ± 10%
Saturation current	20% roll-off of L <sub>mag</sub>	4.5 A (min.)		
Leakage inductance	100 kHz, 100 mV	270 nH (typ.)	275 nH (typ.)	245 nH (typ.)
Interwinding capacitance	100 kHz, 10 mVAC	7.5 pF (typ.)	7.3 pF (typ.)	7.5 pF (typ.)
Dielectric	4000 VAC, 1 second	4000 VAC, 1 minute		
Partial discharge	1000 V <sub>rms</sub> , 5 sec. 800 V <sub>rms</sub> 15 sec.	<10 pC		
Turns ratio	(1-3):(2:4)	1:1 (±1%)		
Turns ratio	(8-6):(1:3)	1.55:1 (±1%)	2:1 (± 1%)	1.89:1 (± 1%)
Turns ratio	(1-3):(7:5)	2.2:1 (±1%)	1.8:1 (± 1%)	2.25:1 (± 1%)
Temperature range		-40 °C / +130 °C		

Table 2: WE-AGDT [750318131](#), [750319496](#) and [750319497](#) transformer characteristics

### 06. BOARD LAYOUT VARIANTS

This reference design is provided in two layout variants: a two-layer single-sided and a four-layer double-sided solution, as well as with two component assembly options: Standard and with AEC-Q qualified components.

# REFERENCE DESIGN

RD001 | 6 W Bipolar isolated auxiliary supply for SiC-MOSFET & IGBT gate driver

## 6.1 Board layout variant A: Double-sided design

This variant is a four-layer design with all-SMD (surface mount) component assembly on top and bottom sides.

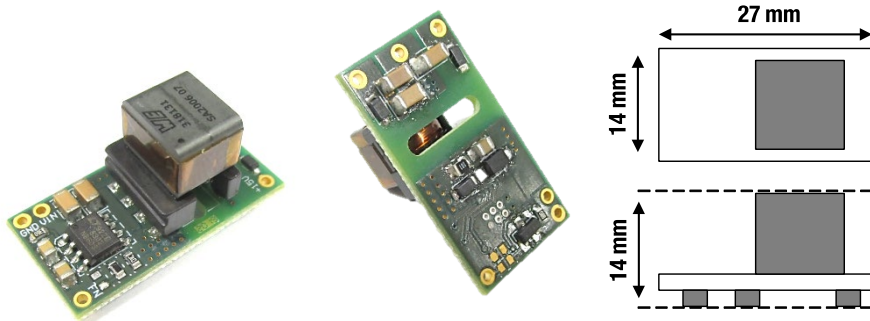

Figure 11: Board variant-A (a) top view (b) bottom view (c) dimensions

## 6.2 Board layout variant B: Single-sided design

This variant is a two-layer design with all-SMD (surface mount) component assembly only on top side.

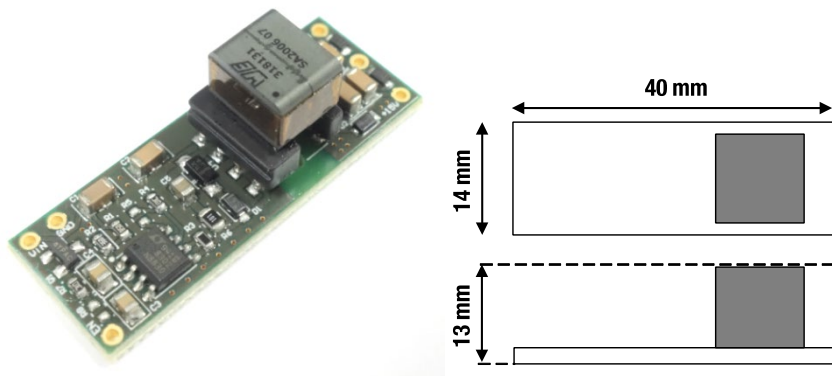

Figure 12: Board variant-B detail and dimensions overview

NOTE: No significant performance difference has been observed or can be expected between the two board layout variants, be this functional, thermal or regarding EMC behaviour. The selection of the variant to use can therefore be made based only on the particular constraints of the application. The compact layout lends itself optimally to integration onto a larger board together with the full gate driver system.

The PCB Layout design files (Altium Designer 21) as well as the fabrication files are available to download on [we-online.com/RD001](https://www.we-online.com/RD001).

## 07. EXPERIMENTAL RESULTS

### 7.1 Experimental test setup

The power supply has been tested for functional performance using two electronic loads configured in constant-current (CC) mode. Alternatively, resistive-mode of electronic load or discrete power resistors drawing balanced current on both rails can also be used. Tests are carried out at 25 °C ambient temperature.

#### 7.1.1 List of equipment required (and used in this case)

- 1 × Laboratory power supply (min. 25 V/1.5 A) (used EA-PSI 9040-40 T)
- 4 × 4-digit precision multimeter (it was used instead a Yokogawa WT3000E precision power analyzer)
- 2 × electronic loads (25 V/1 A min.) (used EA-EL 9080-45 T)
- 1 × oscilloscope (4 channel, 350 MHz or higher) (used Keysight InfiniiVision DSO-X-3034T)

# REFERENCE DESIGN

## R001 | 6 W Bipolar isolated auxiliary supply for SiC-MOSFET & IGBT gate driver

NOTE: A precision power analyzer (min. 3-channel) can be used as an alternative to the four multimeters for highly-accurate voltage and current measurements.

### 7.1.2 System setup

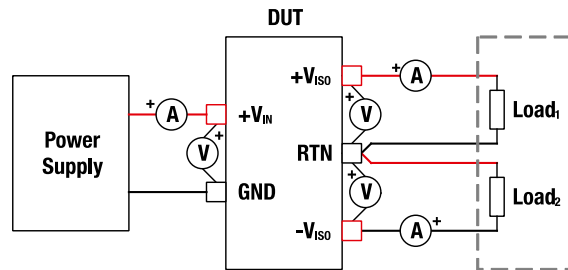

Figure 13: Example of test setup configuration

NOTE: When testing the power supply as described here, both channels must be loaded with the same average current (balanced load). This current emulates the charge flow per second between the gate capacitance of the SiC-MOSFET and the respective output rail when switching. The average current will increase with switching frequency and SiC-MOSFET total gate charge (i.e. capacitance).

### 7.2 Output voltage regulation under load

The line and load regulation results show how the output voltage varies with variations in both the input voltage and output power, respectively.

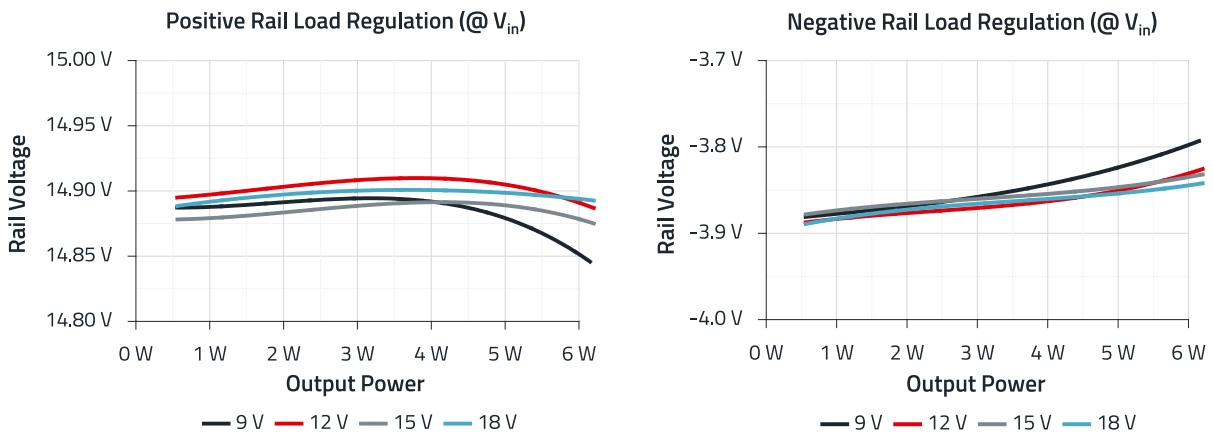

Figure 14: Load and line regulation for  $V_{out} = +15V / -4V$  variant

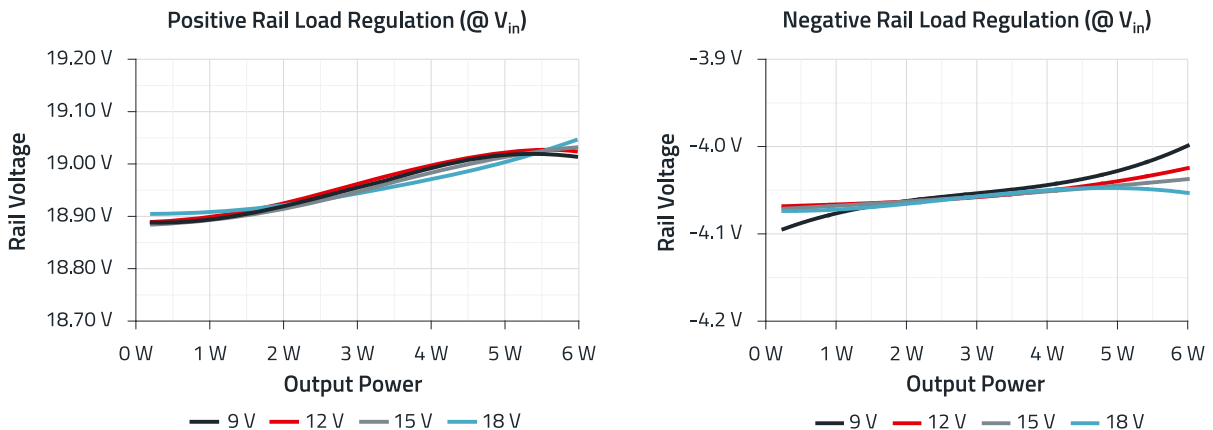

Figure 15: Load and line regulation for  $V_{out} = +19V / -4V$  variant ( $V_{in} = 9V, 12V, 15V, 18V$ )

# REFERENCE DESIGN

RD001 | 6 W Bipolar isolated auxiliary supply for SiC-MOSFET & IGBT gate driver

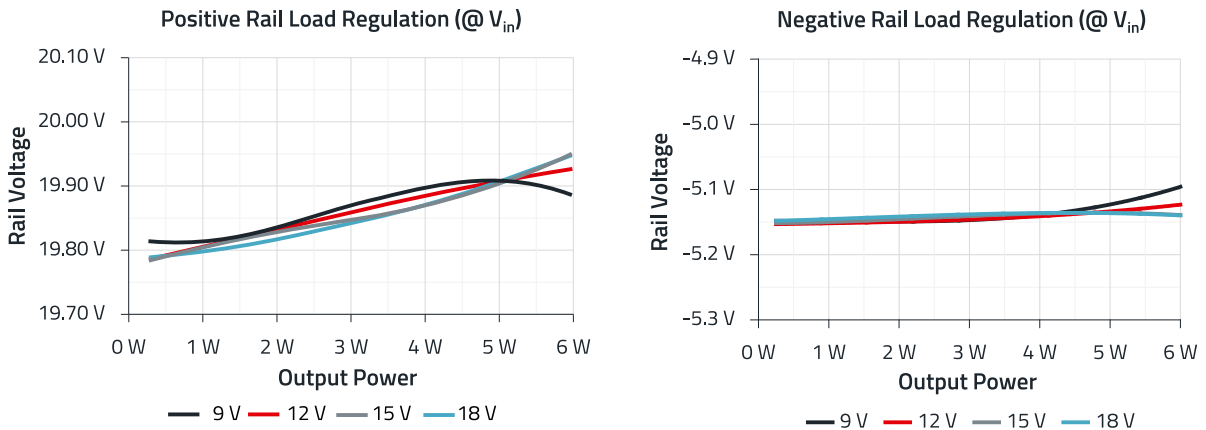

Figure 16: Load and line regulation for  $V_{out} = +20\text{ V} / -5\text{ V}$  variant ( $V_{in} = 9\text{ V}, 12\text{ V}, 15\text{ V}, 18\text{ V}$ )

### 7.3 Output voltage regulation at no-load

The LT8302 IC controller requires a minimum load current in order to keep the output voltage regulated, preventing it from steadily increasing at no-load condition. No-load would be the scenario presented when the SiC-MOSFET or IGBT device is not switching. This requirement can be met by using a minimum-load resistor on each isolated output or alternatively only clamping Zener diodes.

	Variant		
	15 V / -4 V	19 V / -4 V	20 V / -5 V
Resistors (*)	15.18 V / -3.96 V	19.04 V / -4.09 V	19.95 V / -5.15 V
Zener Diodes (*) (**)	15.6 V / -4.1 V	19.32 V / -4.46 V	20.84 V / -5.48 V

Table 3: Output voltage at no-load condition with minimum-load resistor or with Zener diode only

(\*) See sections 10 and 11 (BoM variants) for details of the parts used in each case

(\*\*) The Zener diode is already included in the design for overvoltage protection, but it can additionally sink the minimum load current to clamp  $V_{out}$

### 7.4 Power Efficiency

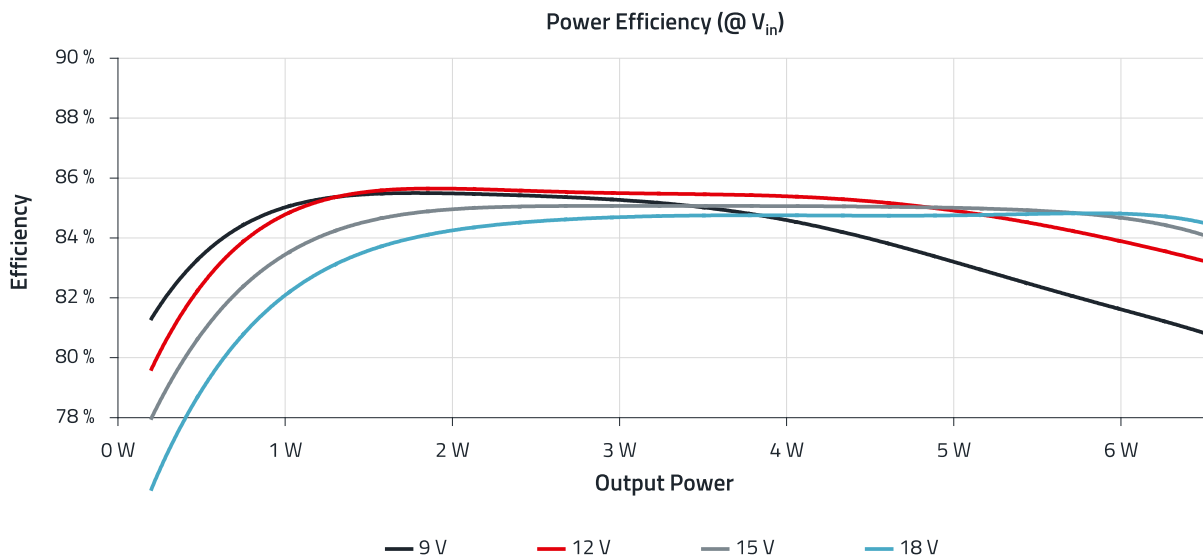

Figure 17: Power Efficiency for  $V_{out} = +15\text{ V} / -4\text{ V}$

# REFERENCE DESIGN

RD001 | 6 W Bipolar isolated auxiliary supply for SiC-MOSFET & IGBT gate driver

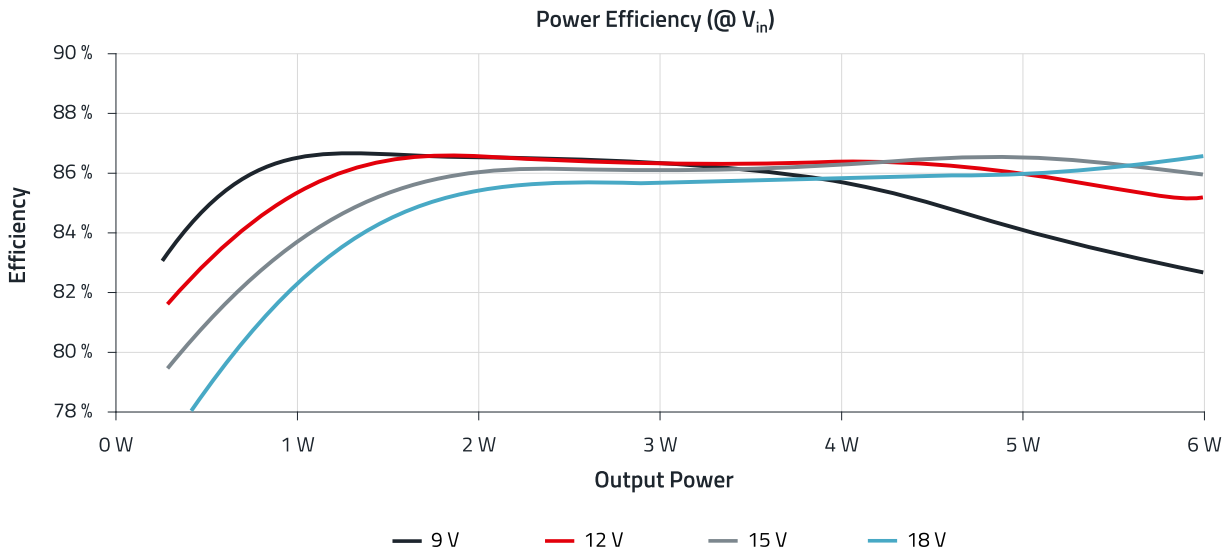

Figure 18: Power Efficiency for  $V_{out} = +19\text{ V} / -5\text{ V}$

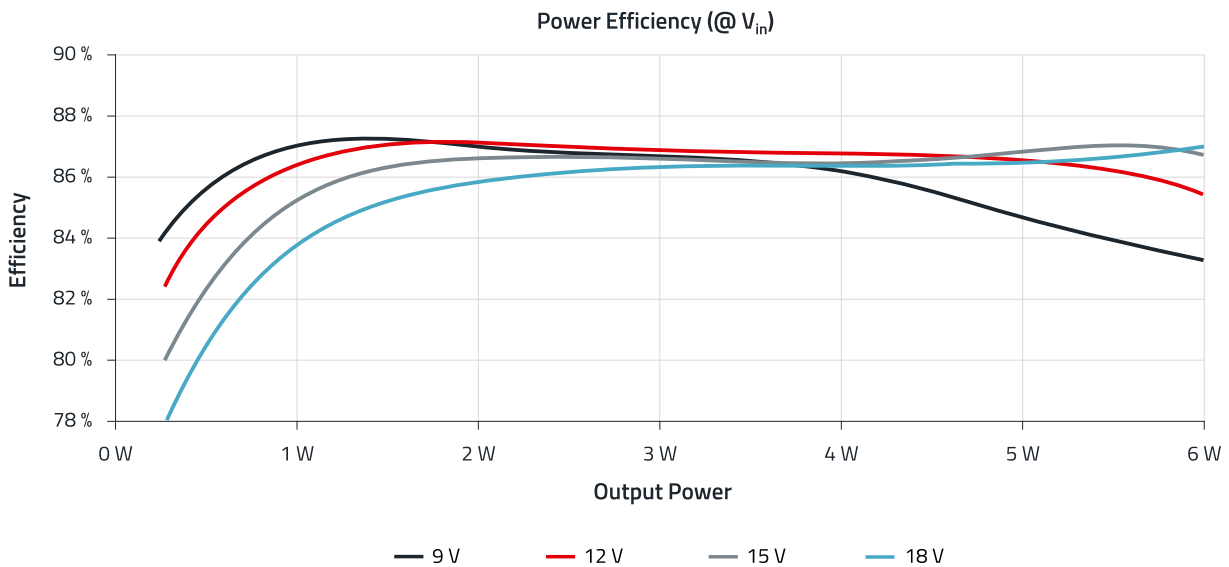

Figure 19: Power Efficiency for  $V_{out} = +20\text{ V} / -5\text{ V}$

## 08. MAIN WAVEFORMS, OSCILLOSCOPE CAPTURES

In this section experimental results of the variant  $V_{out} = +15\text{ V} / -4\text{ V}$  are shown. For the variants with  $V_{out} = +19\text{ V} / -4\text{ V}$  and  $V_{out} = +20\text{ V} / -5\text{ V}$  the measured results are very similar and therefore not included here.

### 8.1 Start-up and shut-down (@ full-load)

The start-up event shows no overshoot or ringing of the positive and negative output voltage rails (Figure 20). During the shut-down event, the input capacitance supplies the energy until the voltage falls below the UVLO threshold and the controller stops switching, after which the output capacitance delivers the remaining stored energy and the output voltage falls to zero in about 1 ms (Figure 21). Note that the slowly rising slope of the input voltage is due to the soft-start of the laboratory power supply used.

# REFERENCE DESIGN

RD001 | 6 W Bipolar isolated auxiliary supply for SiC-MOSFET & IGBT gate driver



Figure 20: Start-up at full-load



Figure 21: Shut-down at full-load

## 8.2 Steady-state operation

### 8.2.1 Operation mode with load power

Below are shown the transformer primary current and SW node voltage waveforms for 1 W and 6 W loads. At light load, the Flyback auxiliary supply will operate in discontinuous conduction mode (DCM) (Figure 22), whereas as the output power increases, the dynamic peak current limit increases accordingly eventually reaching boundary conduction mode operation (BCM) (Figure 23). Note that the converter does not operate in continuous conduction mode (CCM), since the current needs to fall to zero each cycle in order for the IC controller to sample and regulate the output voltage.

## REFERENCE DESIGN

RD001 | 6 W Bipolar isolated auxiliary supply for SiC-MOSFET & IGBT gate driver



Figure 22: 1 W load (DCM operation)

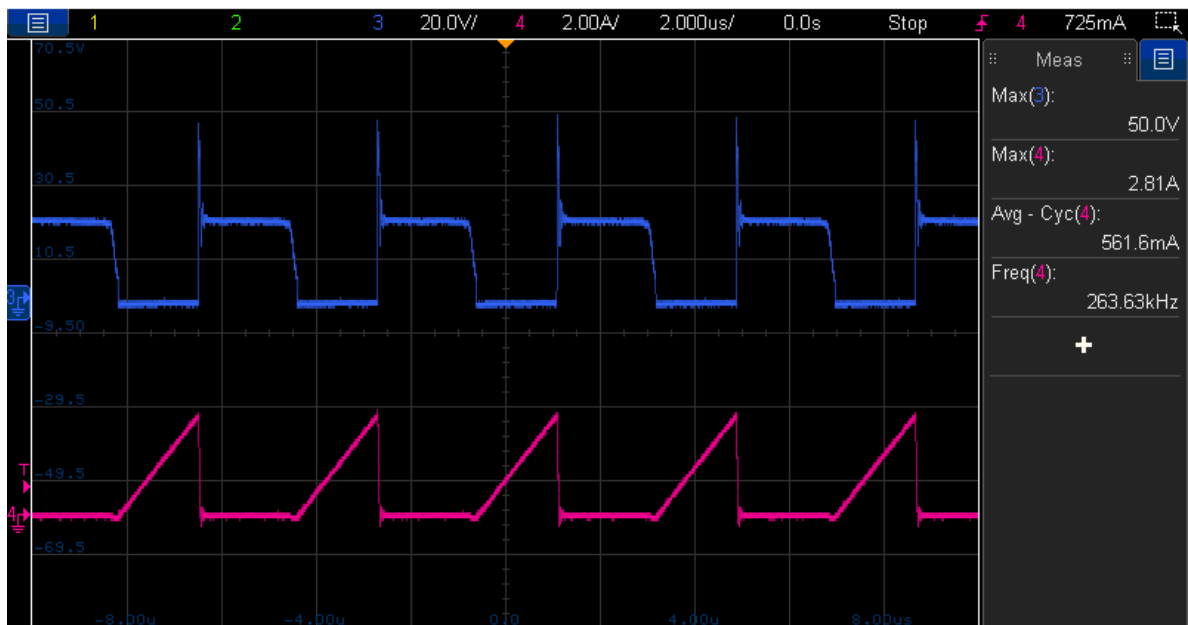

Figure 23: Full load (6 W) (BCM operation)

# REFERENCE DESIGN

RD001 | 6 W Bipolar isolated auxiliary supply for SiC-MOSFET & IGBT gate driver

## 8.2.2 SW node clamping and damping snubbers

The SW node voltage must be kept under 65 V (LT8302 integrated MOSFET rating) and any ringing appearing after the MOSFET turns OFF must be fully damped before 250 ns after the switching event in order for the LT8302 to correctly sample and regulate the output voltage. The worst-case condition for maximum peak voltage clamping is at the maximum input voltage (18 V) and full-load (6 W) (Figure 24). Regarding ringing damping, the worst-case corresponds to the minimum input voltage (9 V) and also full-load (6 W) (Figure 25). Oscilloscope captures below under full-load (6 W) show maximum SW node voltage of 54.9 V and ringing fully damped before 200 ns, which not only meets the requirements, but also provides additional headroom to account for the impact of part-to-part tolerances and operating temperature deviations.



Figure 24: SW Node voltage clamping ( $V_{in} = 18\text{ V}$ ,  $P = 6\text{ W}$ )

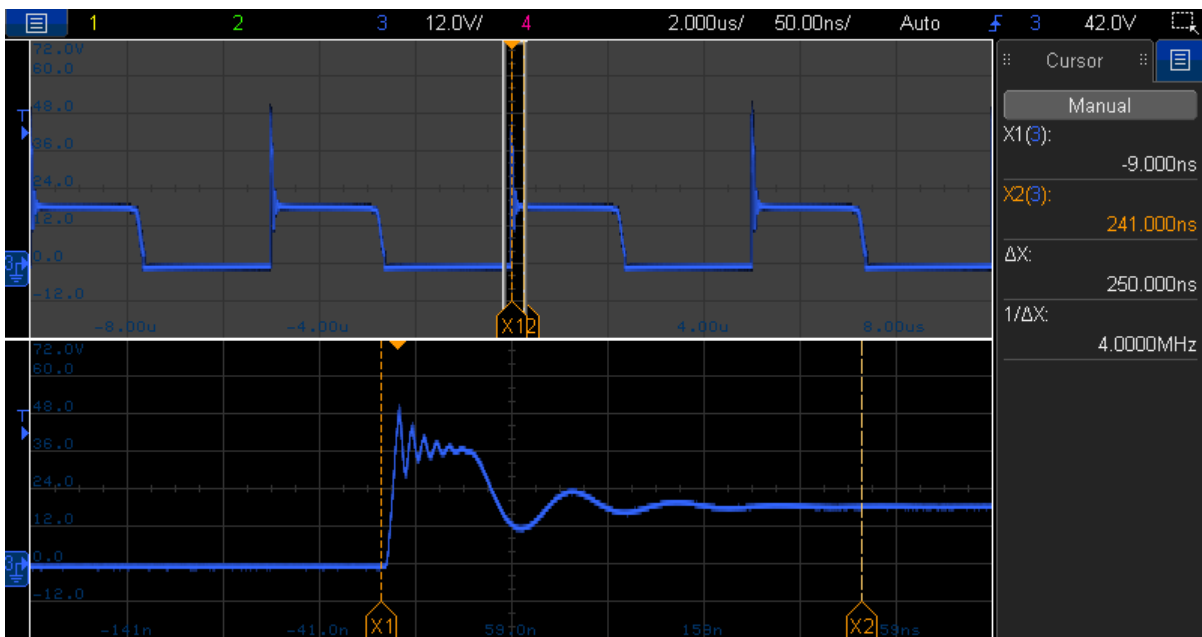

Figure 25: SW Node ringing damping ( $V_{in} = 9\text{ V}$ ,  $P = 6\text{ W}$ )

## REFERENCE DESIGN

RD001 | 6 W Bipolar isolated auxiliary supply for SiC-MOSFET & IGBT gate driver

### 8.2.3 Input and output voltage ripple (at full load)

An input voltage ripple amplitude of around 200 mV (peak-to-peak) is observed, which corresponds to less than 2% of the nominal input voltage (Figure 26). The output voltage ripple amplitude on the positive and negative rail is 125 mV and 92 mV, respectively. Additional capacitance can be added to the input or output rails in order to reduce the ripple amplitude if desired.

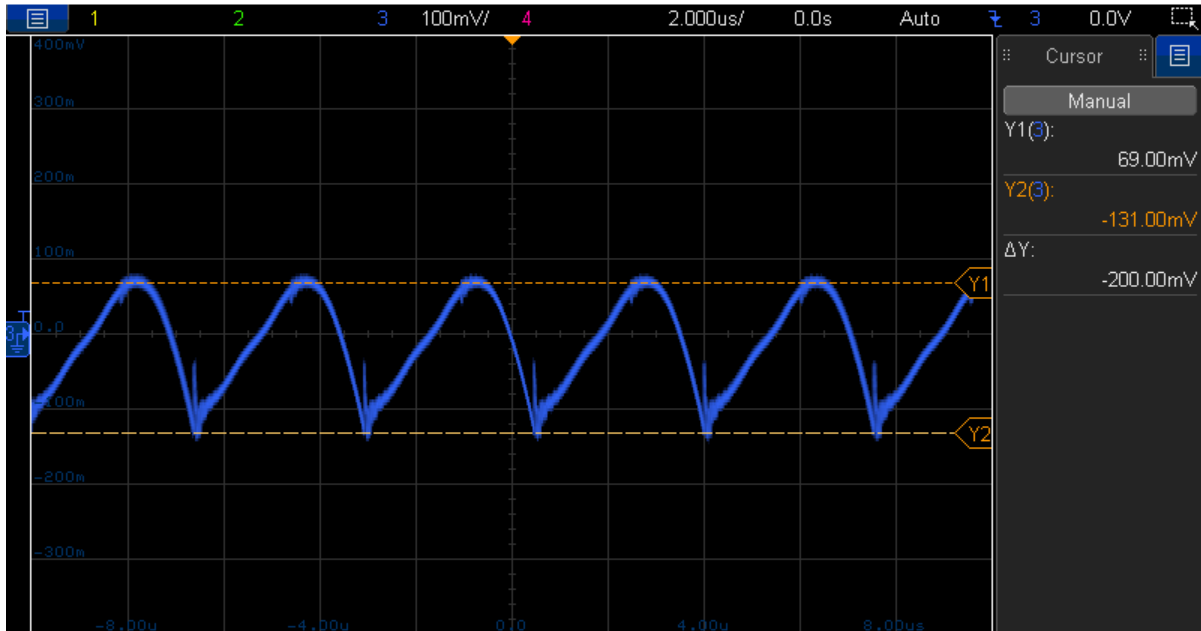

Figure 26:  $\Delta V_{in}$  (12  $V_{in}$ , 6 W) (AC-coupled)

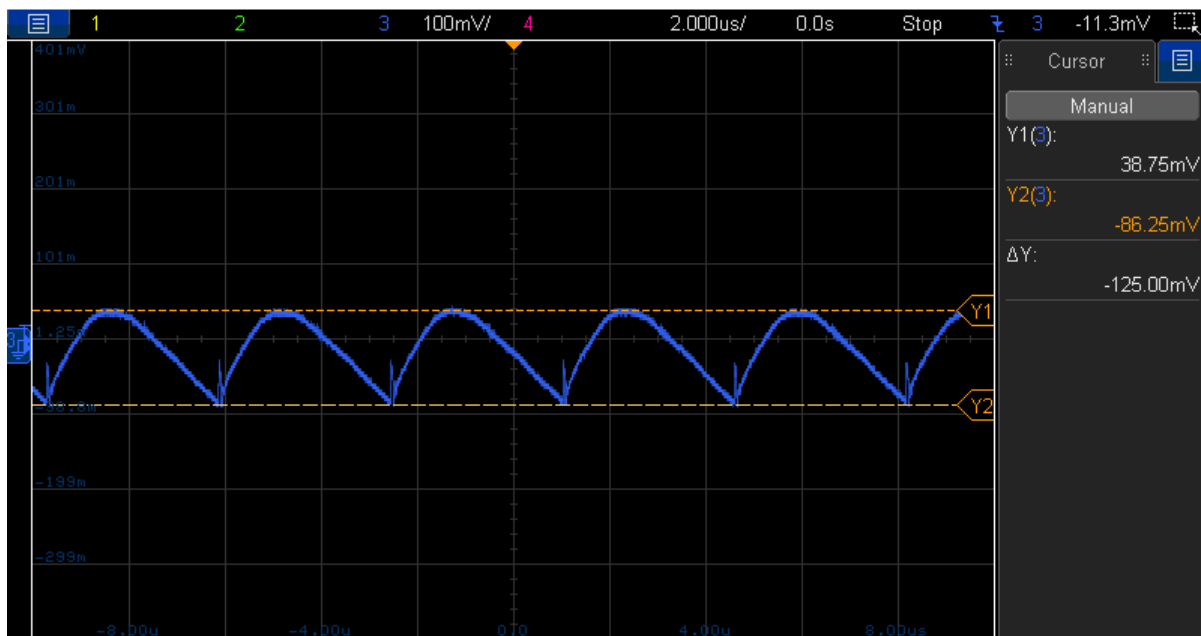

Figure 27:  $\Delta V_{out}$  Positive rail (12  $V_{in}$ , 6 W) (AC-coupled)

# REFERENCE DESIGN

RD001 | 6 W Bipolar isolated auxiliary supply for SiC-MOSFET & IGBT gate driver

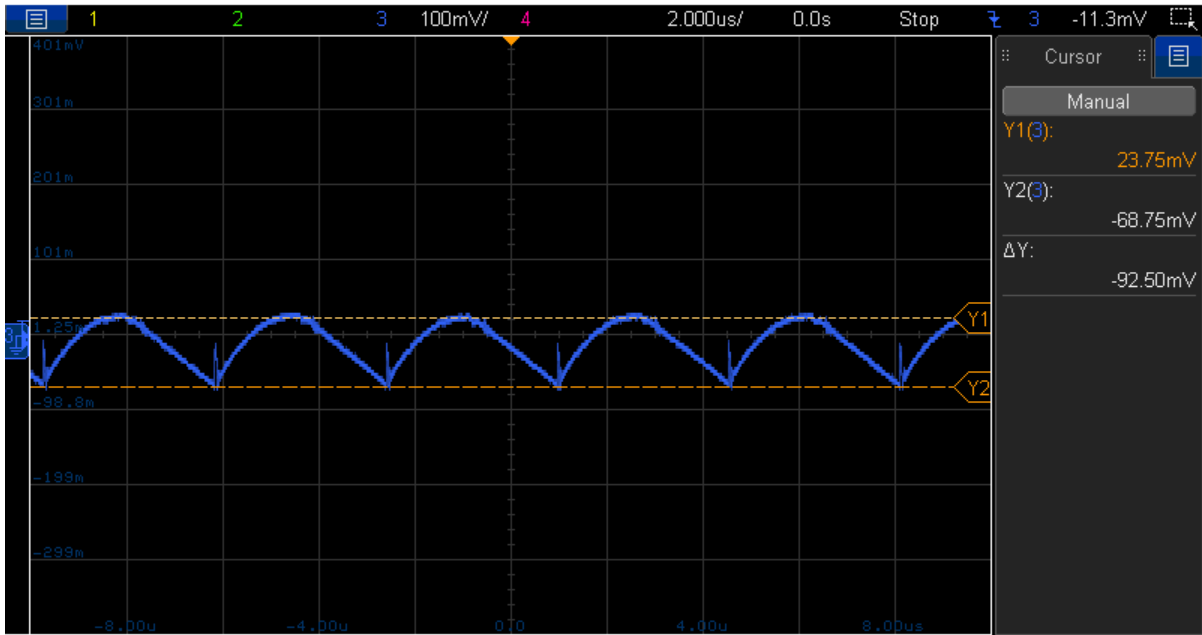

Figure 28:  $\Delta V_{out}$  Negative rail ( $12 V_{in}$ , 6 W) (AC-coupled)

### 8.2.4 Load short-circuit and Over-current protection

An overload condition would represent a scenario of a fault in the system, which can be caused, for instance, by the SiC-MOSFET device failing short-circuit across gate and source. This would present a continuous resistive load to the auxiliary supply (instead of mostly capacitive as in normal operation) corresponding to the equivalent gate loop resistance. But since this resistance is typically of very low value, it will draw high current from the auxiliary supply. In this situation, the LT8302 controller will enter hiccup short-circuit protection mode, limiting maximum peak currents. Experimental results under this fault condition show maximum peak current limited to 4.65 A (LT8302 limit), and maximum switch voltage peaking at 62 V, both within ratings of **WE-AGDT** transformer and LT8302 integrated MOSFET. This improves reliability and robustness of the application as additional upstream damage to the gate driver auxiliary supply can be prevented even under a fault in the main power converter.



Figure 29: Short-circuit protection at  $V_{in} = 18 V$

# REFERENCE DESIGN

RD001 | 6 W Bipolar isolated auxiliary supply for SiC-MOSFET & IGBT gate driver

## 09.THERMAL PERFORMANCE

Thermal performance results over the full-load range (0.1 to 6 W) at minimum input voltage ( $V_{in} = 9\text{ V}$ ) are shown in this section. The results correspond to layout variant-B board. Note that the thermal performance of PCB layout variant A and the other output voltage variants did not show important differences (i.e. more than 5 °C temperature variations).

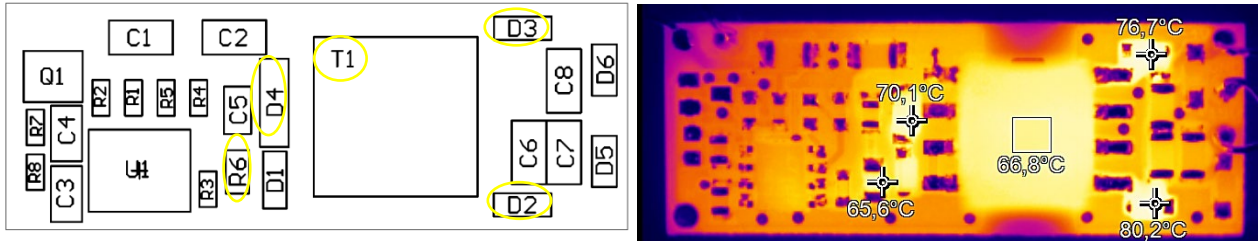

Figure 30: Board components temperature at  $V_{in} (min) = 9\text{ V}$  (worst-case) and 25 °C ambient for + 15 V / - 4 V variant

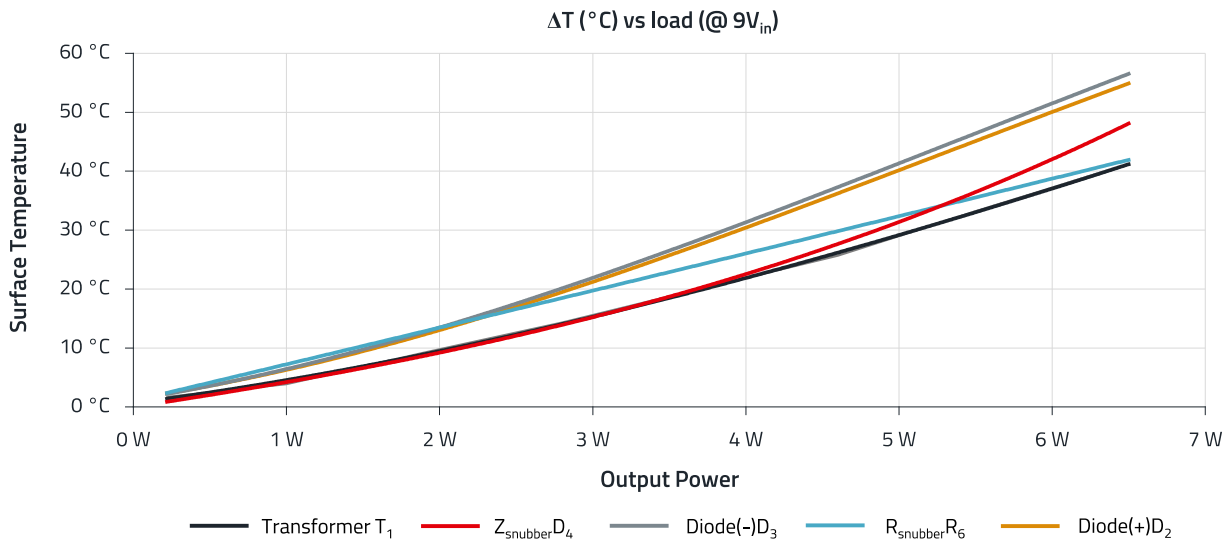

Figure 31: Temperature rise at  $V_{in} (min) = 9\text{ V}$  (worst-case) for + 15 V / - 4 V variant

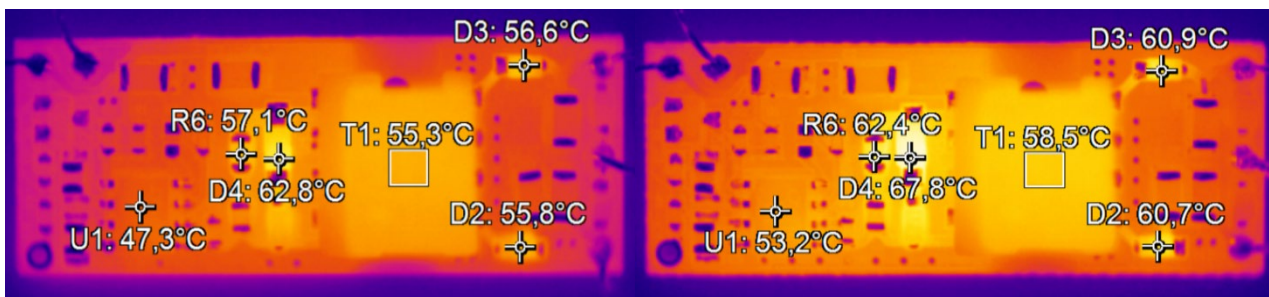

Figure 32: Board components temperature at  $V_{in} (min) = 9\text{ V}$  and 6 W (worst-case) with 25 °C ambient for + 19 V / - 4 V (left) and + 20 V / - 5 V (right)

Based on the above results, in order to keep internal/junction component temperatures within maximum ratings, it is recommended not to exceed a maximum ambient temperature of 80 °C (max) for + 15 V / - 4 V variant and 90 °C (max) for + 19 V / - 4 V and + 20 V / - 5 V variants for longer lifetime and higher reliability of the application.

If the noted ambient temperature is exceeded, the output power must be reduced (de-rated) accordingly.

# REFERENCE DESIGN

RD001 | 6 W Bipolar isolated auxiliary supply for SiC-MOSFET & IGBT gate driver

## 10. EMC PERFORMANCE

EMC test results based on CISPR32-Class B limits are shown below for board variant-A and  $V_{out} = +15\text{ V} / -4\text{ V}$ . An input LC filter and a 10 cm x 10 cm copper plane connected to input GND equivalent to chassis as detailed below were added to pass the test. Operating conditions are  $V_{in} = 12\text{ V}$  with 6 W output resistive load (330 mA current draw per rail).

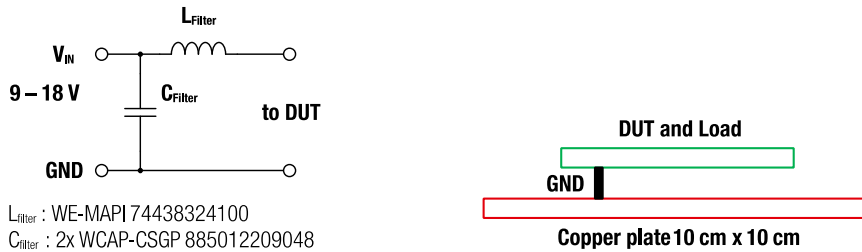

Figure 33: LC filter and copper plane added to pass CE and RE CISPR-32B EMC tests

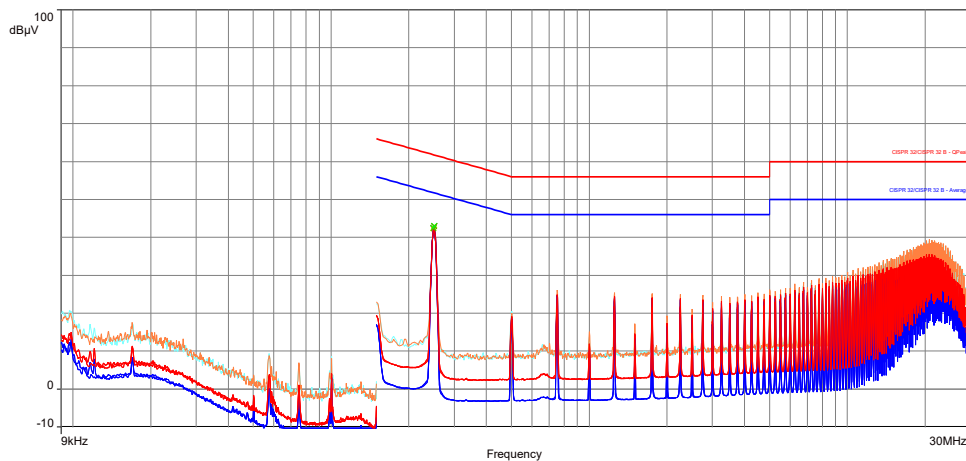

Figure 34: Conducted emissions results (CISPR32 Class B limits)

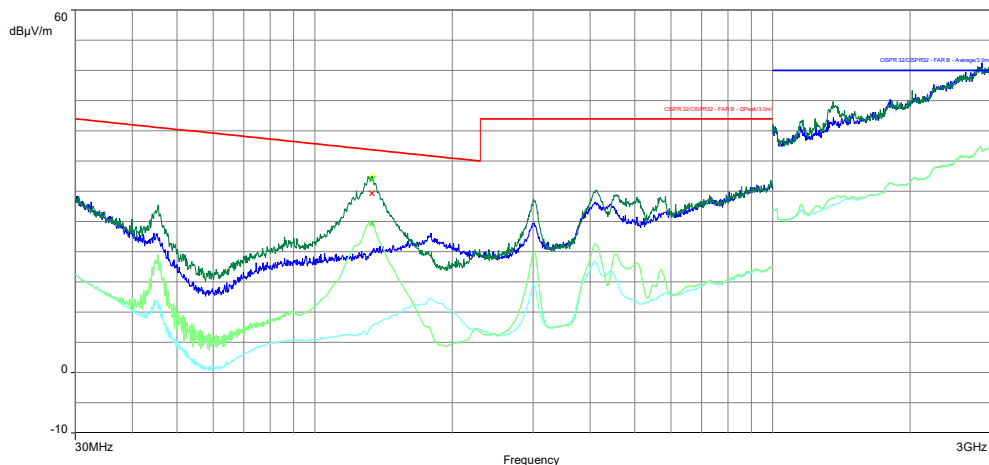

Figure 35: Radiated emissions results (CISPR32 Class B limits) (30 cm length input cables)

## REFERENCE DESIGN

RDO01 | 6 W Bipolar isolated auxiliary supply for SiC-MOSFET & IGBT gate driver

### 11. BILL-OF-MATERIALS (BoM) OPTION 1: STANDARD

Bill-of-materials for the + 15 V / - 4 V variant is shown in Table 4. The component variations for the + 19 V / - 4 V and + 20 V / - 5 V variants are shown below.

Reference designator	Description	Package	Manufacturer	MPN
C1, C2, C6, C7, C8	MLCC 10 uF 50 V X5R 10%	1206	Würth Elektronik	<a href="#">885012108022</a>
C3, C4	MLCC 1 uF 50 V X7R 10%	0805	Würth Elektronik	<a href="#">885012207103</a>
C5	MLCC 470 pF 50 V X7R 10%	0805	Würth Elektronik	<a href="#">885012207084</a>
D1, D2, D3	Schottky Rectifier 1 A, 100 V	μSMP	Vishay	V1PM10-M3/H
D4	Zener 27 V, 0.5 W	μSMF	Vishay	BZD27C27P-M3
D5 (*)	Zener 15.25-16.04 V, 0.5 W	μSMF	Vishay	PLZ16B-G3/H
D6 (*)	Zener 4.55-4.80 V, 0.5 W	μSMF	Vishay	PLZ4V7B-G3/H
R1	Thick Film, 806 k, 0.1 W, 1%	0603	Yageo	RC0603FR-07806KL
R2	Thick Film, 232 k, 0.1 W, 1%	0603	Yageo	RC0603FR-07232KL
R3 (*)	Thin Film, 93.1 k, 0.1 W, 0.1%	0603	Yageo	RT0603BRD0793K1L
R4	Thin Film, 10 k, 0.1 W, 0.1%	0603	Yageo	RT0603BRD0710KL
R5 (DNP)	N/A	0603	N/A	N/A
R6	Thick Film, 100, 0.5 W, 5%	0805	Bourns	CMP0805-FX-1000ELF
R7	Thick Film, 10 k, 0.1 W, 1%	0603	Yageo	RC0603FR-0710KL
R8	Thick Film, 3.3, 0.1 W, 1%	0603	Yageo	RC0603FR-073R3L
R9 (*) (opt)	Thick Film, 10 k, 0.2 W, 1%	0603	Yageo	RC0603FR-7W10KL
R10 (*) (opt)	Thick Film, 2.2 k, 0.1 W, 1%	0603	Yageo	RC0603FR-072K2P
Q1	MOSFET N-Channel, 40 V	SOT23-3	Vishay	SQ2318AES-T1_BE3
U1	PSR Flyback Controller 65 V 4.5 A	SO-8	Analog Devices	LT8302HS8E#PBF
T1 (*)	Transformer 7 uH, 4.5 A, 7.5 pF AEC-Q200	EP-7	Würth Elektronik	<a href="#">750318131</a>

Table 4: Bill-of-Materials (BoM) for  $V_{out} = + 15 V / - 4 V$  variant. Option 1: Standard

(\*) For  $V_{out} = + 19 V / - 4 V$  variant, use:

D5	Zener 19.23-20.22 V, 0.5 W	μSMF	Vishay	PLZ20C-G3/H
D6	Zener 4.30-4.57 V, 0.5 W	μSMF	Vishay	PLZ4V3C-G3/H
R3	Thin Film, 95.3k, 0.1 W, 0.1%	0603	Yageo	RT0603BRD0795K3L
R9 (opt)	Thick Film, 13k, 0.25 W, 5%	0603	Panasonic	ERJ-S03F1302V
R10 (opt)	Thick Film, 2.2k, 0.1 W, 1%	0603	Yageo	RC0603FR-102K2L
T1	Transformer 7uH, 4.5A, 7.5pF AEC-Q200	EP-7	Würth Elektronik	<a href="#">750319497</a>

Table 5: Component variation for  $V_{out} = + 19 V / - 4 V$  variant. Option 1: Standard

(\*) For  $V_{out} = + 20 V / - 5 V$  variant, use:

## REFERENCE DESIGN

RD001 | 6 W Bipolar isolated auxiliary supply for SiC-MOSFET & IGBT gate driver

D5	Zener 20.15-21.20 V, 0.5 W	μSMF	Vishay	PLZ22A-G3/H
D6	Zener 5.45-5.63 V, 0.5 W	μSMF	Vishay	PLZ5V6B-G3/H
R3	Thin Film, 94.2 k, 0.1 W, 0.1%	0603	Yageo	RT0603BRD0794K2L
R9 (opt)	Thick Film, 18 k, 0.1 W, 1%	0603	Panasonic	ERJ-S03F1802V
R10 (opt)	Thick Film, 3.3 k, 0.1 W, 1%	0603	Panasonic	ERJ-3EKF3301V
T1	Transformer 7 uH, 4.5 A, 7.5 pF AEC-Q200	EP-7	Würth Elektronik	<b>750319496</b>

Table 6: Component variation for  $V_{out} = +20\text{ V} / -5\text{ V}$  variant. Option 1: Standard

## 12. BILL-OF-MATERIALS (BoM) OPTION 2: AEC-Q QUALIFIED COMPONENTS

Bill-of-materials for the + 15 V / - 4 V variant is shown in Table 7. The component variations for the + 19 V / - 4 V and + 20 V / - 5 V variants are shown below.

Reference designator	Description	Package	Manufacturer	MPN
C1, C2, C6, C7, C8	MLCC 10 uF 50 V X5R 10% AEC-Q200	1206	Murata	GRT31CR61H106KE01L
C3, C4	MLCC 1 uF 50 V CGJ 10% AEC-Q200	0805	TDK	CGJ4J3X7R1H105K125AB
C5	MLCC 470 pF 50 V X7R 10% AEC-Q200	0805	Kemet	C0805S471K5RACAUTO
D1, D2, D3	Schottky Rectifier 1 A, 100 V AEC-Q101	μSMP	Vishay	V1PM10HM3
D4	Zener 27 V, 0.5 W, AEC-Q101	μSMF	Vishay	BZD27C27P-HE3
D5 (*)	Zener 15.25-16.04 V, 0.5 W	μSMF	Vishay	PLZ16B-HG3/H
D6 (*)	Zener 4.55-4.80 V, 0.5 W	μSMF	Vishay	PLZ4V7B-HG3/H
R1	Thick Film, 806 k, 0.1 W, 1%, AEC-Q101	0603	Yageo	AC0603FR-07806KL
R2	Thick Film, 232 k, 0.1 W, 1%, AEC-Q101	0603	Yageo	AC0603FR-07232KL
R3 (*)	Thin Film, 93.1 k, 0.1 W, 0.1%, AEC-Q200	0603	Panasonic	ERA-3AEB9312V
R4	Thick Film, 10 k, 0.1 W, 0.1%, AEC-Q200	0603	Panasonic	ERA-3ARB103V
R5 (DNP)	N/A	0603	N/A	N/A
R6	Thick Film, 100, 0.5 W, 5%, AEC-Q200	0805	Vishay	CRCW0805100R1NEAHP
R7	Thick Film, 10 k, 0.1 W, 1% AEC-Q200	0603	Yageo	AC0603FR-0710KL
R8	Thick Film, 3.3, 0.1 W, 1% AEC-Q200	0603	Yageo	AC0603FR-073R3L
R9 (*) (opt)	Thick Film, 10 k, 0.25 W, 1%, AEC-Q200	0603	Panasonic	ERJ-UP3F1002V
R10 (*) (opt)	Thick Film, 2.2 k, 0.1 W, 1%, AEC-Q200	0603	Panasonic	ERJ-3EKF2201V
Q1	MOSFET N-Channel, 40 V, AEC-Q101	SOT23-3	Vishay	SQ2318AES-T1_GE3
U1	PSR Flyback Controller 65 V 4.5 A AEC-Q200	SO-8	Analog Devices	LT8302HS8E#WPBF
T1 (*)	Transformer 7 uH, 4.5 A, 7.5 pF AEC-Q200	EP-7	Würth Elektronik	<b>750318131</b>

Table 7: Bill-of-Materials (BoM) for  $V_{out} = +15\text{ V} / -4\text{ V}$ . Option 2: AEC-Q qualified components

(\*) For  $V_{out} = +19\text{ V} / -4\text{ V}$  variant, use:

## REFERENCE DESIGN

### RD001 | 6 W Bipolar isolated auxiliary supply for SiC-MOSFET & IGBT gate driver

D5	Zener 19.23-20.22 V, 0.5 W, AEC-Q101	μSMF	Vishay	PLZ20C-HG3/H
D6	Zener 4.30-4.57 V, 0.5 W, AEC-Q101	μSMF	Vishay	PLZ4V3C-HG3/H
R3	Thin Film, 95.3 k, 0.1 W, 0.1%, AEC-Q200	0603	Panasonic	ERA-3AEB9532V
R9 (opt)	Thick Film, 13 k, 0.1 W, 1%, AEC-Q200	0603	Panasonic	ERJ-U03F1302V
R10 (opt)	Thick Film, 2.2 k, 0.1 W, 1%, AEC-Q200	0603	Panasonic	ERJ-U03F2201V
T1	Transformer 7 μH, 4.5 A, 7.5 pF AEC-Q200	EP-7	Würth Elektronik	<b>750319497</b>

Table 8: Component variation for  $V_{out} = +19\text{ V} / -4\text{ V}$  variant. Option 2: AEC-Q qualified components

(\*) For  $V_{out} = +20\text{ V} / -5\text{ V}$  variant, use:

D5	Zener 20.15-21.20 V, 0.5 W, AEC-Q101	μSMF	Vishay	PLZ22A-HG3/H
D6	Zener 5.45-5.63 V, 0.5 W, AEC-Q101	μSMF	Vishay	PLZ5V6B-HG3/H
R3	Thin Film, 94.2 k, 0.1 W, 0.1%, AEC-Q200	0603	KOA Speer	RN73R1JTTD9422B25
R9 (opt)	Thick Film, 18 k, 0.1 W, 1%, AEC-Q200	0603	Panasonic	ERJ-U03F1802V
R10 (opt)	Thick Film, 3.3 k, 0.1 W, 1%, AEC-Q200	0603	Panasonic	ERJ-3EKF3301V
T1	Transformer 7 μH, 4.5 A, 7.5 pF AEC-Q200	EP-7	Würth Elektronik	<b>750319496</b>

Table 9: Component variation for  $V_{out} = +20\text{ V} / -5\text{ V}$  variant. Option 2: AEC-Q qualified components

## 13.WE-AGDT SERIES

The **WE-AGDT** (Auxiliary Gate Drive Transformer) transformers from Würth Elektronik are each optimized for its corresponding reference design. They provide bipolar (+ 15 V / - 4 V, + 19 V / - 4 V, + 20 V / - 5 V) as well as unipolar (15 to 20 V) options, with input voltage ranging from 9 to 36 V and maximum output power of 3 to 6 W. They are optimized for SiC-based applications, but they are also suitable for driving IGBT and power MOSFETs alike, and even high-voltage GaN-FETs with an additional output regulation stage.

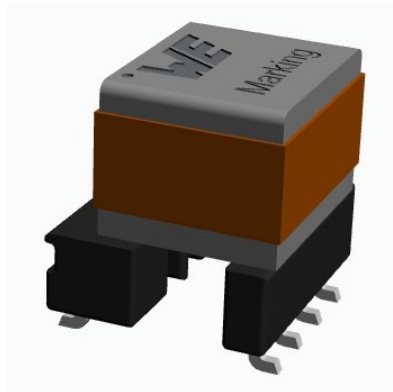

Figure 36: **WE-AGDT** (Auxiliary Gate Drive Transformer)

### Characteristics

- Interwinding capacitance as low as 6.8 pF typical
- Flyback with primary side regulation
- High efficiency and very compact. Surface mount EP7
- Common control voltages for SiC MOSFET & IGBT
- Wide range input voltages 9 to 36 V
- Safety: IEC62368-1 / IEC61558-2-16
- Basic insulation
- Dielectric insulation up to 4 kV

## REFERENCE DESIGN

RD001 | 6 W Bipolar isolated auxiliary supply for SiC-MOSFET & IGBT gate driver

- Temperature class B
- Reference designs with TI and ADI controllers

### Applications

Industrial drives, AC motor inverters, electric vehicle powertrain, battery chargers, solar inverters, data centers, uninterruptible power supplies, active power factor correction, switching power supplies with SiC-MOSFETs.

Order code	V <sub>in</sub> range (V)	V <sub>out1</sub> (V)	V <sub>out2</sub> (V)	C <sub>w_w</sub> (pF)	Frequency max (kHz)	IC Reference Design	Power (W)	
<a href="#">750317893</a>	9 – 18	15 – 20	-	6.8	350	LM5180	3	
<a href="#">750317894</a>	9 – 18	+15	-4	7.5			5	
<a href="#">750318207</a>	18 – 36	15 – 20	-	8.2			LT8302	6
<a href="#">750318208</a>	18 – 36	+15	-4	7.0				
<a href="#">750318114</a>	9 – 18	15 – 20	-	6.8				
<a href="#">750318131</a>	9 – 18	+15	-4	7				
<a href="#">750319497</a>	9 – 18	+19	-4	7				
<a href="#">750319496</a>	9 – 18	+20	-5	7				

Table 10: *WE-AGDT* transformer series

# REFERENCE DESIGN

## RD001 | 6 W Bipolar isolated auxiliary supply for SiC-MOSFET & IGBT gate driver

### IMPORTANT NOTICE

The Application Note is based on our knowledge and experience of typical requirements concerning these areas. It serves as general guidance and should not be construed as a commitment for the suitability for customer applications by Würth Elektronik eiSos GmbH & Co. KG. The information in the Application Note is subject to change without notice. This document and parts thereof must not be reproduced or copied without written permission, and contents thereof must not be imparted to a third party nor be used for any unauthorized purpose.

Würth Elektronik eiSos GmbH & Co. KG and its subsidiaries and affiliates (WE) are not liable for application assistance of any kind. Customers may use WE's assistance and product recommendations for their applications and design. The responsibility for the applicability and use of WE Products in a particular customer design is always solely within the authority of the customer. Due to this fact it is up to the customer to evaluate and investigate, where appropriate, and decide whether the device with the specific product characteristics described in the product specification is valid and suitable for the respective customer application or not.

The technical specifications are stated in the current data sheet of the products. Therefore the customers shall use the data sheets and are cautioned to verify that data sheets are current. The current data sheets can be downloaded at [www.we-online.com](http://www.we-online.com). Customers shall strictly observe any product-specific notes, cautions and warnings. WE reserves the right to make corrections, modifications, enhancements, improvements, and other changes to its products and services. WE DOES NOT WARRANT OR REPRESENT THAT ANY LICENSE, EITHER EXPRESS OR IMPLIED, IS GRANTED UNDER ANY PATENT

RIGHT, COPYRIGHT, MASK WORK RIGHT, OR OTHER INTELLECTUAL PROPERTY RIGHT RELATING TO ANY COMBINATION, MACHINE, OR PROCESS IN WHICH WE PRODUCTS OR SERVICES ARE USED. INFORMATION PUBLISHED BY WE REGARDING THIRD-PARTY PRODUCTS OR SERVICES DOES NOT CONSTITUTE A LICENSE FROM WE TO USE SUCH PRODUCTS OR SERVICES OR A WARRANTY OR ENDORSEMENT THEREOF.

WE products are not authorized for use in safety-critical applications, or where a failure of the product is reasonably expected to cause severe personal injury or death. Moreover, WE products are neither designed nor intended for use in areas such as military, aerospace, aviation, nuclear control, submarine, transportation (automotive control, train control, ship control), transportation signal, disaster prevention, medical, public information network etc. Customers shall inform WE about the intent of such usage before design-in stage. In certain customer applications requiring a very high level of safety and in which the malfunction or failure of an electronic component could endanger human life or health, customers must ensure that they have all necessary expertise in the safety and regulatory ramifications of their applications. Customers acknowledge and agree that they are solely responsible for all legal, regulatory and safety-related requirements concerning their products and any use of WE products in such safety-critical applications, notwithstanding any applications-related information or support that may be provided by WE.

CUSTOMERS SHALL INDEMNIFY WE AGAINST ANY DAMAGES ARISING OUT OF THE USE OF WE PRODUCTS IN SUCH SAFETY-CRITICAL APPLICATIONS.

### USEFUL LINKS



Application Notes  
[www.we-online.com/appnotes](http://www.we-online.com/appnotes)



**REDEXPERT** Design Platform  
[www.we-online.com/redexpert](http://www.we-online.com/redexpert)



Toolbox  
[www.we-online.com/toolbox](http://www.we-online.com/toolbox)



Product Catalog  
[www.we-online.com/products](http://www.we-online.com/products)

### CONTACT INFORMATION



[appnotes@we-online.com](mailto:appnotes@we-online.com)  
Tel. +49 7942 945 - 0



Würth Elektronik eiSos GmbH & Co. KG  
Max-Eyth-Str. 1 · 74638 Waldenburg  
Germany  
[www.we-online.com](http://www.we-online.com)