

# Application Note

## Supercapacitor – A Guide for the Design-In Process



ANP077 // RENÉ KALBITZ, FRANK PUHANE

### 1 Abstract

Supercapacitors (SCs) are easy to use energy storage devices and are in many aspects comparable to batteries. They can be charged by any current limited power source and drive any electrical applications. [1,2,3] SCs require, like any other energy storage system, a certain infrastructure in order to store and deliver their energy. In the course of this application note, it shall be discussed how the capacitor can be utilized as a simple energy storage device and show how charging as well as operating times can be calculated. We exemplify the utilization in a circuit design that allows the charging of the capacitor under non-ideal conditions and the operation of any electronic application.

### 2 Introduction

The term Supercapacitor (SC) is widely used. It is however, an ambiguous term, for it denotes an entire family of capacitive energy storage technologies. [1] The correct technical term for the SCs in our current portfolio is electric double layer capacitor (EDLC). In this application note, we may use both terms synonymously.

When it comes to charging and discharging, the SCs have two properties that need consideration. First, unlike batteries, the SCs voltage depends on its charging state. Thus, the voltage at the terminals increases or decreases as soon as the SC becomes charged or discharged. Considering the discharging process this property is certainly unfavourable, since electronic applications require a constant working voltage.

Second, SCs can be charged with relatively high currents, which might lead to a semi-short-circuit condition for the power supply. Later, we discuss the correct usage of the SC under two different modes of operation: constant current as well as constant voltage charging.

Although the design-in process for SC can be different from case to case, it is at least necessary to consider the following issues:

- Calculation of the required energy capacity based on the expected power demand.
- Determination of the required capacitance  $C$  in accordance to the specification of the load including DC-DC conversion efficiency and lowest operation voltage and charging voltage.
- Identify the charging regime and calculate the corresponding charging time. In case of constant voltage charging, choose the protective resistor in accordance to the specification of the power unit.

It is not possible to give a simple guideline that may be applied to any situation; however, we will cover the most important aspects. Therefore we first provide some theoretical background before the actual example of application is discussed in more detail.

### 3 Theoretical Background

#### 3.1 Energy Capacity

One important quantity that needs consideration at the beginning of the design process is the amount of the required energy. In other words, we need to calculate the amount of energy  $E = P \cdot t$ , where  $P$  is the gross power demand and  $t$  the desired time of operation.<sup>1</sup>

In the next step, the energy needs to be related to the energy capacity of the SC, i.e. to its capacitance.

The amount of usable electrical energy  $E$  stored in an SC with capacitance  $C$  is given by

$$E = \frac{1}{2} \cdot C \cdot (V_1^2 - V_2^2) \quad (\text{Eq.1})$$

where  $V_1$  denotes charging voltage and  $V_2$  the cut-off voltage. Please note that  $V_1$  is not necessarily the rated voltage  $V_r$ , but the actual cell voltage of the SC. Even without concrete numbers, the above equation conveys an important insight. A SC that is only charged up to  $\frac{1}{2}$  of its rated voltage holds only a quarter of its full energy capacity. Hence, to make full use of the storage capacities, it is important to ensure that the capacitor is fully charged. In an idealized case, the SC is charged at  $V_1 = V_r$  and during the operation entirely drained down to  $V_2 = 0$  V.

Due to this voltage dependence, it is important to know the parameters of the DC-DC converter in the surrounding circuit. Once these parameters are known, the SC capacitance may be calculated with

$$C = \frac{2 \cdot E}{(V_1^2 - V_2^2)}. \quad (\text{Eq.2})$$

At this point, the SC needs to be selected from the catalogue in accordance to all the other demands like actual size, rated temperature and so on. Once the capacitance and the internal resistance of the SC is known, it is possible to calculate the charging and discharging characteristics.

#### 3.2 Concerning Charging Regime

In theory, the SC may be charged either with a constant voltage source or with a constant current source. No matter what kind of power source is used, in practice all power units will have a maximum current output. We may therefore distinguish two situations:

<sup>1</sup> If the power  $P(t)$  is a function of time then the energy is calculated with  $E = \int P(t) dt$ .

# Application Note

## Supercapacitor – A Guide for the Design-In Process



- The power supply can be safely operated at its maximum output current, where the supply ensures safe operation itself.
- The power supply may not be driven at its maximum rated current without risk of damaging the power supply itself or the capacitor, thus requiring a form of current restriction.

In the first case, the power supply operates under constant current conditions with its upper voltage limit set to  $V_r$ . In the latter case, the power supply needs to be operated as a constant voltage source.

The design-in for the SC in the first case is relatively simple, since it is only necessary to set the constant current and the output voltage of the power unit to meet the requirements of the SC. How that setting is actually executed depends on the used power supply unit and shall therefore not be discussed in this application note. We will look at the charging under constant current conditions at a later point in time.

The design for the latter situation that uses constant voltage shall be discussed in the following section.

### 3.3. Constant Voltage Charging (CVC)

In cases where the power supply cannot handle capacitive loads, it is necessary to restrict the current by a protective resistor.

It is recommended by the IEC 62391 standard to use a protective resistor with  $R_p = 1 \text{ k}\Omega$  in series with the SC as shown in Figure 1. Deviation from this standard to facilitate an efficient charging time is necessary, if the limitations from the power supply are considered. In this application note, we may also refer to  $R_p$  as the parasitic resistance to model all "undesired" resistances due to contacts and cables, which are connected in series with the SC.

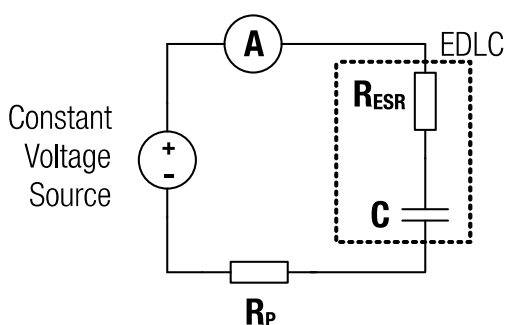

Figure 1: Typical circuit used for the charging of capacitors with a constant voltage source.

The protective resistor is to be omitted if a source of constant current is used.  $R_p$  may also be used to model serial parasitic resistances.

Before we discuss the calculation of the protective resistance, we will briefly review the basics of the voltage-time dependency (charging characteristic) of the SC under constant resistance conditions.

If a discharged SC is charged by an ideal voltage source at its rated voltage  $V_r$ , then the time dependent increase in cell voltage  $V(t)$  is described by

$$V(t) = V_r \cdot \left( 1 - e^{-\frac{t}{(R_{ESR} + R_p) \cdot C}} \right). \quad (\text{Eq.3})$$

The corresponding plot of the charging characteristic, given in Figure 2, illustrates the time-dependent bounded exponential increase of cell voltage for R-C circuits. The upper boundary is the charging voltage, which in our consideration is equal to the rated voltage  $V_r$ . The corresponding charge current, which is also given in Figure 2, is calculated with

$$I(t) = \frac{V_r}{(R_{ESR} + R_p)} \cdot e^{-\frac{t}{(R_{ESR} + R_p) \cdot C}}. \quad (\text{Eq.4})$$

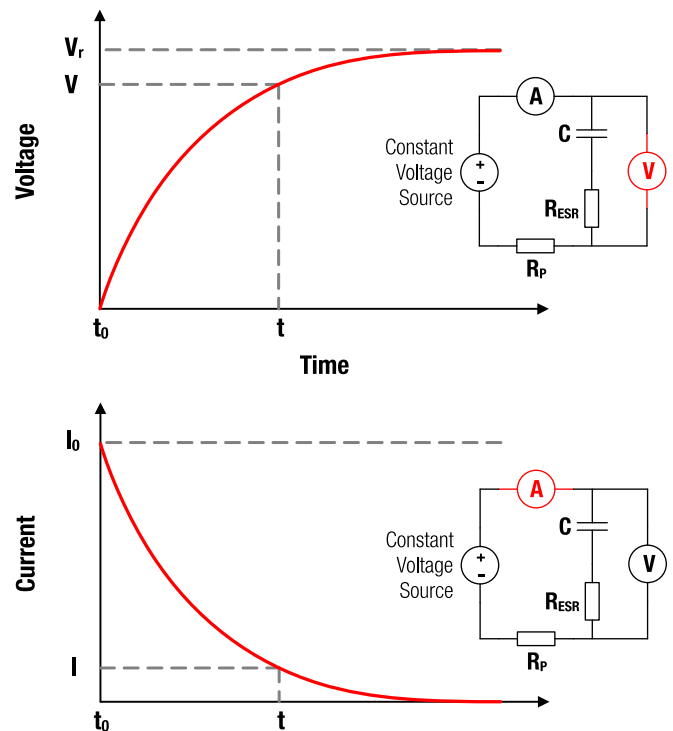

Figure 2: Plot of charging characteristic for a capacitor with constant voltage source.

The characteristic R-C time constant of this system is given by

$$\tau = (R_{ESR} + R_p) \cdot C. \quad (\text{Eq.5})$$

If the capacitor has a remaining voltage  $V_0$ , then the effective charging time  $t_c$  can be calculated with

$$t_c = \tau \cdot \ln\left(\frac{V_r}{V_r - V_0}\right) = (R_{ESR} + R_p) \cdot C \cdot \ln\left(\frac{V_r}{V_r - V_0}\right). \quad (\text{Eq.6})$$

# Application Note

## Supercapacitor – A Guide for the Design-In Process



For an initially empty capacitor, the charging time to reach over 99 % of the charging voltage can be well estimated with  $t_c = 2 \cdot \pi \cdot \tau = 2 \cdot \pi \cdot (R_{ESR} + R_p) \cdot C$ . One may of course change this approximation to their liking, however using  $2 \cdot \pi \approx -\ln(1 - 0.998\dots)$  has the advantage that the charging time  $t_c$  corresponds to the cut-off frequency of R-C units, generally defined as

$$f = \frac{1}{2 \cdot \pi \cdot R \cdot C} = \frac{1}{t_c} \quad (\text{Eq.7})$$

Since the ESR is usually in the order of  $m\Omega$ , the R-C time is easily dominated by  $R_p$ , which, depending on the case, can be considered as a parasitic or protective resistor. Thus, the charging current and subsequently the charging time can be adjusted/influenced by the protective resistor.

For the circuit containing  $R_p$  (Figure 2), the charging current is defined as

$$I = \frac{V_r - V}{R_{ESR} + R_p} \quad (\text{Eq.8})$$

The term  $V_r - V$  is the voltage difference between charging voltage of the source, in this case the  $V_r$ , and the voltage at the terminals of the SC  $V = V(t)$ . By rearranging the equation (Eq.8) for  $R_p$  we arrive at

$$R_p = \frac{V_r - V}{I} - R_{ESR} \quad (\text{Eq.9})$$

With this equation, we are able to determine the minimal required protective resistor.

The current  $I$  in the above formulas can be interpreted as the maximum allowable current. It is either determined by the upper current limit of the power unit or the maximum rated current of the SC (given in the data sheet). All of the other values such as  $C$ ,  $V_r$  as well as  $R_{ESR}$  are given in the SCs data sheet.

It should be noted at this point that the SC may only in theory be operated under short circuit conditions. Operating the SC above the designated current limits may not cause an immediate fatal breakdown, but leads to a drastically decreased component expected lifetime.

Equation (Eq.8) also illustrates that the maximum current at which an SC can be charged, depends on the  $V_r - V$ . In other words an increase in cell voltage is always accompanied by a decrease in maximum charging current, whereas the magnitude or "strength" of this decrease is given by  $1/(R_{ESR} + R_p)$ .

### 3.4. Constant current charging (CCC)

As already mentioned above, another way of charging utilizes a constant current source  $I_c$ . We may introduce the subscript  $c$ , to clarify that the current is actively kept constant by the power supply. The practical advantage of using a power supply with an active current regulation is that an additional protective resistor is not needed.

In case of charging the SC at  $I_c$ , the voltage at the terminals is

$$V(t) = \frac{I_c}{C} \cdot (t - t_0) + V_0 \quad (\text{Eq.10})$$

where  $V_0$  denotes the residual voltage of the capacitor. The corresponding schematic plot in Figure 3 illustrates the linear voltage dependence on the charging time.

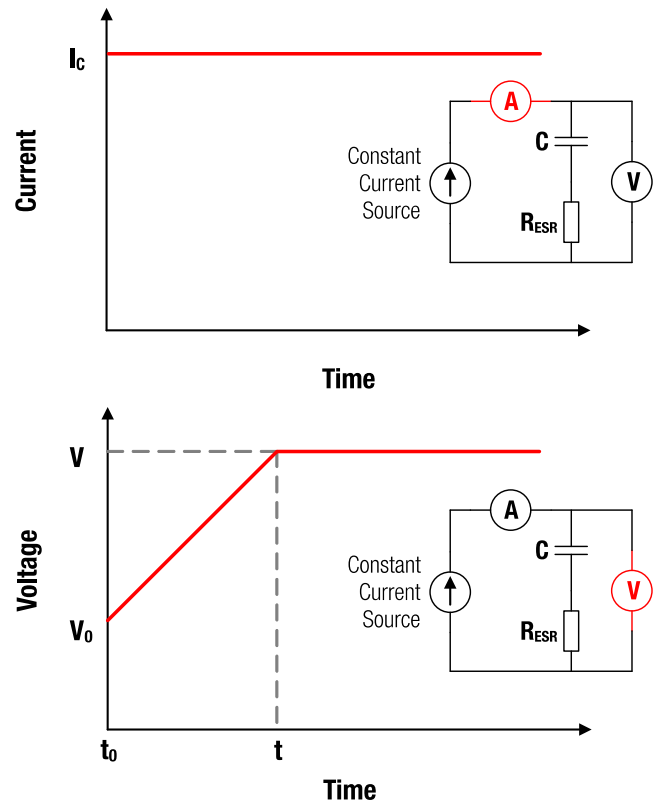

**Figure 3: Plot of charging characteristic using a constant current source.**

$V = V(t)$  is the voltage at the terminals of the SC, as it is charged with a constant current. We may omit the subscript for the sake of simplicity. Assuming the capacitor is fully charged ( $V(t) = V_r$ ), the charging time in the constant current regime is calculated with

$$t_c = \frac{C}{I_c} \cdot (V_r - V_0) \quad (\text{Eq.11})$$

The charging time under constant current charging is directly proportional to  $C$  and inversely proportional to  $I_c$ . Hence, a doubling of the charging current halves the charging time and a doubling of  $C$  doubles the charging time.

As already mentioned during the discussion of equation (Eq.8), it is physically not possible to charge a capacitor up to 100 % by a constant current  $I_c$ , as long as the applied voltage is not allowed to be larger than  $V_r$ . At a certain point  $I_c \cdot (R_{ESR} + R_p)$  will be larger than  $V_r - V(t)$ . Thus, depending on the charging current and the total series resistance, the

# Application Note

## Supercapacitor – A Guide for the Design-In Process



effective charging time may be significantly longer than calculated with equation (Eq.11). In this case, the charging time has to be calculated with equation (Eq.6). It is therefore important to keep the ohmic losses as low as possible.

### 3.5. The Discharging Process

For the discharging process, we may generally distinguish between three scenarios:

- constant power discharge,
- constant resistance discharge and
- constant current discharge.

In the example application we use a step-up converter, which is draining the SC at a constant power  $P_c$ . We may therefore set the focus of the discussion on this case. For the sake of simplicity, we will assume that the power consumption of the application  $P_c$  is constant and that the step-up converter is working with 100 % efficiency.

The SC with the capacitance  $C$  will hold a certain voltage  $V_0$ . After discharge at constant power output  $P_c$  the voltage has dropped to

$$V(t) = \sqrt{V_0^2 - \frac{2 \cdot P_c}{C} (t - t_0)} \quad (\text{Eq.12})$$

$V = V(t)$  is the voltage at the terminals of the SC, as it is discharged with a constant power. We may again omit the subscript for the sake of simplicity. Using the relationship  $P_c = V \cdot I$  we obtain the expression for the corresponding current

$$I(t) = \frac{P_c}{\sqrt{V_0^2 - \frac{2 \cdot P_c}{C} (t - t_0)}} \quad (\text{Eq.13})$$

The corresponding voltage and current characteristics are given in figure 4.

The time it takes to discharge the SC from  $V_0$  to  $V$  is calculated with

$$t_{\text{dis}} = (t - t_0) = \frac{C}{2 \cdot P_c} \cdot (V_0^2 - V^2) \quad (\text{Eq.14})$$

The discharging time as well as the calculated charging times above linearly depend on the capacitance, i.e. doubling the capacitance, doubles the dis/charging time. However, the dependency of the discharging time on discharge power is inversely proportional, i.e. doubling of the discharge power, halves the discharge time. The utilized step-up converter in our example is discharging the SC from  $V_r = 2.7 \text{ V}$  to its cut-off voltage  $V = 1 \text{ V}$  at a constant power of  $P_c \approx 0.75 \text{ W}$ . The time required for this process according to the above equation is

$$\frac{100 \text{ F}}{2 \cdot 0.75 \text{ W}} ((2.7 \text{ V})^2 - (1 \text{ V})^2) \approx 420 \text{ s} \quad (\text{Eq.15})$$

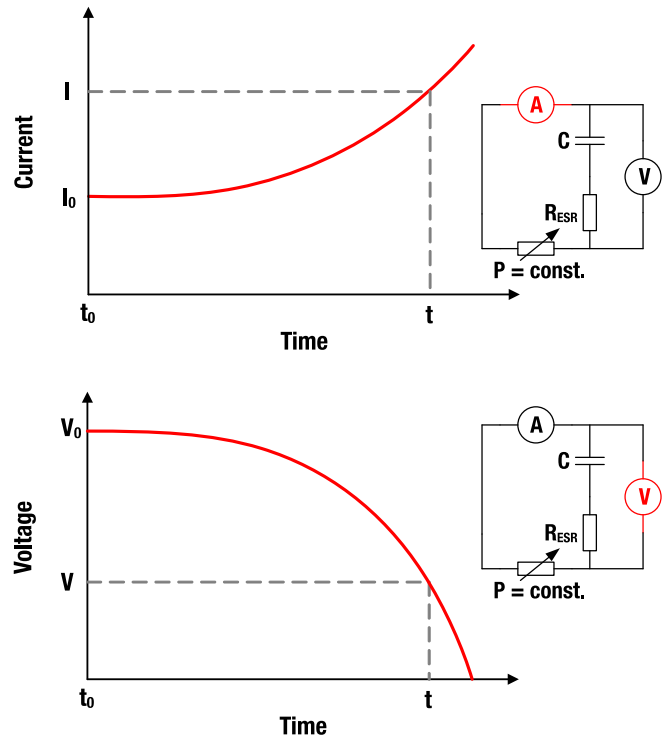

Figure 4: Plot current (top) and voltage (bottom) characteristic of SC unit for constant power discharge.

## 4 Example of Application

### 4.1. The Circuit

In our application example we show a case where the actual power source as well as the application work at higher voltages than the SCs rated voltage. We therefore use a step-down converter for charging and a step-up converter for powering the actual test application, which is a wireless power transmitter with a simple LED panel as a load. We wanted to demonstrate that under these real conditions SCs may be utilized to work as a backup power supply, capable of driving the application for about 5 minutes.

As a power source we used the HMP4040 programmable power supply from Rohde & Schwarz, which provides a voltage of 12 V (DC) to the step-down Converter, i.e. constant current source. The step-down converter (evaluation board: 178004) facilitates the constant current charging of the SC even under conditions where the actual power source is operating at voltages  $>V_r$ . The step-up converter (synchronous boost converter LTC3402 from Analog Devices) provides the power required by the test application, which in this case is an LED panel. The power between the step-up converter and LED panel is transferred by a wireless power unit. Please see Figure 5 for more details.

# Application Note

## Supercapacitor – A Guide for the Design-In Process

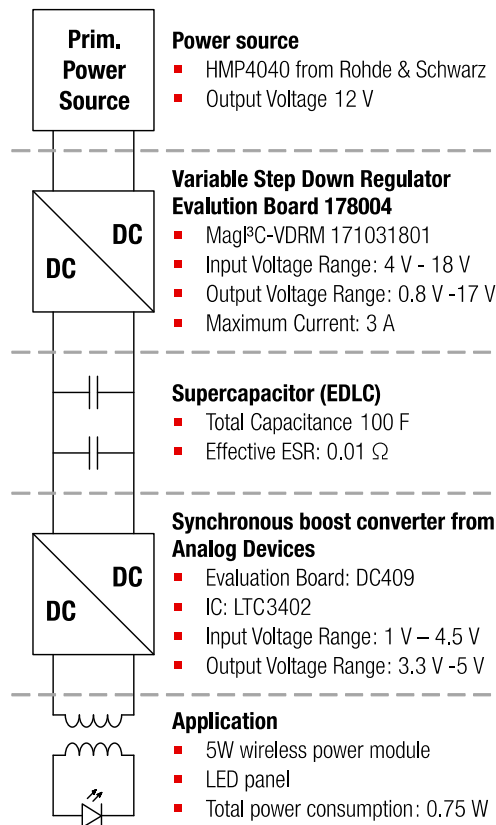

Figure 5: Application example.

The current and voltage characteristics were measured with the HMC 8012 digital multimeter from Rohde & Schwarz and operated by means of a customized LabView program.

For the measurements presented below of the voltage and current characteristics during the charging and discharging processes, the step-down converter or the step-up converter were disconnected from the SC unit, respectively.

### 4.2. Charging Process

Since we intend to drive an application with a power consumption of around  $P = 0.8 \text{ W}$  (including conversion losses) for about  $t = 5 \text{ min}$ , we need a total amount of energy of about  $E = P \cdot t = 0.8 \text{ W} \cdot 300 \text{ s} = 240 \text{ J} = 0.067 \text{ Wh}$ . Since the utilized converter is charging at 2.7 V we need at least a capacitance of

$$C = 2 \cdot \frac{E}{V_1^2 - V_2^2} = 2 \cdot \frac{240 \text{ J}}{(2.7 \text{ V})^2 - (1 \text{ V})^2} \approx 76 \text{ F} \quad (\text{Eq.16})$$

(rearrange (Eq.1) for C).

In our example, we charge two capacitors in parallel which each have a capacitance of 50 F. Thus, the total capacitance of the entire SC unit is 100 F with a rated voltage of 2.7 V. Since the minimal required capacitance is 76 F, the unit will provide enough energy capacity. Since both SC are in parallel, the effective ESR of this unit is calculated by

$$\frac{1}{R_{\text{ESR}}} + \frac{1}{R_{\text{ESR}}} = \frac{2}{R_{\text{ESR}}} \quad (\text{Eq.17})$$

With the data sheet value, we obtain an effective serial resistance of  $R_{\text{ESR}}/2 = 0.01 \Omega$ . In order to minimize the number of variables, we will refer to this value as the equivalent series resistance  $R_{\text{ESR}}$ .

For charging we use a step-down converter (current source), converting a DC input voltage of 12 V to a DC output voltage of 2.7 V. The advantage of using this power supply is that it can handle a maximum current of 3 A continuously. It is therefore not necessary to use a protective resistor for this layout. Before the measurement, the SC-unit was completely charged and subsequently discharged as recommended by the IEC 62391 standard. Since our step-up converter has an input cut-off voltage of 1 V, we have chosen the residual voltage for the example to be around 1 V. By doing so, we intend to provide a more realistic working example. During the charging process the load has been disconnected.

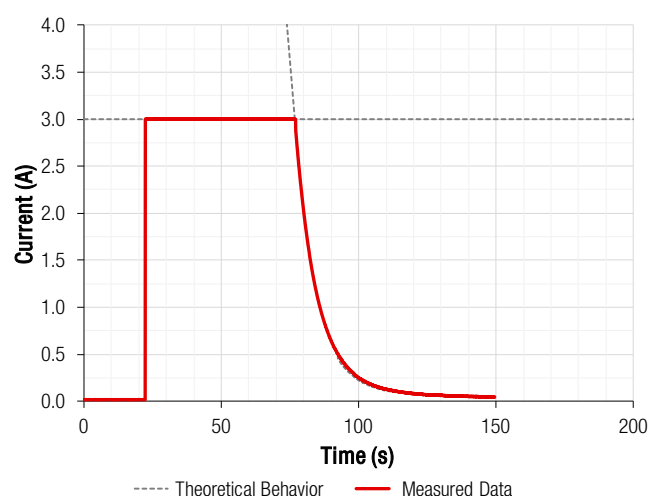
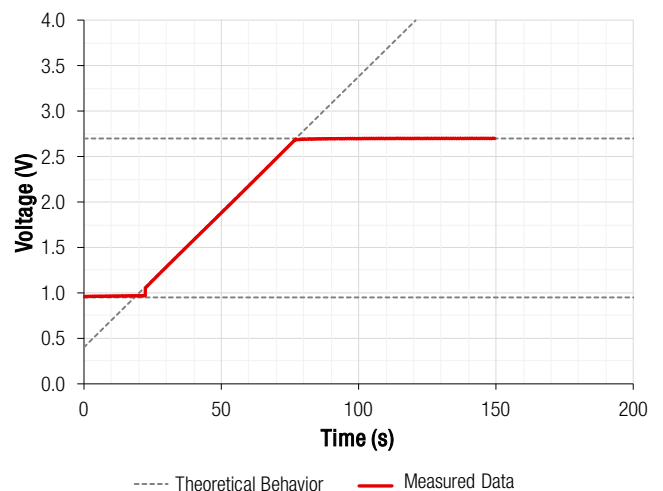

Figure 6: Voltage (top) and current (bottom) characteristic of SC unit for constant current charging. The constant current charging period is subsequently followed by constant voltage charging.

# Application Note

## Supercapacitor – A Guide for the Design-In Process



Figure 6 shows the measured as well as the calculated charging characteristics of the SC unit as it is charging with a constant current from 0.95 V to 2.7 V. For the calculation of the theoretical graphs, the following parameters were used  $R_{ESR} + R_p = 0.08 \Omega$ ,  $C = 100 \text{ F}$  and  $V_r = 2.7 \text{ V}$ . The voltage increases linearly from the residual voltage 0.95 V to almost 2.7 V. During this period of time, lasting from around 32 sec to 86 sec, the current is regulated constantly at 3 A. The charging time for this process is calculated as

$$\frac{100 \text{ F}}{3 \text{ A}} (2.7 \text{ V} - 0.95 \text{ V}) \approx 53 \text{ s} \quad (\text{Eq.18})$$

This CCC process is then followed by a CVC process, as can be seen by the exponential decrease of the charging current. The phenomenon was already mentioned in the introduction and occurs when the difference between charging voltage and applied voltage becomes smaller than  $\Delta V = I_c \cdot (R_{ESR} + R_p)$ . Thus, the charging time contributed by the second process is  $\approx 30 \text{ s}$  and can be calculated with  $(R_{ESR} + R_p) \cdot C \cdot \ln((V_r \cdot 0.002)/\Delta V)$ .  $R_p$  is an estimate, for it cannot easily be measured directly. We have determined it by a mathematical fit of the above equations and found that the parasitic resistance is about  $R_p \approx 0.07 \Omega$ . However, the most practical approach in many cases is a test measurement during the design-in phase.

We also want to mention that, due to ohmic parasitic resistance of the wires and contacts, the measured voltage is not exactly the voltage of the SC unit. It is for this reason that during the second CCC process the voltage graph shows an almost constant value of 2.7 V but does not show a distinct exponential increase.

Apart from this parasitic resistance of  $R_p \approx 0.07 \Omega$ , all other values used for the calculation compare to the technical parameters of the SCs. Since the setup was developed for demonstration purposes only, the focus was set on a strictly modular and easily accessible design.

As already mentioned above, the current and voltage curves presented in Figure 6 have been measured with the load disconnected from the SC unit. Therefore, the current reading drops to zero as the capacitor approaches its fully charged state. Under realistic working conditions, however, the load would cause a constant current offset due to the constant power consumption of 0.75 W, as is shown in Figure 7. Here the current converges towards

$$0.28 \text{ A} = \frac{P_c}{V} = \frac{0.75 \text{ W}}{2.7 \text{ V}} \quad (\text{Eq.19})$$

(instead of 0 A as in Figure 7) as the SC becomes charged. Charging time as well as voltage characteristics remain the same as discussed above.

In this section, we have shown how the charging process of the given example can be described as a two-step process and how the charging time can be calculated in such a case.

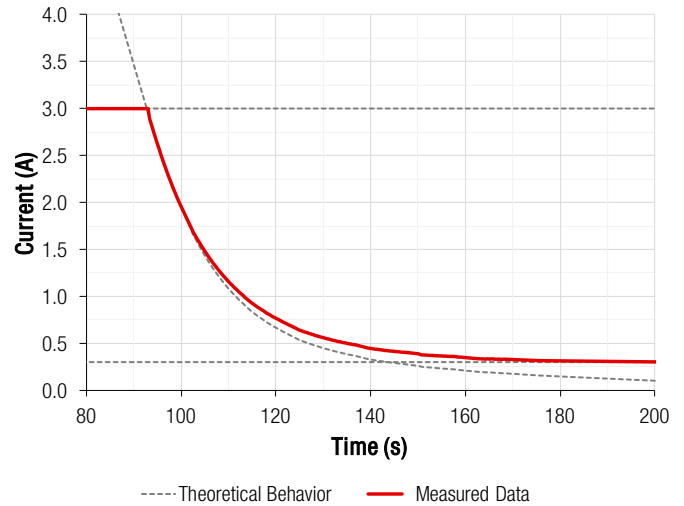

**Figure 7: Charging Current with off-set current of 0.3 A.**

In the next section, this application note focuses on the discussion of the discharge process. Therefore, we will also compare the measured data with the theoretical model and show how discharging times are calculated.

### 4.3. Discharging Process

The utilized step-up converter in our example is discharging the SC from  $V_0 = 2.7 \text{ V}$  to its cut-off voltage  $V = 1 \text{ V}$ . It drives a wireless power transmitter with a small array of LEDs at a voltage of 5 V with a power consumption of around 0.75 W. It is important to consider the conversion losses, which lead to an overall increase of the power consumption. These conversion efficiencies are usually not constant but change with the input voltage, ambient temperature as well as other design factors.

In our example the efficiency changes from 90 % at 2.7 V down to around 70 % as the converter approaches its cut-off voltage of 1 V. In order to obtain an accurate physical model, the constant value  $P_c$  would have to be replaced by an appropriate function  $P_c(V)$ . We shall refrain from discussing this efficiency dependence in more detail, since it is just a technicality and does not contribute to a deeper understanding of the discharging process.

For the sake of simplicity, we will use the average power output of  $\bar{P}_c = 0.75 \text{ W}$ , calculated with

$$\bar{P}_c = \frac{1}{\Delta t} \int P(t) dt. \quad (\text{Eq.20})$$

The function  $P(t)$  was determined experimentally on the basis of the overall current and voltage curves of the converter and LED array.

Since we have performed the calculation based on an average power output, the current curve in Figure 8 deviates increasingly from the theoretical curve as the SC is discharged. The time required for this discharging process according to the above equation is

# Application Note

## Supercapacitor – A Guide for the Design-In Process



$$\frac{100 \text{ F}}{2 \cdot 0,75 \text{ W}} ((2,7 \text{ V})^2 - (1 \text{ V})^2) \approx 420 \text{ s.} \quad (\text{Eq.21})$$

which is in good agreement with the measured voltage.

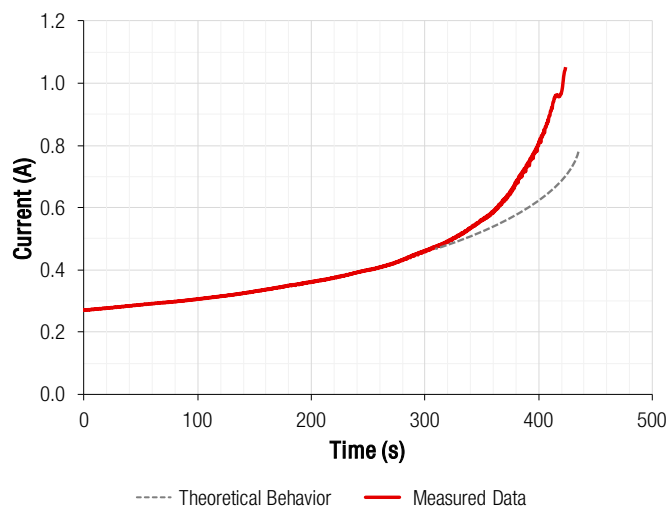
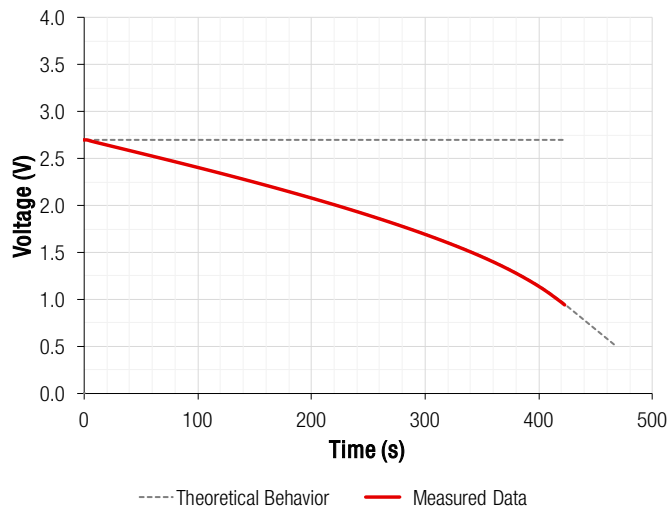

**Figure 8: Voltage (top) and current (bottom) characteristic of SC unit for constant power discharge. Dashed line shows the theoretical discharge behaviour. Red line shows the actual measured data.**

### 5 Summary

The course of action, described in this application note, is a blue print for the definition of SC charge/discharge circuits. We have demonstrated how SCs act as an intermediate power unit depending on the specification of the application. SCs can be suitable to keep the voltage stable when the power supply fluctuates. Further, we have calculated the required energy capacity for the application and have chosen suitable SCs accordingly.

We have identified two charging processes. Initially the capacitor charges with a constant current until a certain charged state threshold, which subsequently leads to charging at a constant voltage.

We also demonstrated that the discharge with a step-up converter can be described as a constant power discharge process.

# Application Note

## Supercapacitor – A Guide for the Design-In Process



### A. Appendix

#### A.1. Complete Application

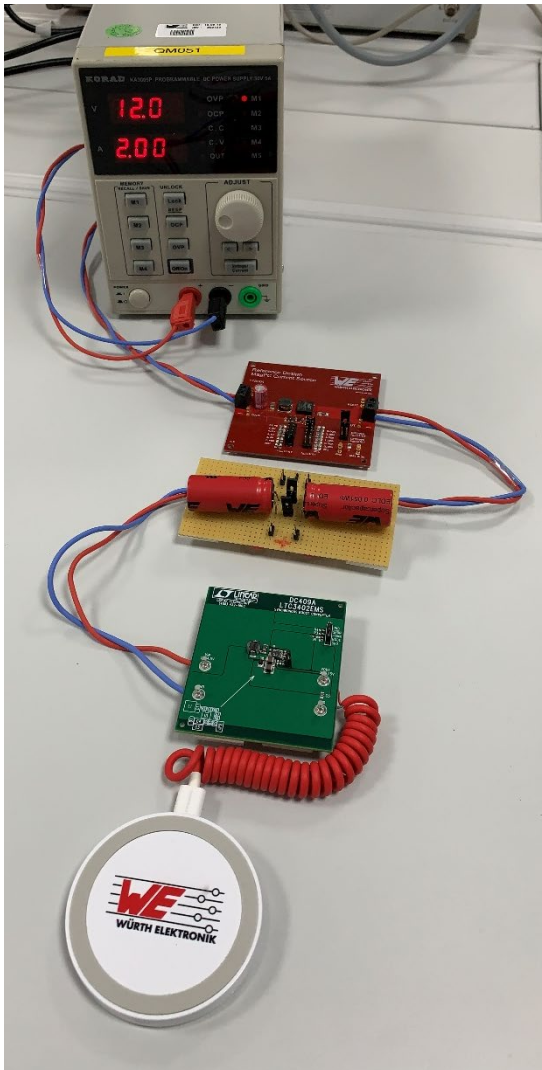

Figure 9: Picture of the complete application with the different power converter, Supercapacitor bank and the load but with a different power supply.

#### A.2. References

- [1] F. Beguin and E. Frackowiak (eds.), **Supercapacitors Materials, Systems, and Applications**, WILEY-VCH Verlag (2013)
- [2] B. E. Conway, **Electrochemical Supercapacitors, Scientific Fundamentals and Technological Applications**, Kluwer Academic / Plenum Publishers, New York (1999)
- [3] N. Kularatna, **Energy Storage Devices for Electronic Systems (Rechargeable Batteries and Supercapacitors)**, Elsevier (2015)

# Application Note

## Supercapacitor – A Guide for the Design-In Process



### IMPORTANT NOTICE

The Application Note is based on our knowledge and experience of typical requirements concerning these areas. It serves as general guidance and should not be construed as a commitment for the suitability for customer applications by Würth Elektronik eiSos GmbH & Co. KG. The information in the Application Note is subject to change without notice. This document and parts thereof must not be reproduced or copied without written permission, and contents thereof must not be imparted to a third party nor be used for any unauthorized purpose.

Würth Elektronik eiSos GmbH & Co. KG and its subsidiaries and affiliates (WE) are not liable for application assistance of any kind. Customers may use WE's assistance and product recommendations for their applications and design. The responsibility for the applicability and use of WE Products in a particular customer design is always solely within the authority of the customer. Due to this fact it is up to the customer to evaluate and investigate, where appropriate, and decide whether the device with the specific product characteristics described in the product specification is valid and suitable for the respective customer application or not.

The technical specifications are stated in the current data sheet of the products. Therefore the customers shall use the data sheets and are cautioned to verify that data sheets are current. The current data sheets can be downloaded at [www.we-online.com](http://www.we-online.com). Customers shall strictly observe any product-specific notes, cautions and warnings. WE reserves the right to make corrections, modifications, enhancements, improvements, and other changes to its products and services.

WE DOES NOT WARRANT OR REPRESENT THAT ANY LICENSE, EITHER EXPRESS OR IMPLIED, IS GRANTED UNDER ANY PATENT RIGHT,

COPYRIGHT, MASK WORK RIGHT, OR OTHER INTELLECTUAL PROPERTY RIGHT RELATING TO ANY COMBINATION, MACHINE, OR PROCESS IN WHICH WE PRODUCTS OR SERVICES ARE USED. INFORMATION PUBLISHED BY WE REGARDING THIRD-PARTY PRODUCTS OR SERVICES DOES NOT CONSTITUTE A LICENSE FROM WE TO USE SUCH PRODUCTS OR SERVICES OR A WARRANTY OR ENDORSEMENT THEREOF.

WE products are not authorized for use in safety-critical applications, or where a failure of the product is reasonably expected to cause severe personal injury or death. Moreover, WE products are neither designed nor intended for use in areas such as military, aerospace, aviation, nuclear control, submarine, transportation (automotive control, train control, ship control), transportation signal, disaster prevention, medical, public information network etc. Customers shall inform WE about the intent of such usage before design-in stage. In certain customer applications requiring a very high level of safety and in which the malfunction or failure of an electronic component could endanger human life or health, customers must ensure that they have all necessary expertise in the safety and regulatory ramifications of their applications. Customers acknowledge and agree that they are solely responsible for all legal, regulatory and safety-related requirements concerning their products and any use of WE products in such safety-critical applications, notwithstanding any applications-related information or support that may be provided by WE.

CUSTOMERS SHALL INDEMNIFY WE AGAINST ANY DAMAGES ARISING OUT OF THE USE OF WE PRODUCTS IN SUCH SAFETY-CRITICAL APPLICATIONS.

### USEFUL LINKS



Application Notes

[www.we-online.com/app-notes](http://www.we-online.com/app-notes)



REDEXPERT Design Tool

[www.we-online.com/redexpert](http://www.we-online.com/redexpert)



Toolbox

[www.we-online.com/toolbox](http://www.we-online.com/toolbox)



Produkt Katalog

[www.we-online.com/products](http://www.we-online.com/products)

### CONTACT INFORMATION

[appnotes@we-online.com](mailto:appnotes@we-online.com)

Tel. +49 7942 945 - 0



Würth Elektronik eiSos GmbH & Co. KG  
Max-Eyth-Str. 1 · 74638 Waldenburg · Germany

[www.we-online.com](http://www.we-online.com)

