

Step 1. Prepare connector components



Body



Bolt



Washer

Step 2. Put body on the PCB and mounting holes aligned with the PCB through holes.

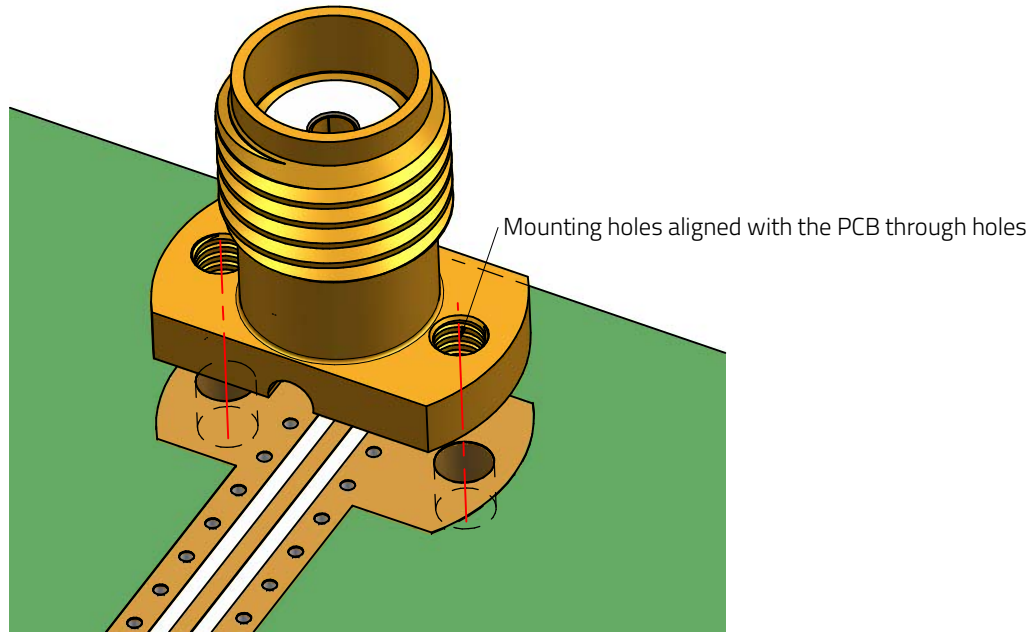

Step 3. Using 0.9 N*m torque force to screw the bolt with washer to the bottom of PCB..

⚠ Do not apply excessive force, it might damage connector and PCB.

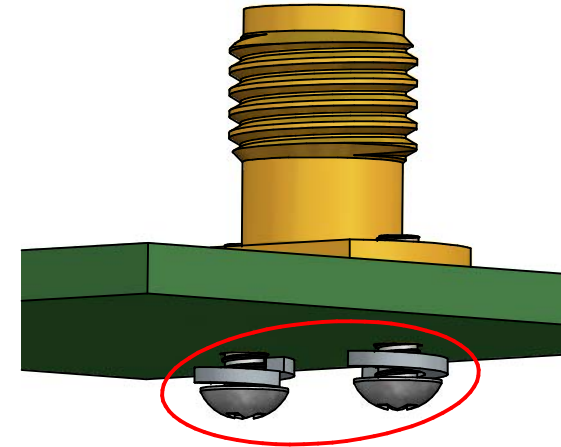

Würth Elektronik eiSos GmbH & Co. KG
 EMC & Inductive Solutions
 Max-Eyth-Str. 1
 74638 Waldenburg
 Germany
 Tel. +49 (0) 79 42 945 - 0
 www.we-online.com
 eiSos@we-online.com

CREATED AK	CHECKED OTs		
DESCRIPTION Assembly instructions 603 128 721 125 45			
REVISION 001.002	STATUS Valid	DATE 2023-09-12	BUSINESS UNIT eiCan