

Spezifikation für Freigabe / specification for release

Kunde / customer : **Preliminary**
 Artikelnummer / part number : **760871834**
 Bezeichnung : **Netzteil-Übertrager WE-UNIT**
 description : **Off-line transformer WE-UNIT**



DATUM / DATE : 2010-04-16

A Mechanische Abmessungen / dimensions :

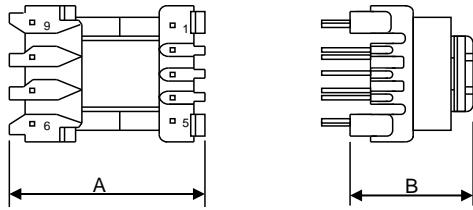

	E16/8/5	
A	25.0 max.	mm
B	16.5 max.	mm
C	20.5 max.	mm
D		mm
E		mm

● = Marking Pin 1

B Elektrische Eigenschaften / electrical properties :

Eigenschaften / properties	Testbedingungen / test conditions		Wert / value	Einheit / unit	tol.
Induktivität / inductance	100 kHz / 0,1 V	L_0	570.0	μH	$\pm 10\%$
Windungszahlverhältnis / turns ratio	N1:N2:N3:N4:N5	TR	32:1:0.66:2:4		$\pm 3\%$
DC-Widerstand N1 / DC-resistance N1	@ 20°C	R_{DC1}	1.7	Ω	max.
DC-Widerstand N2 / DC-resistance N2	@ 20°C	R_{DC2}	12.0	$\text{m}\Omega$	max.
DC-Widerstand N3 / DC-resistance N3	@ 20°C	R_{DC3}	9.6	$\text{m}\Omega$	max.
DC-Widerstand N4 / DC-resistance N4	@ 20°C	R_{DC4}	24.0	$\text{m}\Omega$	max.
DC-Widerstand N5 / DC-resistance N5	@ 20°C	R_{DC5}	210.0	$\text{m}\Omega$	max.
Sättigungsstrom N1 / saturation current N1	dL/L=20%	I_{sat}	tbd	A	typ.
Streuinduktivität / leakage inductance	100 kHz / 0,1V rest shorted	L_s	18.0	μH	max.
Hochspannung / hipot test	3mA, 1s N1, N4 => N2, N3	HV	4.0	kV	

C Lötpad / soldering spec. :

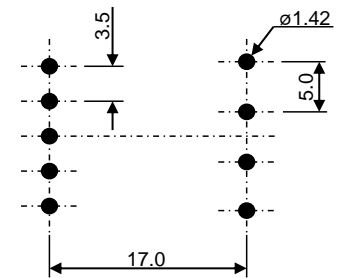

D Prüfgeräte / test equipment :

WK3260B für / for L und / and R

E Testbedingungen / test conditions :

Luftfeuchtigkeit / humidity: 33%
 Umgebungstemperatur / temperature: +20°C

F Werkstoffe & Zulassungen / material & approvals :

Basismaterial / base material: Ferrit/ ferrite
 Spulenkörper / Bobbin: UL-V0
 Draht / wire: 2UEW-F 155°C / TRW (F)
 Kontaktmaterial / contact plating: Cu-Ni-Sn
 Tränklack / Varnish: V1630FS or equiv.

G Eigenschaften / general specifications :

Betriebstemp. / operating temperature: -40°C - + 125°C
 Umgebungstemp. / ambient temperature: -40°C - + 85°C
 It is recommended that the temperature of the part does not exceed 125°C under worst case operating conditions.
 Schaltfrequenz / Switching frequency: 50 kHz
 Bauteil für Netzanwendung / Off-line transformer

Freigabe erteilt / general release:	Kunde / customer			
.....			
Datum / date	Unterschrift / signature			
	Würth Elektronik			
.....			
Geprüft / checked	Kontrolliert / approved	TBr	Revision 00	2010-04-16
		Name	Änderung / modification	Datum / date

Würth Elektronik eiSos GmbH & Co.KG

D-74638 Waldenburg · Max-Eyth-Straße 1 - 3 · Germany · Telefon (+49) (0) 7942 - 945 - 0 · Telefax (+49) (0) 7942 - 945 - 400
<http://www.we-online.com>

Spezifikation für Freigabe / specification for release

Kunde / customer : Preliminary
 Artikelnummer / part number : **760871834**
 Bezeichnung : **Netzteil-Übertrager WE-UNIT**
 description : **Off-line transformer WE-UNIT**

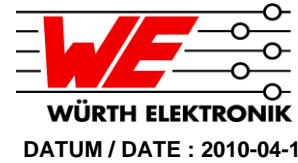

H Schaltbild / Schematics

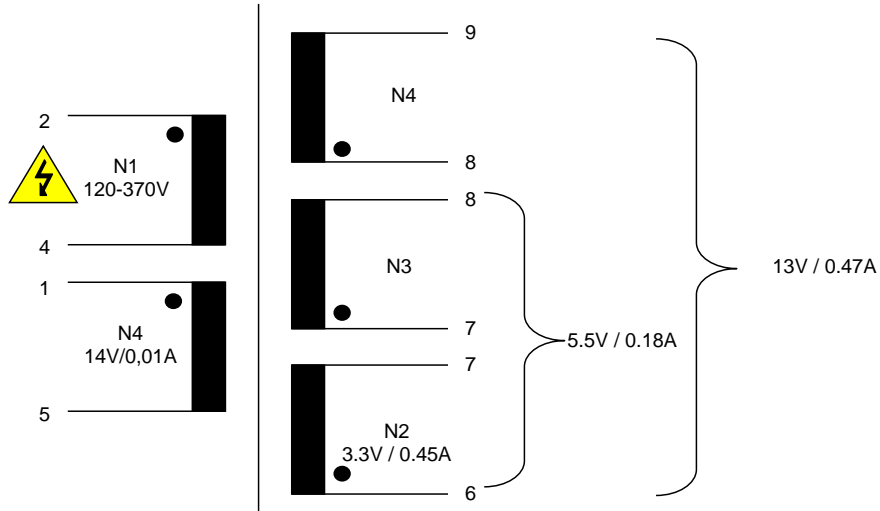

Freigabe erteilt / general release:	Kunde / customer			
Datum / date	Unterschrift / signature			
	Würth Elektronik			
Geprüft / checked	Kontrolliert / approved	TBr	Revision 00	2010-04-16
		Name	Änderung / modification	Datum / date

This electronic component has been designed and developed for usage in general electronic equipment. Before incorporating this component into any equipment where higher safety and reliability is especially required or if there is the possibility of direct damage or injury to human body, for example in the range of aerospace, aviation, nuclear control, submarine, transportation, (automotive control, train control, ship control), transportation signal, disaster prevention, medical, public information network etc, Würth Elektronik eiSos GmbH must be informed before the design-in stage. In addition, sufficient reliability evaluation checks for safety must be performed on every electronic component which is used in electrical circuits that require high safety and reliability functions or performance.

Würth Elektronik eiSos GmbH & Co.KG

D-74638 Waldenburg · Max-Eyth-Straße 1 - 3 · Germany · Telefon (+49) (0) 7942 - 945 - 0 · Telefax (+49) (0) 7942 - 945 - 400
<http://www.we-online.com>