

REDCUBE TERMINALS

PRESS-FIT BOARD-TO-BOARD

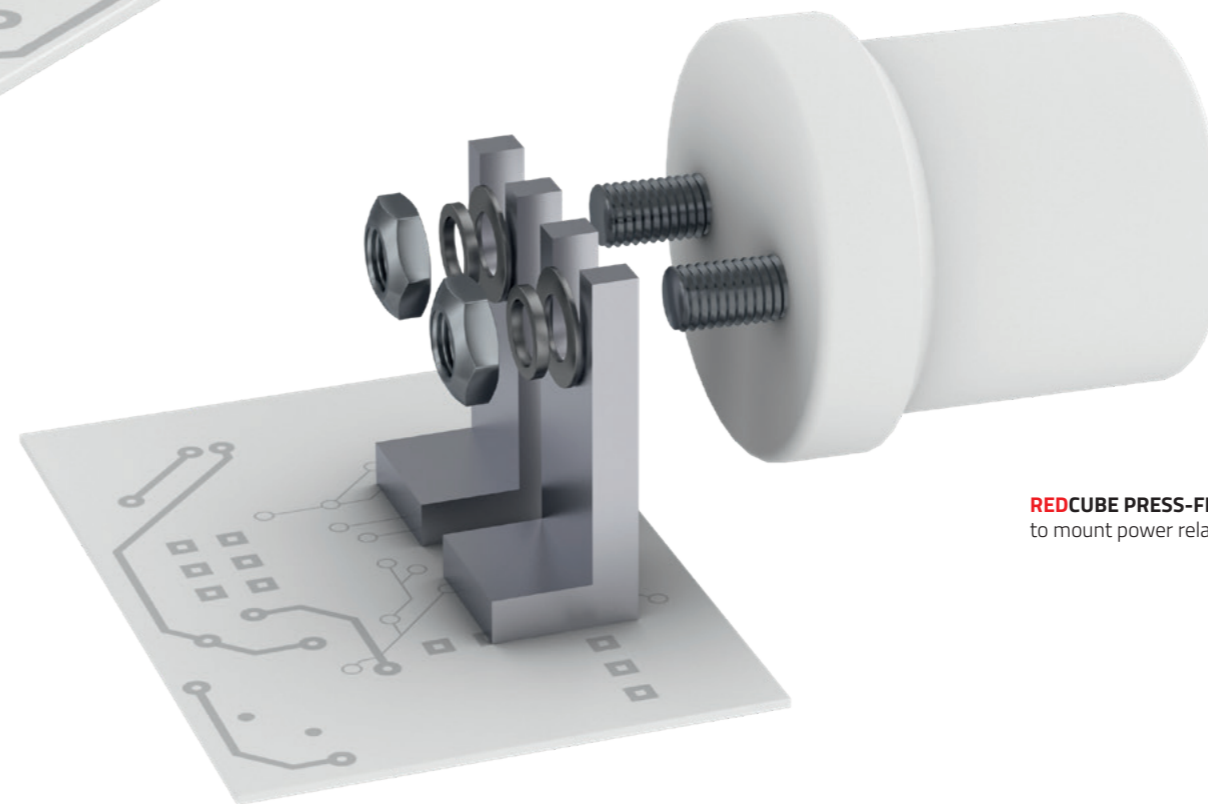

Special Features

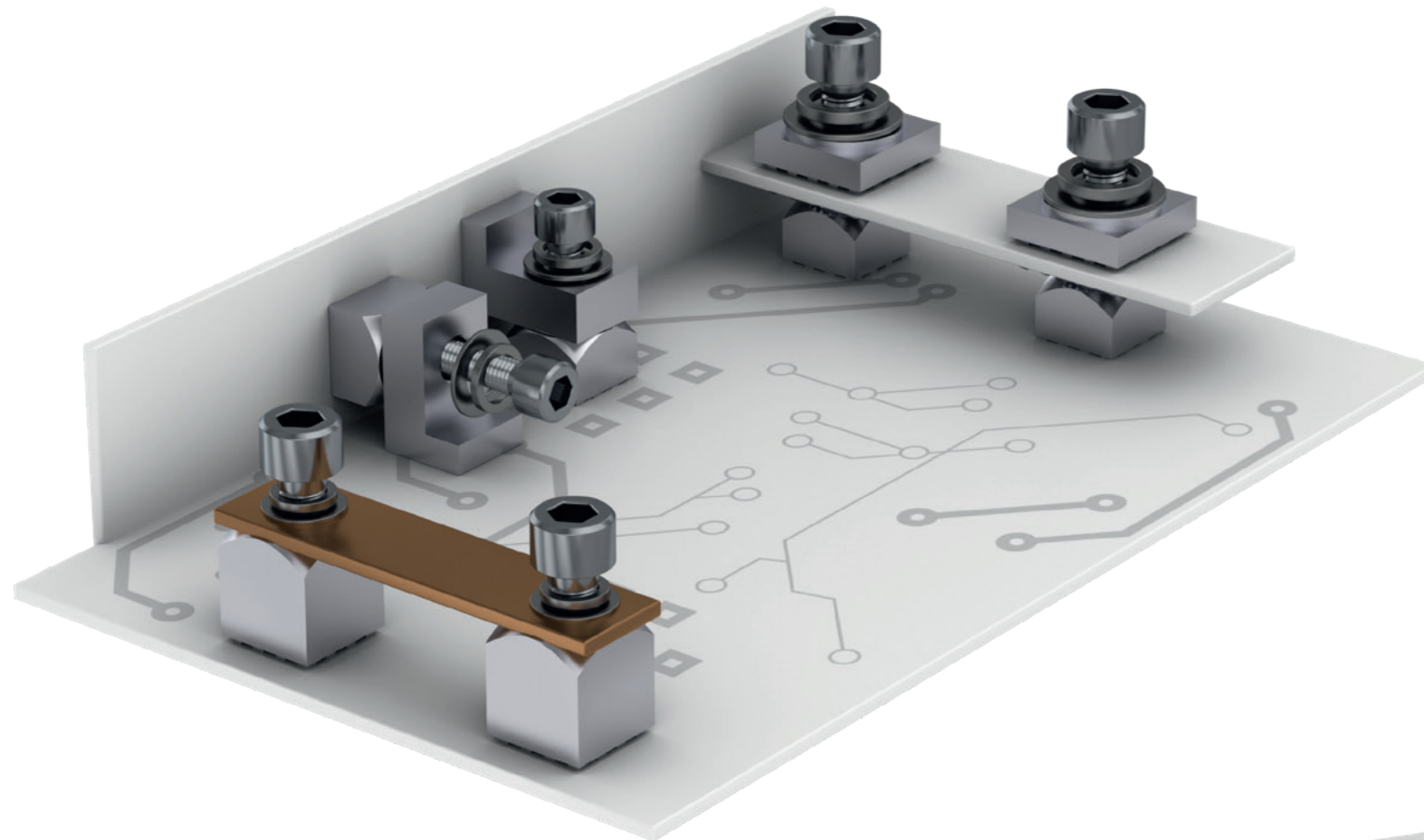
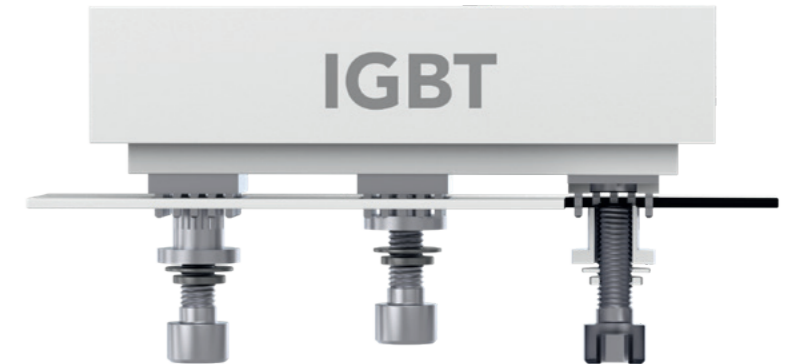

Two-part REDCUBE PRESS-FIT to mount IGBT

REDCUBE PRESS-FIT right angled with U-shape to mount power relay

Features & Benefits

- REDCUBE PRESS-FIT allows high current board-to-board solutions up to 500 A. For applications with current up to 85 A, REDCUBE Press-Fit can be combined with REDCUBE SMT & THR versions.
- Mounting of a bus bar for increasing the current-carrying capacity is also possible by using REDCUBE PRESS-FIT.
- REDCUBE PRESS-FIT can be used for a solid high current connection of relay contractor or IGBT. Horizontal or vertical mounting on the PCB is possible.

Available Products

- WP-BUCF, WP-BUTR, WP-BUFU: Internal thread M3 to M10
- WP-SHFU: External thread M3 to M10
- WP-RAFU, WP-RATR: Right angled M3 to M10
- WP-RAFU: Right angled U-Shape ϕ 3.3
- WP-TGCF, WP-TGTR, WP-TPSE: Two-part M3 to M8; ϕ 3.2 to 10.5 mm
- Customized parts possible on request
- Rated current up to 500 A (+20 °C)

