

APPLICATION NOTE

ANP045 | Behind the Magic of High Frequency SMT Chip Bead Ferrites



Joanne Wu, Mohamed Koobar

1. INTRODUCTION

Technology is advancing at a tremendous rate and the next generation of devices are shifting towards wireless applications. The movement towards higher frequency, into the gigahertz range has begun and more knowledge of components in these applications is desired. EMC continues to grow in importance and there is a demand to know the characteristics of EMC components used beyond their current typical application range. The goal of this article is to explain the different properties between multilayer ferrite beads in high frequency (**WE-CBF HF**) and standard multilayer ferrite beads (**WE-CBF**), as well as a new methodology developed at Würth Elektronik for the measurement of DC bias at high frequencies. Lastly, some uncommon applications, where the WE-CBF HF high frequency series are a suitable alternative to traditional design topologies are shown.

Chip bead ferrites are one of the most used components for suppressing high frequency noise in the electronics industry. They are passive components with a high attenuation over a wide frequency range, and at the same time do not influence the useful component of the signal. They are commonly connected in series with the power supply or signal source. Nevertheless, improper use of the ferrite bead in the system can degrade the overall EMI suppression capability.

2. EQUIVALENT CIRCUIT MODELLING

Ferrite beads can have different characteristics at different frequencies. These can be roughly separated into three regions: inductive, resistive and capacitive characteristics (Figure 1). At its self-resonating frequency (SRF), the ferrite bead performs as a resistor, impeding high frequency signals and dissipating the power as heat.

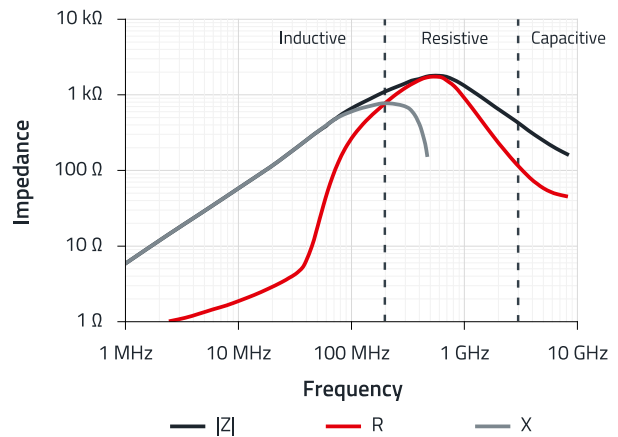

Figure 1: Impedance curve of WE-CBF HF (742841160).

The intended use of ferrite beads for EMI applications is, that the component must be in the resistive region over the frequency range where the noise needs to be attenuated. Parasitic elements inside the bead drastically affect the performance as a function of frequency. In order to take into consideration these parasitic elements, the equivalent circuit is modeled in the following topology consisting of an inductance (L), parallel capacitance (C_{PAR}), parallel resistance (R_{AC}) and series resistance (R_{DC}) (Figure 2).

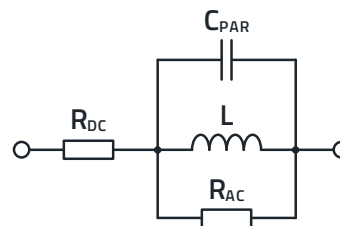

Figure 2: Equivalent circuit model.

This is frequently used in simulations to model a ferrite bead, and this model will be used to explain how these parasitic parameters influence the impedance curve.

APPLICATION NOTE

ANPO45 | Behind the Magic of High Frequency

3. COMPARISON WE-CBF HF AND WE-CBF SERIES

The Würth Elektronik multilayer ferrite bead family is categorized in different series, depending on their intended application, the shape of the impedance curve, core material and structure of the internal windings. In response to the movement towards operating at higher frequencies, Würth Elektronik has developed the **WE-CBF HF** "SMT EMI Suppression Ferrite Bead" (High Frequency) series. Here a comparison between the standard series **WE-CBF** and the high frequency series WE-CBF HF will be explored. This series is specially fabricated to increase performance, which means higher impedance and lower parasitic capacitance at higher frequencies.

A key factor in the electrical behavior of multilayer ferrite beads at different frequencies is the construction direction of the windings and the internal design. The inner structure not only influences the frequency response but also the impedance the chip beads can produce. Horizontal windings (Figure 3) and vertical windings (Figure 4) have a fundamental effect on the performance of ferrite beads, even within the same case size.

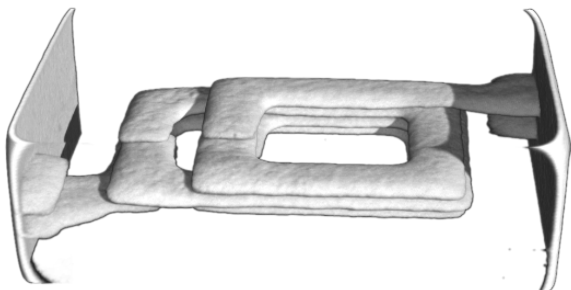

Figure 3: CT of inner structure of chip bead ferrites (WE-CBF).

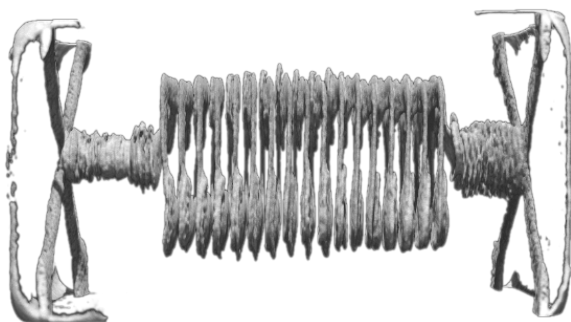

Figure 4: CT structure of vertical ferrite bead (WE-CBF HF).

To understand the performance, the formation of parasitics within the structure is analyzed.

In order to understand how the construction and parasitics influence the electrical properties, the association between this and the impedance of a chip bead is identified. The relationship to the overall impedance is described by applying the impedance equation (1).

$$|Z| = \sqrt{R^2 + (X_L - X_C)^2} \quad (1)$$

The main influence from parasitic elements come from the reactive part of the equation. The lower the capacitive reactance (X_C) and the more inductive reactance (X_L) found in the total reactance, the higher the magnitude of the impedance.

The basic CBF design has horizontal windings layered in the vertical direction (Figure 3). This makes them easier to fabricate and reduces production costs. However, this type of structure yields a lower impedance with an impedance peak at a lower frequency than for example the WE-CBF HF, which has vertical windings layered in the horizontal direction (Figure 4). The horizontal structure is limited to the number of windings due to the standard height of a SMT ferrite. On the other hand, the vertical structure utilizes the length dimension to increase the winding layers.

In a horizontal winding, every winding runs between the connection terminals, creating a small parasitic capacitance (C_P) between the winding and terminal (Figure 5 left). Each winding creates layers of: Terminal – parasitic capacitance – winding – parasitic capacitance – terminal structure. These layers contribute to the parasitic as the subcircuits accumulate in parallel, creating a sum up of capacitances in which will decrease the overall reactance (2).

$$C_{\text{PARALLEL}} = C_1 + C_2 + C_3 + \dots + C_n \quad (2)$$

In the ferrite bead WE-CBF HF, the silver layer is formed like a wound air coil, looping steadily from one terminal to the other (Figure 5 right). This causes parasitic capacitance to be present between the loops (inter-winding capacitance) and at each end terminations.

APPLICATION NOTE

ANPO45 | Behind the Magic of High Frequency

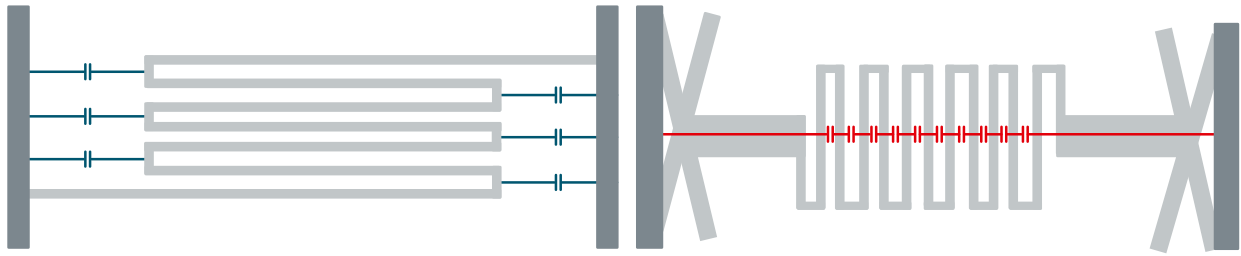

Figure 5: The parasitic capacitances of the **WE-CBF** (left) and **WE-CBF HF** (right).

As the parasitic capacitance is in series with their neighbor, the overall capacitance is the inverse of the sum of all inverse capacitances (3).

$$\frac{1}{C_{SERIES}} = \frac{1}{C_1} + \frac{1}{C_2} + \frac{1}{C_3} + \dots + \frac{1}{C_n} \quad (3)$$

Consequently, the total parasitic capacitance is just a fraction of the parasitic capacitance of that found in the ferrite bead WE-CBF. This has the effect of increasing the SRF and therefore the possible operating frequency range is shifted to higher frequencies.

Consider the WE-CBF (742792693) compared with the WE-CBF HF (742861210), where both are size 0603 of type wide band and have a peak Z_{MAX} around 2.2 k Ω (Figure 6 left). After the SRF the ferrite bead becomes capacitive and this effect of parasitic capacitances can be observed from their reactance behavior as the value is no longer rising but falling (Figure 6 right).

From the WE-CBF, the parasitic capacitance becomes dominant at 100 MHz, while the WE-CBF HF dominates at 450 MHz, shifting nearly five times higher in frequency than the standard part.

Not only being able to have the SRF reach a higher frequency region, in this case it also allows the use of a **WE-CBF HF** over a wider frequency range than the standard **WE-CBF** series. For example, a request for a filter with an impedance of 500 Ω , the WE-CBF has a range from 30 MHz to 300 MHz, while the WE-CBF HF has a larger range from 70 MHz to 2500 MHz, permitting a much wider operating bandwidth (Figure 7). With the same size, type and similar electrical characteristics, a wider usable bandwidth may mean less EMI issues in this region.

Summarized, the design of the inner structure windings contribute to the total parasitic capacitance. They sum up to be either in parallel or series and this can lead to achieving a SRF located in a higher frequency region. Furthermore, the bandwidth also shifts up in frequency and consequently the range of use is higher and may be wider too.

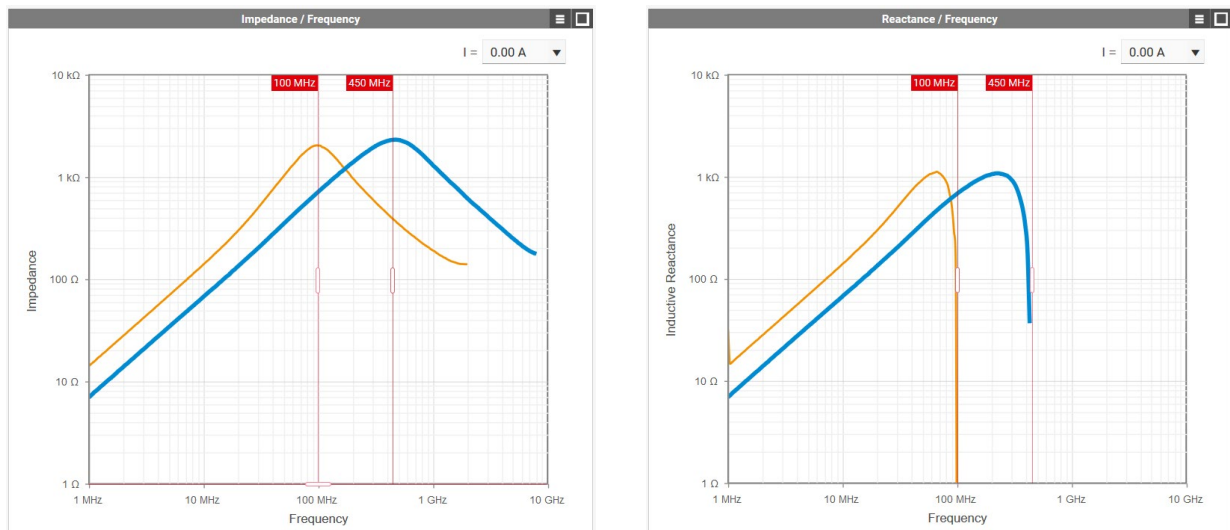

Figure 6: Interactive chart in **REDEXPERT** comparing the impedance (left) and reactive part (right) of WE-CBF 742792693 (orange) and WE-CBF HF 742861210 (blue) with 0 A DC bias current.

APPLICATION NOTE

ANPO45 | Behind the Magic of High Frequency

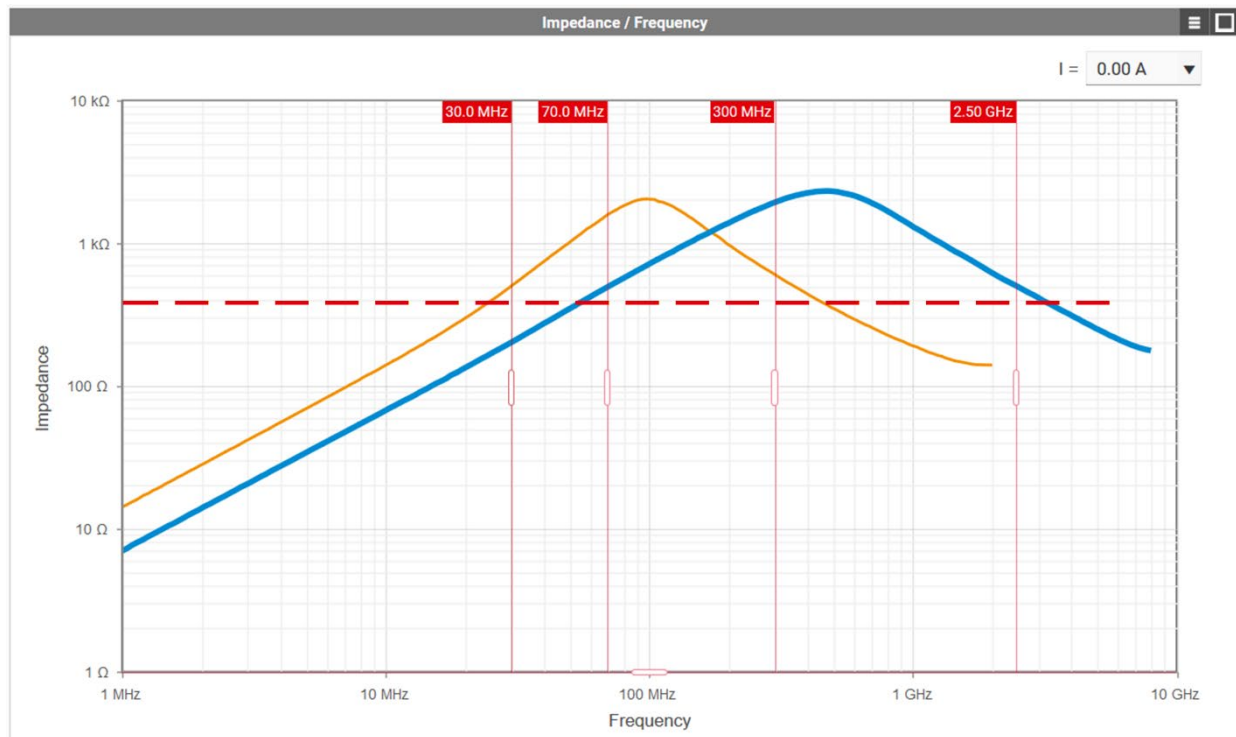

Figure 7: Interactive chart in **REDEXPERT** comparing the impedance of WE-CBF 742792693 (orange) and WE-CBF HF 742861210 (blue) with 0 A DC bias current.

4. THE EFFECT OF TEMPERATURE AND DC BIAS CURRENT

The optimal selection of a multilayer ferrite to suit the need of a specific application requires, among other parameters, defining the operational temperature and DC current. External influences cause the multilayer ferrite to behave differently. For example a change of temperature can modify the magnetization state of a ferrite bead. In addition, the so called DC bias effect is the current-dependence of general ferrite materials. The DC current can also be correlated to the operating temperature of the component, as the part generates heat due to the current and therefore influences its electrical characteristics.

Magnetic materials have a maximum useful operating temperature. At a certain point, the magnetic permeability of a material decreases strongly with increasing temperature (Figure 8). At temperatures where the thermal energy is greater than the energy supplied by the external magnetic field, the magnetic dipoles (elementary magnets) become difficult to align preventing the formation of a magnetic field. This critical temperature is called the Curie temperature. At temperatures above the Curie temperature, the ferrite loses its permeability (where it drops to $\mu = 1$) and becomes paramagnetic (weakly magnetized).

With this knowledge, the alignment can be destroyed by heating beyond the Curie temperature or through other methods of thermal exposure, shock and even strong magnets.

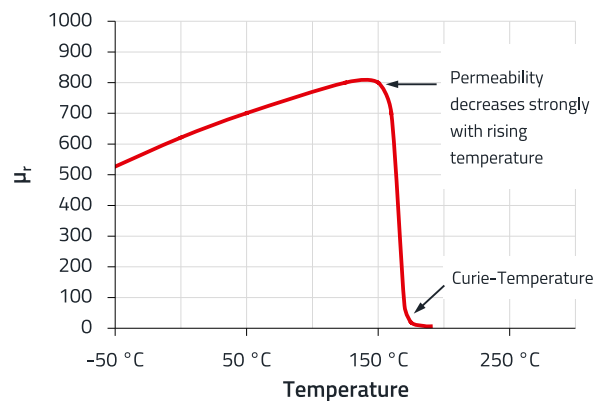

Figure 8: Curie temperature.

This effect is reversible. When the temperature cools below the Curie temperature the ferrite regains its permeability and becomes ferromagnetic again. Using this sequence of events will allow the ferrite beads to be measured in a consistent manner, by aligning the magnetic dipole to a remanent free initial state.

APPLICATION NOTE

ANP045 | Behind the Magic of High Frequency

Ferrite beads are made to dissipate heat, however the more it dissipates the higher the operating temperature it reaches. Figure 9 shows a typical temperature profile of a chip bead with a curie temperature above 180°C, where the measurement is carried out from -55°C to 160°C.

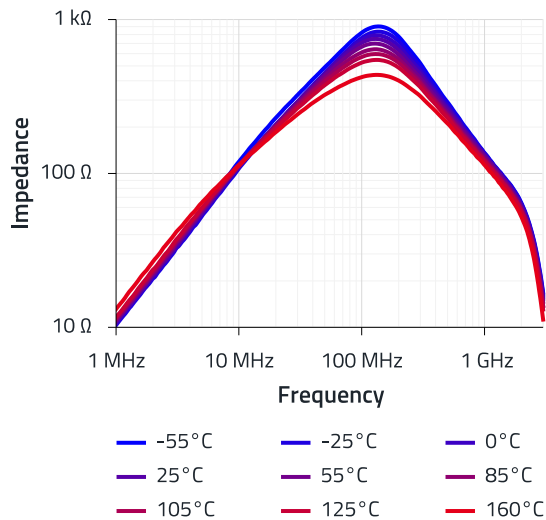

Figure 9: Impedance graph of WE-CBF [742792040](#) with temperature.

As depicted, the higher the temperature of the component, the more the impedance is shifted down, becoming more saturated. The optimal operating temperature would be to stay as close to the ambient temperature (~20°C to 25°C). Engineers should take this and environmental influences into consideration when designing applications.

Besides the temperature, multilayer ferrites are always operated under current bias; therefore, measurements with DC bias give essential information about the components behavior during operation. The impedance profile is graphed to depict the influence of various DC bias current conditions (Figure 10).

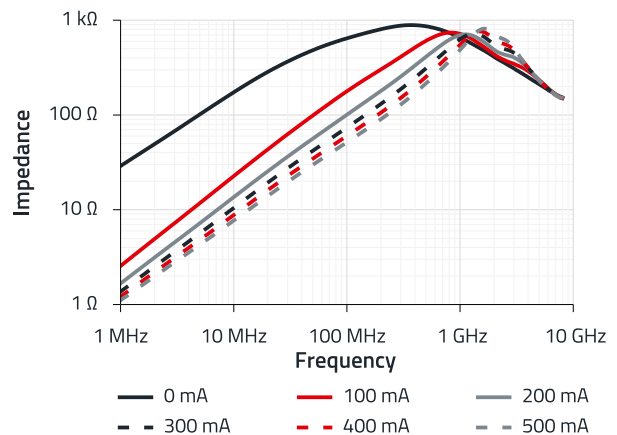

Figure 10: Comparison of the WE-CBF HF [742861160](#) under differing DC Bias conditions.

As the applied current increases, the internal core material moves towards saturation, causing a drop in inductance. This saturation is due to the maximum magnetic dipole alignment and will change the permeability (hence impedance) of the ferrite. As shown in the low frequency region, the biasing current has a more drastic effect compared to the high frequency region.

As the DC bias current increases, the inductance decreases, however the parasitic capacitance stays the same. This leads to the SRF peak shifting right towards higher frequencies. In addition, the damping resistance also becomes lower and moves right, causing the quality factor to increase. In this scenario, SMT ferrites produce sharper and higher SRF peaks. Lastly, it can be seen that the impedance converges towards one point at the end of this frequency range (WE-CBF HF [742841160](#) at 8 GHz). This is caused by the ferromagnetic effect, dominating up to the SRF. Above the SRF the ferromagnetic effect is still present, however it is hidden by the resonance and capacitive effects. The ferromagnetic properties lose their influence with decreasing permeability and become paramagnetic. In this state, the bead physically acts like a wire coil at its capacitive state (due to parasitic capacitance).

The amount of magnetic field strength which causes saturation differs depending on the material used for the core. For example, Nickel-Zinc (NiZn) is a commonly used core material and displays ferromagnetic properties. Below, two WE-CBF HF parts that have similar properties but different core material are compared.

APPLICATION NOTE

ANPO45 | Behind the Magic of High Frequency

Both parts are defined in the datasheet at 100 MHz with a typical impedance of 600 Ω at 0 A DC bias current (Figure 11).

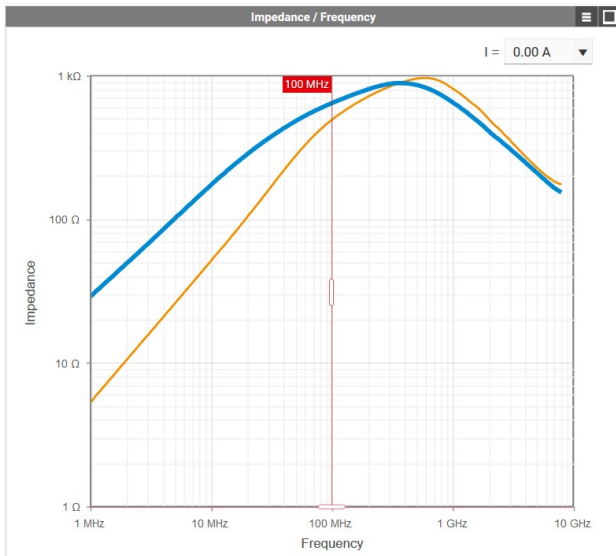

Figure 11: Interactive chart in **REDEXPERT** comparing WE-CBF HF 742861160 (blue) and 742863160 (orange) with 0 mA DC bias current.

As the components each have different saturation levels, when the ferrite beads are exposed to a DC bias current of 100 mA, both parts saturate, and impedance decreases rapidly as seen in Figure 12.

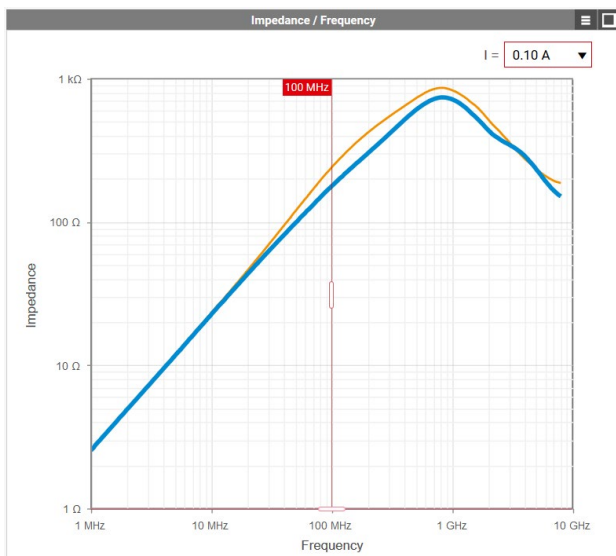

Figure 12: Interactive chart in **REDEXPERT** comparing WE-CBF HF 742861160 (blue) and 742863160 (orange) with 100 mA DC bias.

However, the **742863160** (orange curve) has a higher saturation level and can maintain its impedance levels compared to a decrease in impedance from **742861160** (blue curve). At the 100 MHz frequency marker, a clear drop in value is seen after 100 mA bias current is applied as noted between

Figure 11 and Figure 12. It can be observed that depending on the material, there are different responses to saturation current.

This chapter demonstrates that influence from temperature and DC bias are key parameters for the selection of the correct component. The impedance graphs of chip bead ferrites can be found in the respective datasheet with a DC bias current graph showing key current values. However, Würth Elektronik's measurement based online design platform **REDEXPERT**, can be used to easily determine the impedance and other electrical characteristics of any chip bead ferrite at any operating frequency and DC bias current. Alternatively, incorporating a chip bead ferrite into a simulated design for evaluation is possible with the availability of S-parameters and SPICE simulation models.

5. STATE OF THE ART MEASUREMENT METHODOLOGY

The common industrial impedance analyzers and DC bias test fixtures for SMT devices have reached their frequency measurement limitations. At frequencies above 1 GHz, measurements are inherently unstable or not possible due to the measuring method. In addition, an external supply of up to 5 A is the maximum applicable DC biasing current available. This limits the information provided in data sheets for designers wanting to know the profile of a multilayer ferrite bead.

Considering this, Würth Elektronik eiSos has developed a new and enhanced measurement technique for SMT components. With this patented technique, it is possible to measure impedances for frequencies higher than 3 GHz with DC bias currents up to 20 A. To achieve frequencies beyond 3 GHz, an impedance analyzer is no longer sufficient and a Vector Network Analyzer (VNA) becomes more advantageous. This allows more information to be provided in ferrite bead data sheets and not be restricted from the measurement setup.

The impedance analyzer DC bias test fixture utilizes a push and hold action on the ferrite bead onto gold electrode contact pads to measure the values. However, this setup has low repeatability as the connections with the termination is not fixed. In contrast, the new design minimizes this error completely by providing a solid connection, where the device under test (DUT) is soldered down and tested on a PCB. In a real-world application, ferrite beads are used soldered onto a PCB; therefore, this measurement method provides a more realistic and equivalent test environment. In addition, to keep

APPLICATION NOTE

ANPO45 | Behind the Magic of High Frequency

measurement consistency, the components are put through the reflow oven past the Curie temperature of the material to solder the parts onto a PCB. This is according to the soldering profile JEDEC J-STD-020E at 260°C. Correlating to the influence of temperature (Section 4), this forces the elementary magnets to align to a remanent initial free state before the start of a measurement. To prove the measurement data up to 3 GHz can be replicated with the new measurement setup, the WE-CBF HF series was measured and compared. The results of WE-CBF HF (742841160) obtained using an impedance analyzer up to 3 GHz and VNA up to 8 GHz are nearly identical, as illustrated in Figure 13.

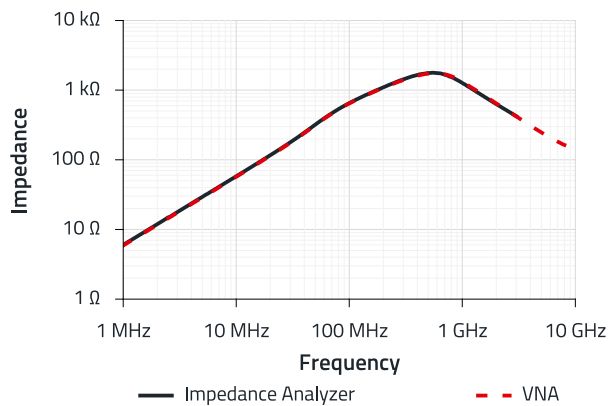

Figure 13: Graph showing a measurement of WE-CBF HF (742841160) from the impedance analyzer and VNA.

This confirms the validity of the results from the new patented technique.

The block diagram in Figure 14 depicts the design of the new test fixture and measurement setup with test circuit design.

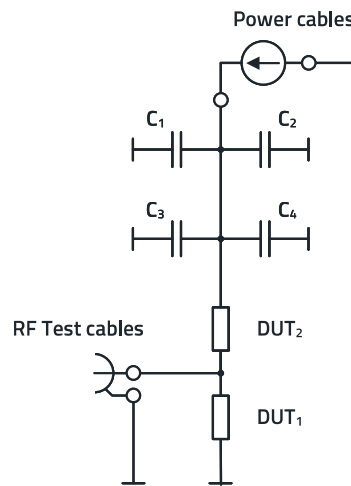
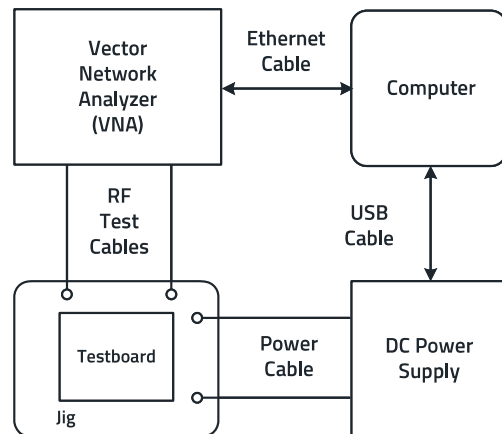

Figure 14: Würth Elektronik's enhanced test setup and circuit design.

Here the VNA and power supply are remotely controlled to collect the measured data and adjust the DC current. The internal DC bias power available with conventional measurement instruments is limited to a few amperes. Consequently, it is unable to provide currents of more than 5 A. The new jig allows an external power supply to be connected, where the limits are bound by the maximum current of the power supply device and the heating limit of the PCB.

APPLICATION NOTE

ANP045 | Behind the Magic of High Frequency

This measurement methodology allows valuable information in the high frequency region and high DC bias applications to be provided for better understanding of the component's performance. A major difference of this setup is being able to consider the environmental settings and procedures. Before obtaining the electrical properties, close to reality environment of the DUT, like soldering the part onto a PCB, is now included in the process leading up to the measurement (Figure 15).

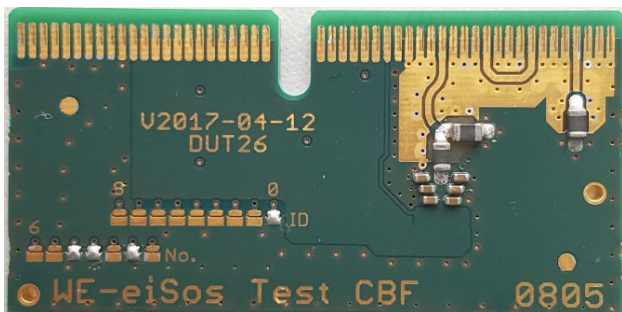

Figure 15: Test board of a SMT ferrite in case size 0805.

6. APPLICATIONS

Many EMC problems from electronic devices can be solved with a chip bead ferrite solution in the EMI signal path. Numerous Internet of Things (IoT) applications have wireless integrated into the devices and Würth Elektronik provides multilayer chip bead ferrites to ensure no EMI problems are generated. There are many applications where a ferrite bead is commonly used, these include:

- Suppression on signal lines
- High frequency RF modules (In the V_{CC} lines to make sure no EMI problems are generated)
- Filtering harmonics for mobile communication
- Data line filtering in high-speed bus systems (CAN, USB, Video, RS232, Wireless LAN)
- Filtering circuits
- Impedance matching circuits
- DC biasing

However, it is interesting to show different perspectives of using a chip bead in different application scenarios. Here we introduce uncommon applications of interest where WE-CBF HF is a suitable alternative to components that are traditionally in these circuit designs.

6.1 Broadband Amplifier 5 MHz – 7 GHz

Broadband amplifiers are often needed in receiving applications when using antennas, to reproduce a wide range of signals with low noise. Bias network is one of the critical aspects in RF circuit design. It determines the amplifier's performance over temperature as well as DC bias conditions. The DC voltages applied in an amplifier cannot be applied directly. Therefore, a high impedance component is used to ensure the complete RF signal passes through the device and not back through the DC bias circuit.

The current bias is seen as a high impedance element to the RF signal, allowing most of the information to pass through the device. Hence supplying a stable current to the output. A standard inductor does not operate over a wide frequency range, having a smaller resistive area profile (roughly in the range of 200 MHz to 2 GHz only). For a standard wire wound ferrite, the parasitics begin to dominate resulting in capacitance and less inductance. An alternative to provide wide bandwidth for broadband use is to substitute the air coil inductor with **WE-CBF HF** ferrite beads at L_1 and L_2 (Figure 16 and Figure 17).

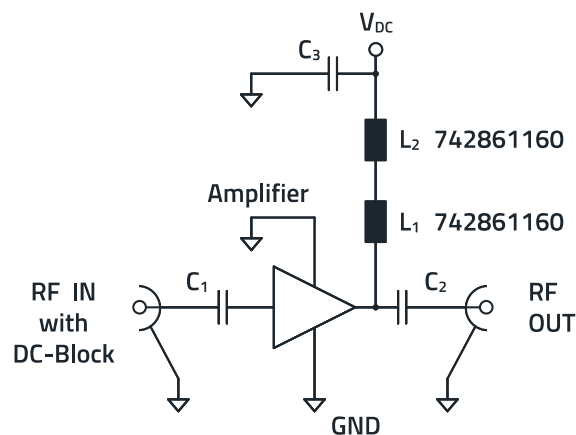

Figure 16: Gain amplifier circuit design.

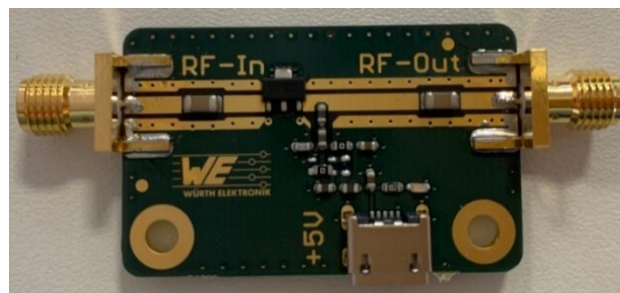

Figure 17: Gain amplifier test board with WE-CBF HF (742861160).

APPLICATION NOTE

ANP045 | Behind the Magic of High Frequency

High impedances in the power supply path above 200 Ω can drive the gain block and additionally for impedances lower than 200 Ω the RF signal at the output of the gain block will be attenuated.

The advantages of using a WE-CBF HF:

- Wide band of frequencies (broadband)
- Stable induction
- RF signal passes through to output

A more detailed examination of this application is provided in [ANP101](#).

6.2 Anti-aliasing filter for Analog-to-Digital-Converter (ADC)

It is usually necessary to place an anti-aliasing filter before an analog-to-digital-converter (ADC) to attenuate the unwanted higher frequency noise and signals. The common LC formation of a low pass filter (LPF) may have effects of under damping which creates a resonant peak at a frequency band around the switching frequency of the converter, consequently results in the amplification of unwanted switching noises. Using a ferrite bead in series with the inductor will dampen and smooth out the LPF response and additionally act as an impedance transformer.

The standard way to design a filter for an ADC includes RC topologies and LC topologies with or without using operational amplifiers (op-amp). As a first order filter, an RC filter produces a fall of -3 dB at its cut off and a steepness slope of 20 dB/decade step down frequency response which generally is not enough to provide a strong filtering system. An LC filter usually has low resistivity and high inductivity; as a result, minimal damping creates unwanted oscillation. Since an ADC does not have a standard resistive load; therefore, when a peak load occurs, the measure of this load can be identified as a resonating peak at the corner frequency.

Instead of attenuating noise, the resonance peak is a reason that causes the noise to amplify. Resistor and ferrite beads can be used to damp a system to reduce the amount of resonant peaking; since a ferrite bead still has a high Q factor, it acts like an inductor in the low frequency region (Section 2). The resistive part of a ferrite bead does not become dominant until reaching the megahertz range.

Therefore in general, the [WE-CBF HF](#) has higher inductance compared to [WE-CBF](#) even in low frequency regions. Due to their construction, a low cut off frequency is achievable (Figure 18).

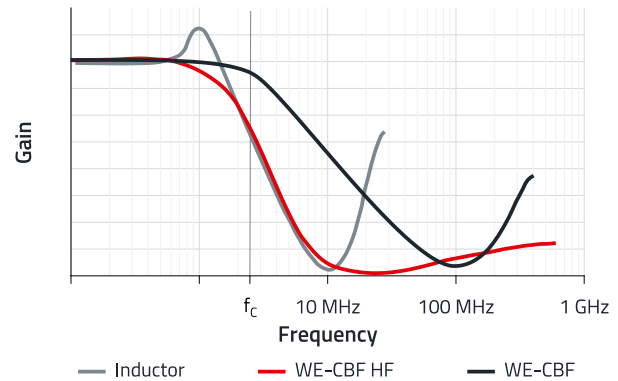

Figure 18: Gain response of a low pass filter for an inductor and ferrite beads.

The following circuit design with a WE-CBF HF will produce a cut off frequency slope twice the amount to 40 dB/decade and a filter drop of more than -3 dB (Figure 19).

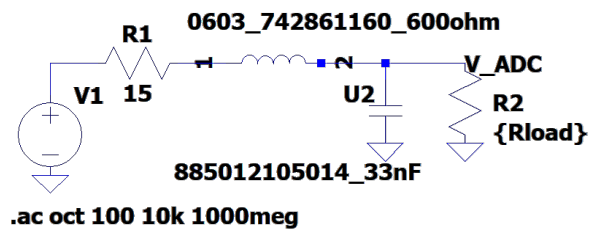

Figure 19: LT Spice model of an anti-aliasing filter with WE-CBF HF (742861160).

This suppresses the resonance peak at the corner frequency so that a smoother transition can occur.

The advantages of using an additional chip bead ferrite:

- 40 dB/decade ramp down frequency response
- Suppress the resonance peaking
- Takes less space and fewer components than an op-amp circuit design
- Overall filter design has lower cost

APPLICATION NOTE

ANPO45 | Behind the Magic of High Frequency

6.3 Terminating stub for log periodic dipole antenna (LPDA)

Log periodic dipole antennas (LPDA) are now used in many applications operating over a wide range of frequencies. LPDA consists of a number of dipole elements gradually increasing in length where the elements are spaced at intervals following a logarithmic function of the frequency. Printed LPDA layout is an alternative way of applying this antenna array using microstrip printed technology. Designing an antenna on a PCB has different considerations to take into account. For example, not only an accurate calculation of the length and distances of the element, but the compatibility of the microstrip line tracks to the PCB is just as important. In the design phase there may also be PCB size or material budget constraints.

When a higher front-to-back ratio at the lowest frequency is desired, the antenna feeder should include a high impedance termination stub (Figure 20).

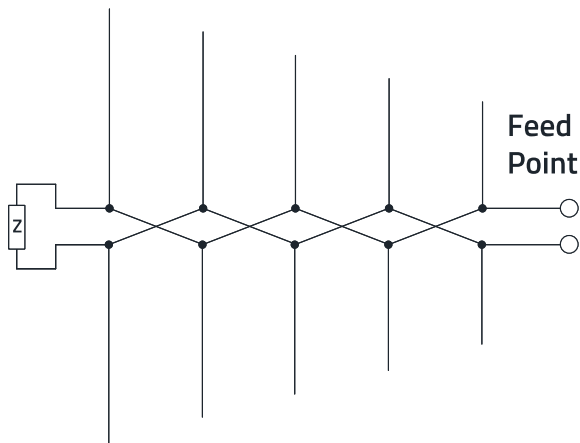

Figure 20: Diagram of a LPDA terminating with a high impedance.

This shorted stub acts as a reflector to ensure a match is provided to the antenna feeder. This length Z is a quarter of the longest element. Therefore, depending on the operating frequency and size, a suitable length is calculated.

Conventionally, the length of the antenna is used to transform the system to the frequency range to terminate, such as a quarter wave impedance transformer (since the length works at a specific narrow banded frequency), an alternative is to use a real component that also has high impedance in the frequency range.

An antenna with stub traditionally starts at the stub and the cut off is far from the stub (Figure 21).

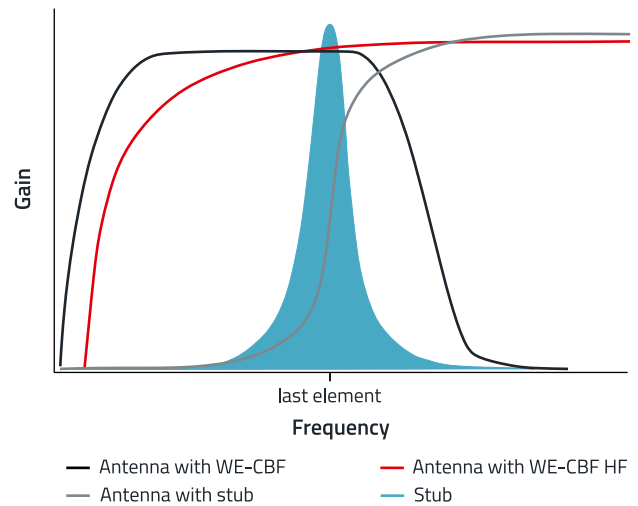

Figure 21: Gain over frequency of antenna with terminating stub.

Similarly, an antenna with a high impedance and high frequency chip bead operates before the stub and also has a cut off far from the stub. In contrast a ferrite bead with not enough impedance will cut off earlier near the stub, shortening the useable bandwidth.

For example, the WE-CBF HF ([742862160](#)) or ([742863147](#)) fulfill the requirements with its high impedance peak ranging from 100 MHz to 1 GHz. By using a ferrite bead, not only is the same size PCB kept by saving the space that would be occupied by the line transformation, the operative frequency range is also widened (Figure 22).



Figure 22: PCB of an LPDA with WE-CBF HF ([742862160](#)).

The advantages of using a **WE-CBF HF**:

- Wider operating frequency (lower frequency region)
- Smaller PCB size hence saves space
- Lower cost alternative

APPLICATION NOTE

ANP045 | Behind the Magic of High Frequency

7. SUMMARY

The WE-CBF HF is a component suitable for suppressing EMI at the higher frequencies commonly found in new and existing device technologies. The WE-CBF is still the component of choice when operating at lower frequencies. Additionally, a newly developed measurement technique for SMT components, providing an insight of its frequency behavior up to 8 GHz and applicable current up to 20 A. Lastly, due to the unique features of the WE-CBF HF, it can also be used in a range of applications not typically associated with chip bead ferrites.

Implementing the WE-CBF and WE-CBF HF in your design has never been easier with S-parameters and Spice models available via the Würth Elektronik website. Choose the perfect part and even order the samples directly via [REDEXPERT](#) or can be found in the WE-CBF HF SMT Ferrites Design Kit ([742841](#)). Additionally, all components are available ex-stock with no minimum MOQ. With the inclusion of the [WE-CBF](#) range, circuit designers now have even more flexibility in their ferrite bead selection, ensuring the right component is found for each application.

APPLICATION NOTE

ANP045 | Behind the Magic of High Frequency

IMPORTANT NOTICE

The Application Note is based on our knowledge and experience of typical requirements concerning these areas. It serves as general guidance and should not be construed as a commitment for the suitability for customer applications by Würth Elektronik eiSos GmbH & Co. KG. The information in the Application Note is subject to change without notice. This document and parts thereof must not be reproduced or copied without written permission, and contents thereof must not be imparted to a third party nor be used for any unauthorized purpose.

Würth Elektronik eiSos GmbH & Co. KG and its subsidiaries and affiliates (WE) are not liable for application assistance of any kind. Customers may use WE's assistance and product recommendations for their applications and design. The responsibility for the applicability and use of WE Products in a particular customer design is always solely within the authority of the customer. Due to this fact it is up to the customer to evaluate and investigate, where appropriate, and decide whether the device with the specific product characteristics described in the product specification is valid and suitable for the respective customer application or not.

The technical specifications are stated in the current data sheet of the products. Therefore the customers shall use the data sheets and are cautioned to verify that data sheets are current. The current data sheets can be downloaded at www.we-online.com. Customers shall strictly observe any product-specific notes, cautions and warnings. WE reserves the right to make corrections, modifications, enhancements, improvements, and other changes to its products and services.

WE DOES NOT WARRANT OR REPRESENT THAT ANY LICENSE,

EITHER EXPRESS OR IMPLIED, IS GRANTED UNDER ANY PATENT RIGHT, COPYRIGHT, MASK WORK RIGHT, OR OTHER INTELLECTUAL PROPERTY RIGHT RELATING TO ANY COMBINATION, MACHINE, OR PROCESS IN WHICH WE PRODUCTS OR SERVICES ARE USED. INFORMATION PUBLISHED BY WE REGARDING THIRD-PARTY PRODUCTS OR SERVICES DOES NOT CONSTITUTE A LICENSE FROM WE TO USE SUCH PRODUCTS OR SERVICES OR A WARRANTY OR ENDORSEMENT THEREOF.

WE products are not authorized for use in safety-critical applications, or where a failure of the product is reasonably expected to cause severe personal injury or death. Moreover, WE products are neither designed nor intended for use in areas such as military, aerospace, aviation, nuclear control, submarine, transportation (automotive control, train control, ship control), transportation signal, disaster prevention, medical, public information network etc. Customers shall inform WE about the intent of such usage before design-in stage. In certain customer applications requiring a very high level of safety and in which the malfunction or failure of an electronic component could endanger human life or health, customers must ensure that they have all necessary expertise in the safety and regulatory ramifications of their applications. Customers acknowledge and agree that they are solely responsible for all legal, regulatory and safety-related requirements concerning their products and any use of WE products in such safety-critical applications, notwithstanding any applications-related information or support that may be provided by WE.

CUSTOMERS SHALL INDEMNIFY WE AGAINST ANY DAMAGES ARISING OUT OF THE USE OF WE PRODUCTS IN SUCH SAFETY-CRITICAL APPLICATION.

USEFUL LINKS



Application Notes

www.we-online.com/apnotes



REDEXPERT Design Platform

www.we-online.com/redexpert



Toolbox

www.we-online.com/toolbox



Product Catalog

www.we-online.com/products

CONTACT INFORMATION



apnotes@we-online.com

Tel. +49 7942 945 - 0



Würth Elektronik eiSos GmbH & Co. KG

Max-Eyth-Str. 1 74638 Waldenburg Germany

www.we-online.com

APPLICATION NOTE

ANP045 | Behind the Magic of High Frequency

REVISION HISTORY

Document Version	Release Date	Changes
ANP045a	2020/10/21	Initial release of the application note
ANP045b	2026/03/19	Transferred to new graphical template and minor phrasing adjustments

Note: The current version of the document and the release date are indicated in the footer of each page of this document.