

Support Note

Quick Guide for WE-STST designs



SN016 // Jairo Bustos / Robert Schillinger / Simon Mark / Ashiro Chen

1 Introduction

In Ethernet designs for industrial applications, not only isolation transformers are needed but also common mode chokes (CMCs), TVS diodes and capacitors. The key challenge is always to reduce the size of the PCB and therefore the design and the component volume. Würth Elektronik has developed an Ethernet transformer series that has full automated production. The **WE-STST** provides a discrete solution for Ethernet designs, which can save over 50 % of PCB space, whilst still providing the possibility of high transmission rates. Its innovative automated production reduces the electrical deviation and increases the reliability as well as the quality.

This Support Note provides a list of suitable components to use in combination with the WE-STST transformer series and some quick and easy suggestions for good Ethernet PCB design. Figure 1 shows a design example for the Ethernet interface with WE-STST transformers.

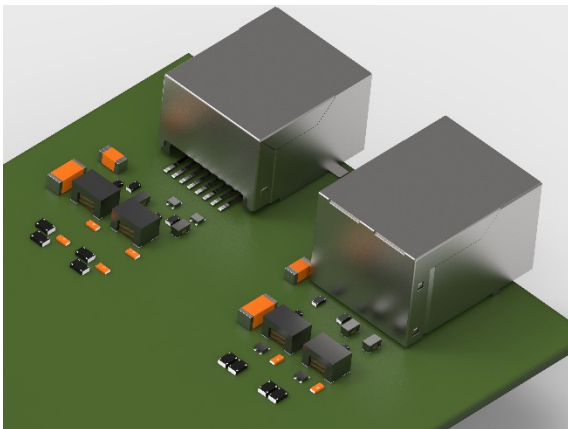

Figure 1: Ethernet PCB with two 100 Base-T connections

2 Super Tiny Signal Transformer WE-STST

The Super Tiny Signal Transformer WE-STST series can save over 50 % of PCB space, as opposed to other individual transformers on the market using ring cores. In order to get a better picture, a WE-STST transformer is over 90 % smaller than a 1 cent coin (figure 2).



Figure 2: Comparison of WE-STST transformer with 1 Euro cent coin (scale 1:4)

3 Application field of the WE-STST series

With its extended temperature range up to +105°C, the WE-STST series finds its main applications in industrial LAN interfaces for factory automation, company networks, IoT devices and many other devices. Furthermore, the WE-STST can be used for a wide range of transmission rates: for multipair Ethernet 10Base-T to 10GBase-T, as well as for Single Pair Ethernet (SPE) from 10Base-T1 to 1000Base-T1 applications. Currently there are two versions of the WE-STST transformer, as listed in table 1.

Article number	Open Circuit Inductance (OCL)
749 300 00	350 μ H
749 301 00	120 μ H

Table 1: WE-STST part numbers

The 749 300 00 has been designed to fulfil the 350 μ H OCL requirements per IEEE 802.3 standards. For 10GBase-T or 1000Base-T1 (SPE) applications, where the signal frequency is higher, parasitic effects should be reduced to a minimum. The 749 301 00 with 120 μ H is designed for these applications.

4 Recommended Components for Designing with WE-STST

4.1. Common mode chokes

The Ethernet communication speed and the frequency range in which the CMC will be designed, are determining factors when it comes to the appropriate selection of it. Depending on the speed of the communication, the common mode (CM) impedance and the insertion losses in differential mode will play a big role. It is important is to reduce the common mode noise while keeping the signal as unaffected as possible. Thus it is important not to go further than the differential resonance frequency attenuating the common mode noise in the affected frequency range.

Taking this into consideration, WE offers the **WE-CNSW** series for Ethernet applications in combination with the WE-STST series. In figure 3, a comparison of three of them is being shown.

Article number	Series	Z @ 100 MHz	Suitable for
744 233 59 00	WE-CNSW HF 0504	90 Ω	10/100/1G/10G Base-T 10/100 Base-T1
744 231 261	WE-CNSW 0805	260 Ω	10/100/1G/10G Base-T 10/100 Base-T1
744 231 371	WE-CNSW 0805	370 Ω	10/100/1G/10G Base-T 10/100 Base-T1

Table 2: Suggested CMC part numbers

Support Note

Quick Guide for WE-STST designs

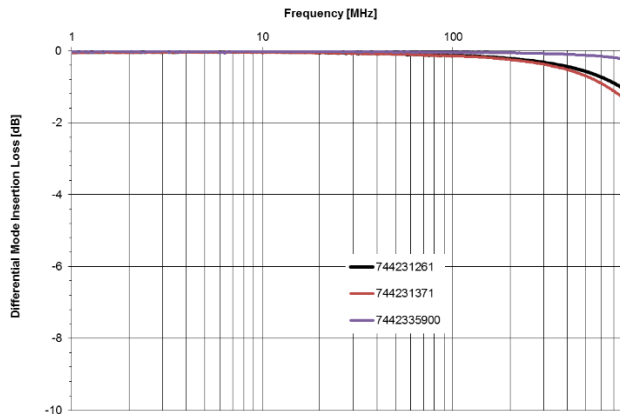

Figure 3: CMC comparison of DM insertion loss (sdd21)

4.2. TVS diodes

TVS diodes are also needed in Ethernet designs for ESD protection. It is recommended to place unidirectional diodes on the PHY side of the transformer and bidirectional diodes on the cable side. This is due to the nature of the differential signals on both sides of the transformer.

Another important aspect to be mentioned concerns the insulation voltage test. In order not to damage components during the test, e.g. the TVS diodes, they can be removed from the circuit before the test, according to section 5.4.9. of IEC 62368 “to avoid damage to components or insulations that are not involved in the test, ICs or the like, may be disconnected and equipotential bonding may be used” ... “components providing a DC path in parallel with the insulation to be tested, ... , may be disconnected”.

The following part numbers from the **WE-TVS** series are recommended for Ethernet designs.

Article number	Series	Channel operating voltage
824 014	WE-TVS Super Speed Series	5 V
824 012 823	WE-TVS Super Speed Series	3.3 V

Table 3: Suggested TVS diodes part numbers

4.3. Capacitors

Capacitors are also needed in Ethernet designs together with the magnetics. On the cable side of the magnetics, the Bob Smith termination is used, which contains a 2 kV capacitor. On the PHY side, the center taps will be connected to either V_{CC} or ground, via capacitors. Connection to AV_{CC} or ground will depend on the PHY chip: whether voltage or current-driven. In this case, they are 50 V capacitors. In

figures 4 and 5, one may see how the center taps are connected, depending on voltage or current-driven PHY chips.

Article number	Series	Voltage
885 342 208 024	WCAP-CSMH 1206	2 kV
885 342 210 004	WCAP-CSMH 1808	3 kV
885 012 205 086	WCAP-CSGP 0402	50 V

Table 4: Suggested capacitor part numbers

5 Ethernet PCB design

Both voltage and current-driven PHY chips can be found on the market. The schematics in Figure 4 and 5 show the magnetics connection for 10/100 Base-T with both voltage and current-driven PHY chips.

The magnetics should be placed as close as possible to the connector, to avoid EMC interference due to coupling of long conductive paths in the device. The length of the traces should be less than 25 mm with an impedance of 50Ω to ground and 100Ω differential impedance. On the other side, the TVS diodes should be placed on the PHY side of the isolation transformer, since placing them on the connector side may lead to insulation voltage test failures.

There are some basic rules when it comes to designing PCBs for differential signaling applications, such as Ethernet:

- Differential signal lines should be as short as possible in order to avoid parasitic effects which may affect the signal integrity. Maximum length shall not be greater than 100 mm
- Differential signal lines should run parallel to each other with a separation of at least 0.5 mm and should run symmetrical. Transmitting and receiving pairs should be placed on different layers, with a ground plane in between, to avoid mutual coupling
- The length of differential signal lines should be the same or as similar as possible in order to avoid timing shifts respect to one another and common mode interference. A maximum of 1.25 mm difference is suggested
- 90° corners shall be avoided. Instead 45° angled corners are better since they shorten the electrical path of the signal
- Width of the traces should be constant to maintain the characteristic impedance of 100Ω
- inductive components generate a magnetic field in their proximity. Therefore, PHY chip manufacturers recommend a minimum distance of 25mm between the inductive components and the chip..
- In case of a discrete magnetics – RJ45 connector combination, the magnetics should be placed less than 25 mm apart from the connector. In case, due to layout restrictions, this distance needs to be bigger, the impedance should be kept always close to 100Ω .

Support Note

Quick Guide for WE-STST designs

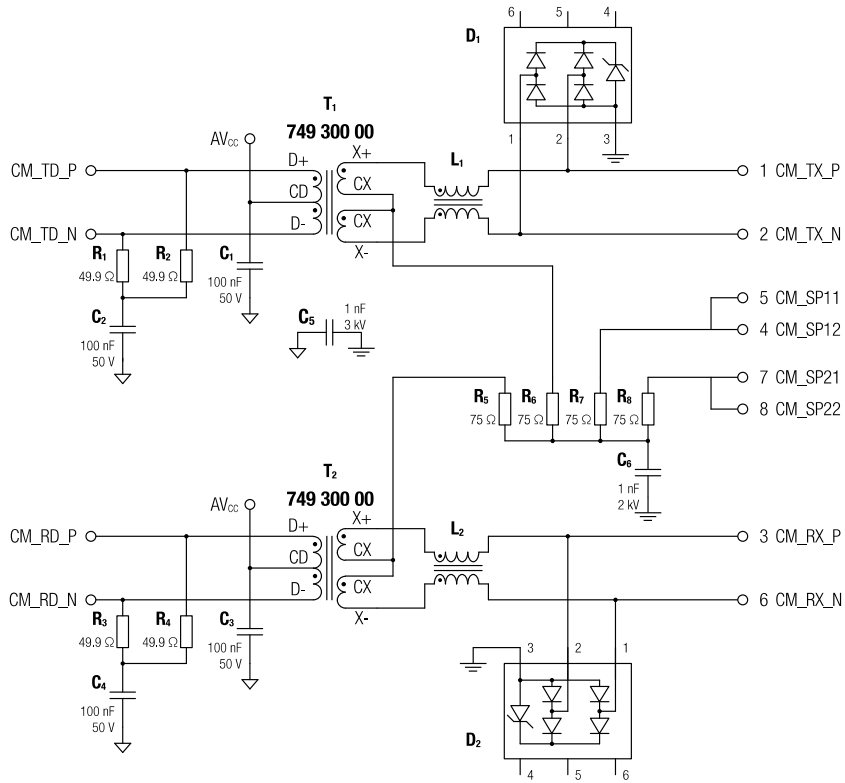

Figure 4: Schematic with current-driven PHY

(*Note: R₁, R₂, R₃ and R₄ can already be included in the PHY or are specified in the PHY datasheet; typically with 49.9 Ω)

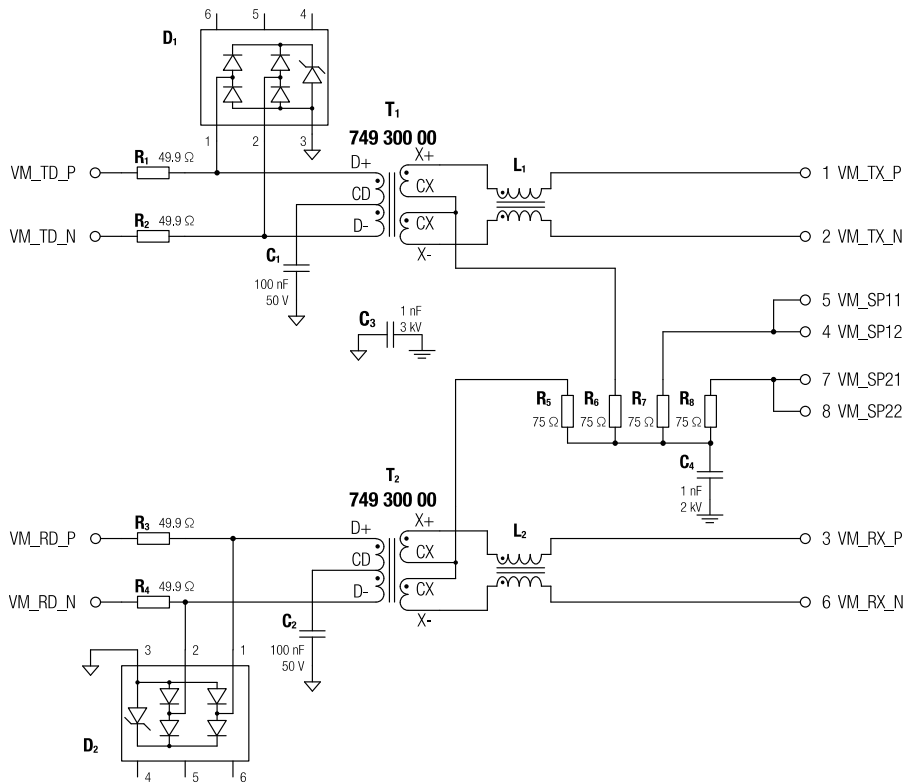

Figure 5: Schematic with voltage-driven PHY

(*Note: R₁, R₂, R₃ and R₄ can already be included in the PHY or are specified in the PHY datasheet; typically with 49.9 Ω)

Support Note

Quick Guide for WE-STST designs



IMPORTANT NOTICE

The Application Note is based on our knowledge and experience of typical requirements concerning these areas. It serves as general guidance and should not be construed as a commitment for the suitability for customer applications by Würth Elektronik eiSos GmbH & Co. KG. The information in the Application Note is subject to change without notice. This document and parts thereof must not be reproduced or copied without written permission, and contents thereof must not be imparted to a third party nor be used for any unauthorized purpose.

Würth Elektronik eiSos GmbH & Co. KG and its subsidiaries and affiliates (WE) are not liable for application assistance of any kind. Customers may use WE's assistance and product recommendations for their applications and design. The responsibility for the applicability and use of WE Products in a particular customer design is always solely within the authority of the customer. Due to this fact it is up to the customer to evaluate and investigate, where appropriate, and decide whether the device with the specific product characteristics described in the product specification is valid and suitable for the respective customer application or not.

The technical specifications are stated in the current data sheet of the products. Therefore the customers shall use the data sheets and are cautioned to verify that data sheets are current. The current data sheets can be downloaded at www.we-online.com. Customers shall strictly observe any product-specific notes, cautions and warnings. WE reserves the right to make corrections, modifications, enhancements, improvements, and other changes to its products and services.

WE DOES NOT WARRANT OR REPRESENT THAT ANY LICENSE, EITHER EXPRESS OR IMPLIED, IS GRANTED UNDER ANY PATENT RIGHT,

COPYRIGHT, MASK WORK RIGHT, OR OTHER INTELLECTUAL PROPERTY RIGHT RELATING TO ANY COMBINATION, MACHINE, OR PROCESS IN WHICH WE PRODUCTS OR SERVICES ARE USED. INFORMATION PUBLISHED BY WE REGARDING THIRD-PARTY PRODUCTS OR SERVICES DOES NOT CONSTITUTE A LICENSE FROM WE TO USE SUCH PRODUCTS OR SERVICES OR A WARRANTY OR ENDORSEMENT THEREOF.

WE products are not authorized for use in safety-critical applications, or where a failure of the product is reasonably expected to cause severe personal injury or death. Moreover, WE products are neither designed nor intended for use in areas such as military, aerospace, aviation, nuclear control, submarine, transportation (automotive control, train control, ship control), transportation signal, disaster prevention, medical, public information network etc. Customers shall inform WE about the intent of such usage before design-in stage. In certain customer applications requiring a very high level of safety and in which the malfunction or failure of an electronic component could endanger human life or health, customers must ensure that they have all necessary expertise in the safety and regulatory ramifications of their applications. Customers acknowledge and agree that they are solely responsible for all legal, regulatory and safety-related requirements concerning their products and any use of WE products in such safety-critical applications, notwithstanding any applications-related information or support that may be provided by WE.

CUSTOMERS SHALL INDEMNIFY WE AGAINST ANY DAMAGES ARISING OUT OF THE USE OF WE PRODUCTS IN SUCH SAFETY-CRITICAL APPLICATIONS.

USEFUL LINKS



Application Notes

www.we-online.com/app-notes



REDEXPERT Design Tool

www.we-online.com/redexpert



Toolbox

www.we-online.com/toolbox



Product Catalog

www.we-online.com/products

CONTACT INFORMATION

appnotes@we-online.com

Tel. +49 7942 945 - 0



Würth Elektronik eiSos GmbH & Co. KG
Max-Eyth-Str. 1 · 74638 Waldenburg · Germany

www.we-online.com

