

APPLICATION NOTE



Going Wireless with Magnetic Shielding

ANP016 BY JORGE VICTORIA AHUIR

1. Why we need Magnetic Shielding

Magnetic Field Interferences are increasing in electronic devices due to a number of factors including reduced separation distances of PCB's, Integrated Circuits and many other sensitive components. In addition to this the extended use of magnetically coupled communication technologies (Qi-WPC, NFC, RFID, PMA, A4WP, WCT...) leads to more complex layout and proximity considerations.

With Ferrite materials it is possible to manage and predict magnetic flux flow and thereby improve efficiency of power transfers, increase distances of near field communications and of course avoid additional unwanted coupling effects which could lead to losses or noise.

2. Shielding with Ferrites

Magnetic materials have a property which allows them to influence the magnetic field in its environment. Materials such as ferrite have a greater permeability to magnetic fields (H) than the air around them and therefore concentrate the magnetic field lines as can be seen in Fig 1. By strategic placement of ferrite materials we are able to concentrate this magnetic field and therefore influencing the intensity and shape of a field. We can utilise this effect to improve efficiency and reduce coupling effects. The parameter which we use to quantify material characteristics with in a magnetic field is called the relative permeability which can be defined as:

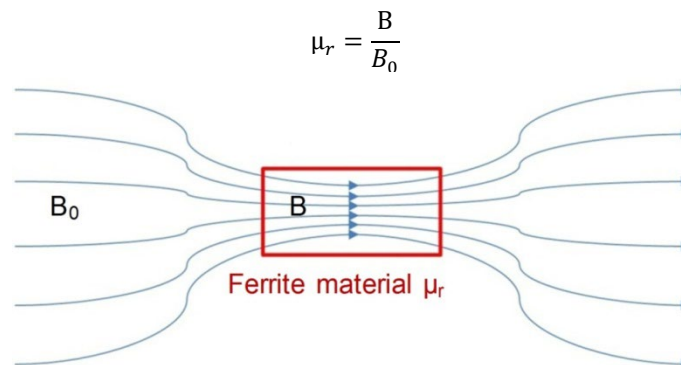

Figure 1 Ferrite material effect

We also have losses within the magnetic material which can be caused by hysteresis and eddy currents internal to the material. These losses will transfer from magnetic field energy to heat, generating a self-heating of the product. In order to quantify the losses of these magnetic flux redirections we must separate the permeability into its complex form, the ideal part μ' and the losses or reactive part μ'' . As you can see below we can express these 2 areas as a complete complex permeability.

$$\mu_r = \mu' - j\mu''$$

APPLICATION NOTE



Going Wireless with Magnetic Shielding

Ferrite materials with high μ'' are useful and utilised when dealing with noise, such as in noise filters or our WE-CBF range. Whereas high μ' materials are utilised in order to maximise magnetic flux control with minimum losses. Both of these parameters are of course dependant on frequency (fig 4). The correct selection of material is then paramount to the suitability of the material in the specific frequency of the application and maximise the desired effect of filtering or control.

The on-going challenge of increased efficiency, greater shielding and increased transmission distances is highlighted no more so than in the utilisation of near field and wireless communications. The integration of these magnetically coupled technologies into highly populated integrated electronic circuitry, where both space and weight are limited, can lead to a number of undesired effects. This can then lead to reduced effectiveness and greater losses.

Classic Conductive shields protect against undesired noise couplings by generating an opposite field, reflecting the noise or even conducting the induced energy to a ground plane. This effect however will be as effective on the intended transmission, filtering the very signal it wishes to protect.

The best option is to concentrate and maximise the magnetic field only where it is needed, protecting the surroundings and increasing the efficiency. The materials with a high μ' and low μ'' at the communication frequency are needed to achieve this. In the Würth Elektronik portfolio we offer a number of ranges which can match these requirements

Dielectro-magnetic Sheet WE-FAS (Figure 2): This composite material is formed by a polymer filled with ferrite powder. It offers big flexibility but their magnetic properties are reduced because of the polymer. Their μ'' extends up to several gigahertz and they are also able to attenuate the electrical field, so they are a good option for high frequency EMI reduction.



Figure 2 WE-FAS Flexible Absorber Sheet

Flexible Sintered Ferrite Sheet WE-FSFS (Figure 3): This new line of materials provides high permeability and low losses with very low thickness (from 0.1 mm). They are composed by pre-cracked thin ferrite plates placed between a layer of adhesive tape and a PET cover layer that provides protection, high surface resistivity and top to bottom isolation. They are the best option for constructive magnetic flux management



Figure 3 WE-FSFS Flexible Sintered Ferrite Sheet

APPLICATION NOTE



Going Wireless with Magnetic Shielding

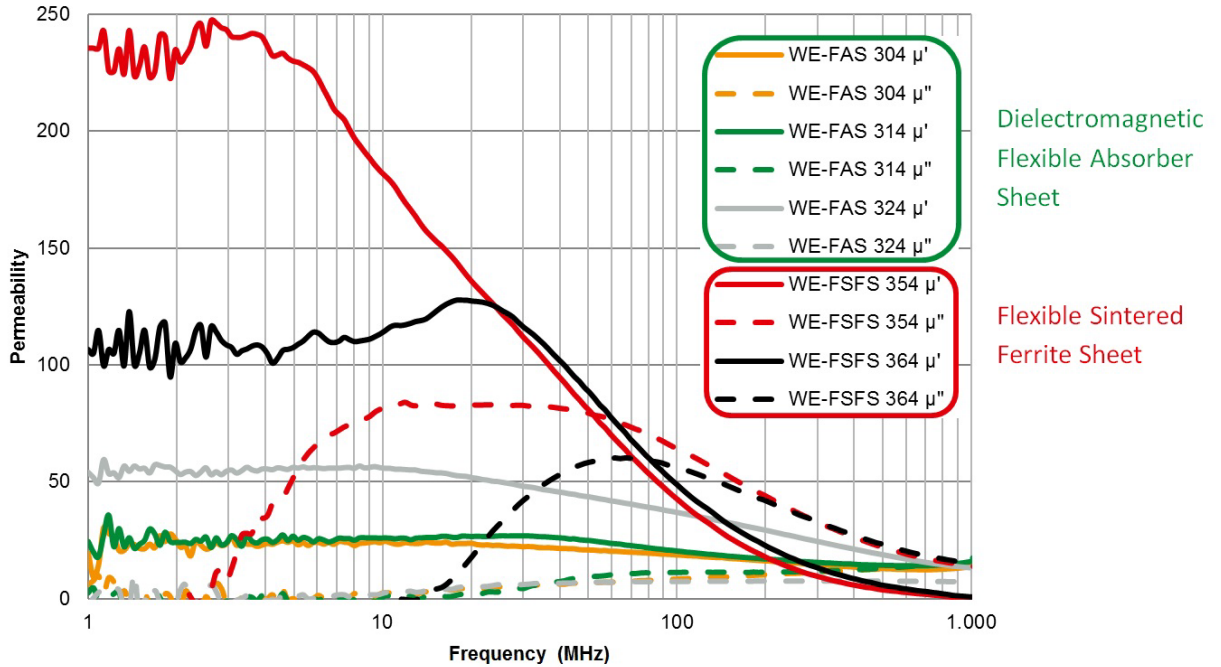

Figure 4 Complex permeability of ferrite materials

3. Wireless Power

During energy transfer in a magnetically coupled pair of coils the magnetic flux flows from the transmitter through the receiver, using its surrounding environment to provide the return path. As you can see in Figure 5 this directed flux can flow up through the receiver and continue into the device being charged. This will have negative effects, as these magnetic fields will cause self heating within any conductive component other than the charge coil (eg Battery). The inductive coupling will also provide noise current loops in these conductive materials (Eg IC's, PCB traces, etc) thus creating EMI Issues.

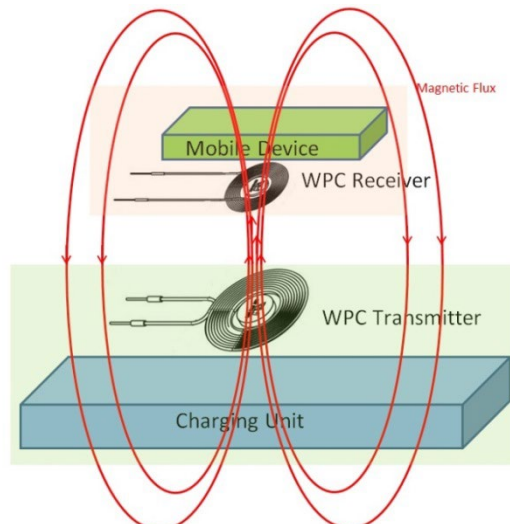

Figure 5: Wireless power magnetic flux without shielding

APPLICATION NOTE



Going Wireless with Magnetic Shielding

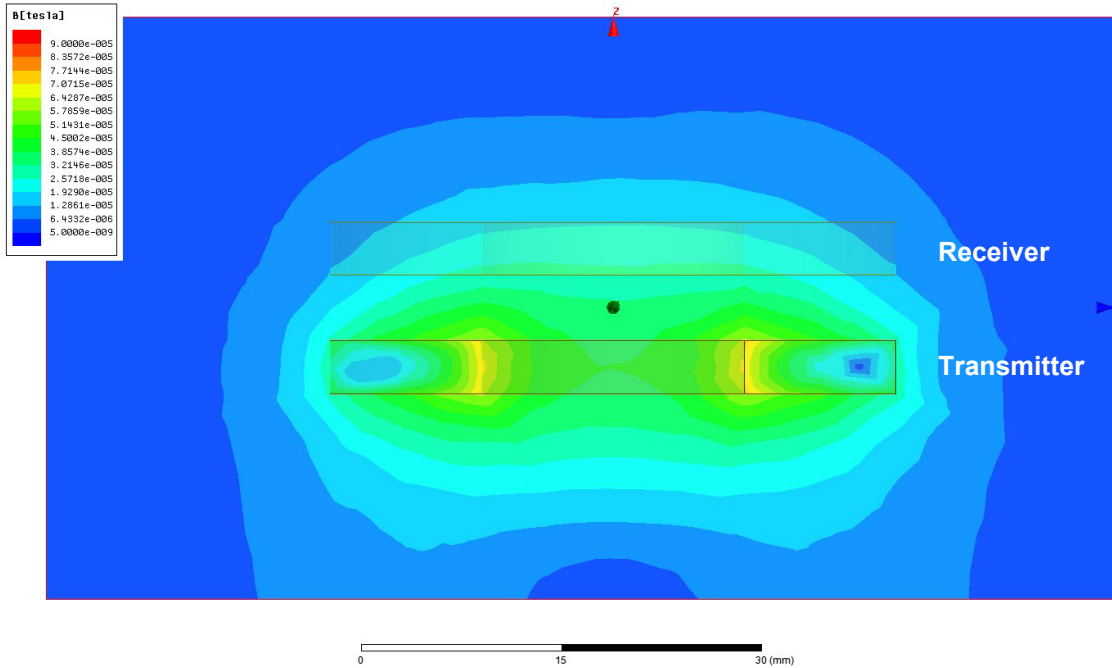

Figure 6: Magnetic flux density distribution without shielding (software simulation)

In Figure 6 the image shows the result of a simulation. This shows with colors how the flux is concentrated in the transmitter coil (green and yellow) and the interaction with the receiver coil but also shows us the field which passes beyond this into the back of the transmitter particularly (light blue).

Placing ferrite sheets behind the transmitter and receiver coils, the flux is concentrated in the area between them, and the circuitry outside is protected. (Figure 7, Figure 8)

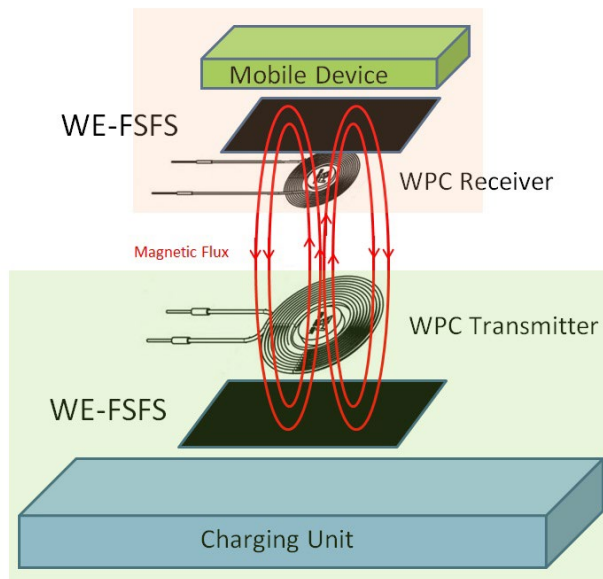

Figure 7: Wireless power with shielding

APPLICATION NOTE



Going Wireless with Magnetic Shielding

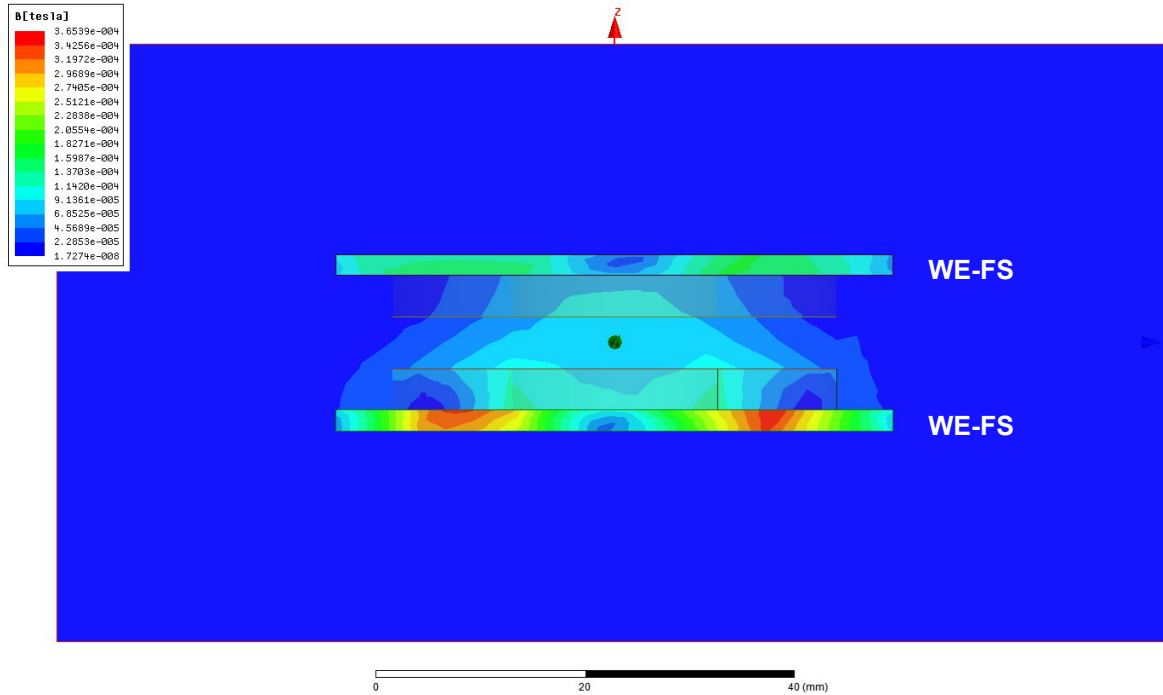

Figure 8: Magnetic flux density with shielding (software simulation)

There are several wireless power standards working with inductive charging incorporating different frequencies (Table 1). The ferrite sheet material must be selected accordingly to give maximum performance (maximum μ' and minimum μ''). WE-FSFS 354 losses μ'' are lower than 2 up to 2 MHz while its μ' is higher than 200, and it is the perfect shield for Qi and PMA standards. For higher frequencies the best option is WE-FSFS 364 because of its low losses ($\mu'' < 2$) up to 13,56 MHz while its μ' is still above 100.

Wireless Standards	Power Transfer	Frequency Range
WPC-Qi		100 – 205 KHz
PMA		277 – 357 KHz
A4WP		6.78 MHz
WCT		13.56 MHz

Table 1: Wireless Power working frequencies

4. Near Field Communication (NFC)

NFC applications like mobile payment, public transport or access control, use 13.56 MHz to communicate data. Emitter and receiver coils must be accurately tuned to resonate at this frequency and usually a matching circuit is included in their circuitry.

But the presence of a conductive surface (i.e. battery, ground plane, metallic enclosure) close to one of the coils will not allow the communication due to the shielding effects of these devices. The flux generated by the Reader (blue lines) traverse the conductive plane generating eddy currents.

APPLICATION NOTE



Going Wireless with Magnetic Shielding

These eddy currents generate an opposite flux (red lines) reducing the efficiency of the communication (Figure 9: NFC-RFID communication without shielding, Figure 10: Conductive plane effect in magnetic flux distribution (simulation)). At the same time, the presence of the conductive material close to either transmit or receive coils, reduces their inductance. The resonance frequency will consequently increase and thus takes the circuit out of tune with the resonance frequency. This will increase the fail rate and could prevent successful communication.

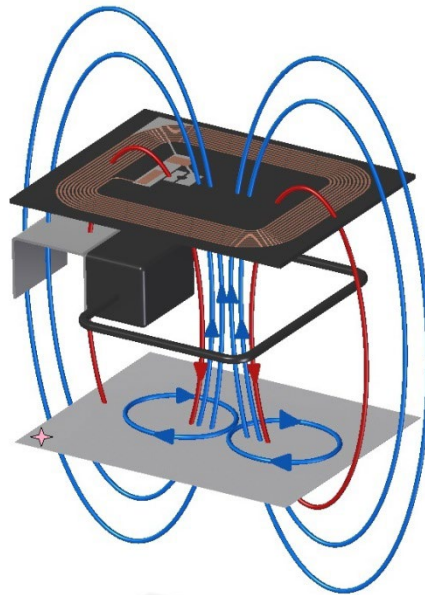

Figure 9: NFC-RFID communication without shielding

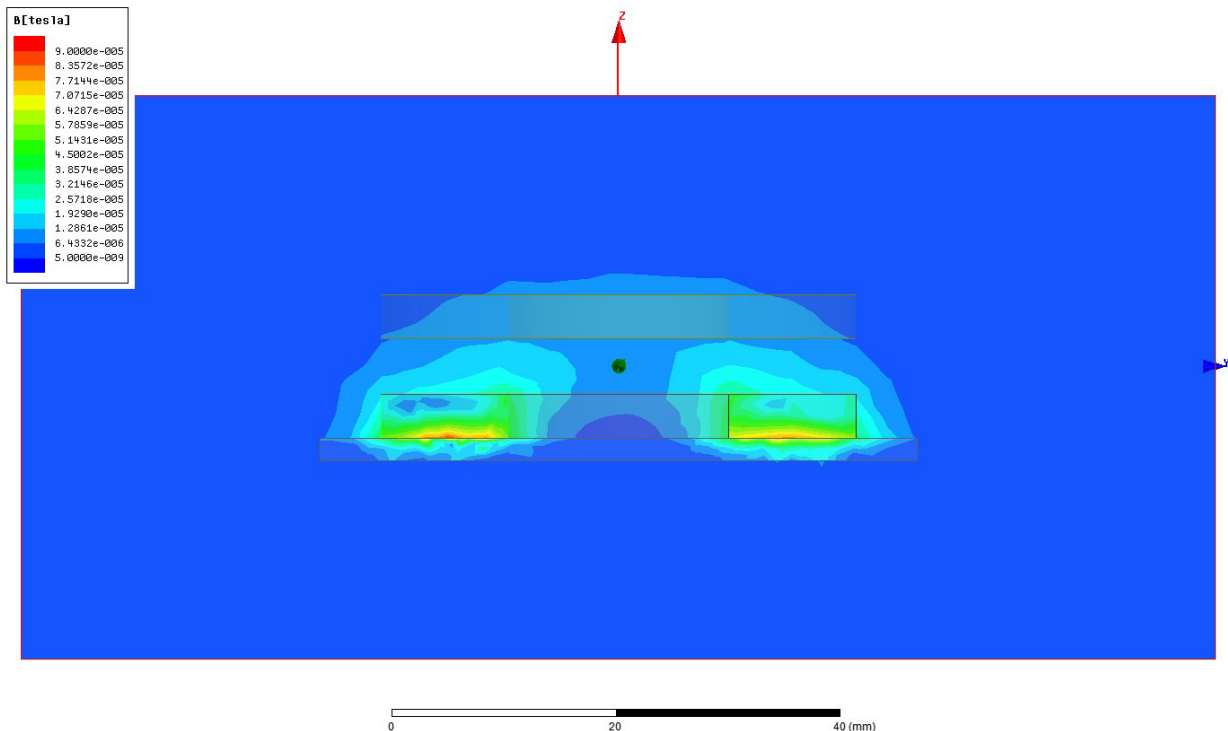

Figure 10: Conductive plane effect in magnetic flux distribution (simulation)

APPLICATION NOTE



Going Wireless with Magnetic Shielding

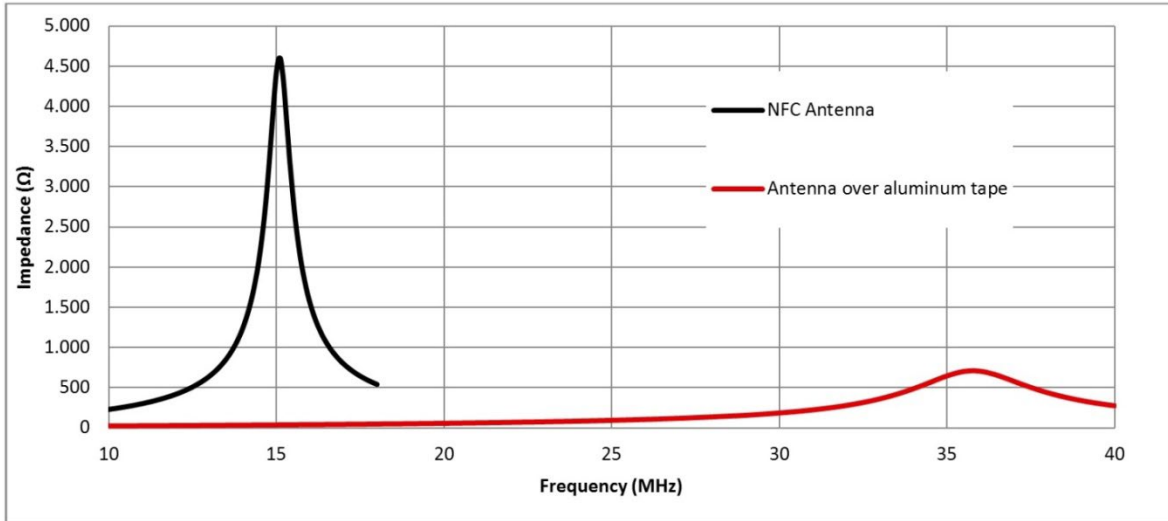

Figure 11: Conductive plane effect (frequency shift and Q reduction)

The loss in inductance value comes about by increasing the losses of the coils due to the losses created in the conductive material by the eddy currents. This will add to the R_{DC} of the coil, and the Q factor of the resonance will drop (Figure 11: Conductive plane effect (frequency shift and Q reduction)).

$$Q = \frac{\omega_0 L}{R}$$

It will be very difficult for the matching circuit to compensate these shifts in frequency and Q.

A ferrite sheet WE-FSFS 364 with high μ' at 13.56 MHz can redirect the flux, avoiding the conductive plane, the eddy currents, and increase the inductance.

Low losses (μ'') at the same frequency will assure that the losses (R) are not increased significantly, thus ensuring a high quality (Q) resonance (Figure 12, Figure 13, Figure 14)

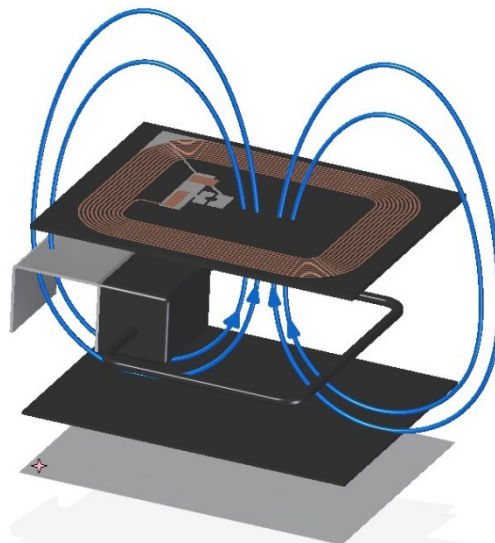

Figure 12: NFC-RFID shielding

APPLICATION NOTE



Going Wireless with Magnetic Shielding

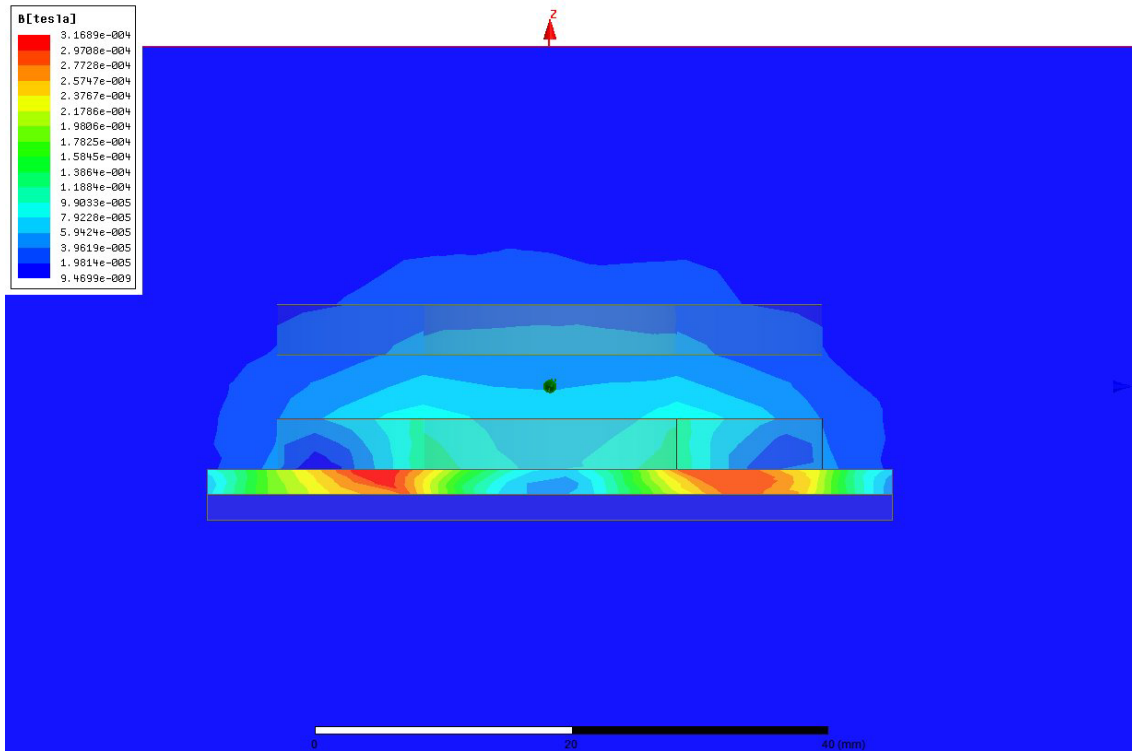

Figure 13: Conductive plan with ferrite shielding (simulation)

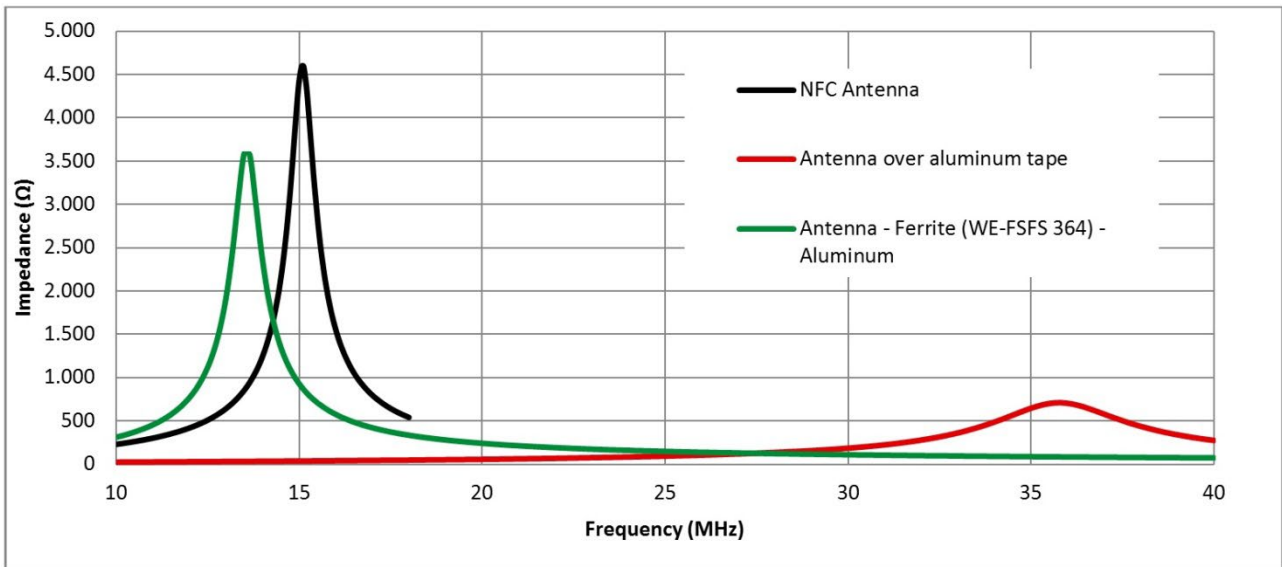

Figure 14: Ferrite shield countermeasure (frequency shift back and Q increases)

APPLICATION NOTE



Going Wireless with Magnetic Shielding

5. Summary

After an explanation of the mechanism and the measurements associated with inductively coupled products we can demonstrate that improvements can be made due to the behavior of our ferrite materials (especially ferrite sheets). Thanks to their ability to control the magnetic flux, they can provide excellent shielding performance in critical applications such as power transfer and near field communication.

Choosing the correct materials according to the frequency, understanding the need for maximum μ' and minimum μ'' coupled with correct placement in the application will lead to a high level of transfer efficiency. At the same time undesired interferences, emissions and heating of the device will be minimized with reduced stray fields.

Thanks to their high performance and their low thickness Würth Elektronik eiSos WE-FSFS flexible sintered ferrite sheets are an indispensable partner for these technologies, which are on their way to achieve higher efficiency and higher integration level into all electronics.

Group	Order Code	Version	L (mm)	W (mm)	H (mm)	R _{Surface} (GΩ)	μ' @ 1 (MHz)	μ' @ 13.56 (MHz)	μ'' @ 1 (MHz)	μ'' @ 13.56 (MHz)
WE-FSFS 354 (WPC-Qi, PMA)	354 001	square	120	120	0.1	> 1	230	150	< 2	90
	354 002	square	120	120	0.2	> 1	230	150	< 2	90
	354 003	square	120	120	0.3	> 1	230	150	< 2	90
	354 004	square	60	60	0.1	> 1	230	150	< 2	90
	354 005	square	60	60	0.2	> 1	230	150	< 2	90
	354 006	square	60	60	0.3	> 1	230	150	< 2	90
WE-FSFS 364 (A4WP, WCT)	364 001	square	120	120	0.1	> 1	110	120	< 2	2
	364 002	square	120	120	0.2	> 1	110	120	< 2	2
	364 003	square	120	120	0.3	> 1	110	120	< 2	2
	364 004	square	60	60	0.1	> 1	110	120	< 2	2
	364 005	square	60	60	0.2	> 1	110	120	< 2	2
	364 006	square	60	60	0.3	> 1	110	120	< 2	2

APPLICATION NOTE



Going Wireless with Magnetic Shielding

IMPORTANT NOTICE

The Application Note is based on our knowledge and experience of typical requirements concerning these areas. It serves as general guidance and should not be construed as a commitment for the suitability for customer applications by Würth Elektronik eiSos GmbH & Co. KG. The information in the Application Note is subject to change without notice. This document and parts thereof must not be reproduced or copied without written permission, and contents thereof must not be imparted to a third party nor be used for any unauthorized purpose.

Würth Elektronik eiSos GmbH & Co. KG and its subsidiaries and affiliates (WE) are not liable for application assistance of any kind. Customers may use WE's assistance and product recommendations for their applications and design. The responsibility for the applicability and use of WE Products in a particular customer design is always solely within the authority of the customer. Due to this fact it is up to the customer to evaluate and investigate, where appropriate, and decide whether the device with the specific product characteristics described in the product specification is valid and suitable for the respective customer application or not.

The technical specifications are stated in the current data sheet of the products. Therefore the customers shall use the data sheets and are cautioned to verify that data sheets are current. The current data sheets can be downloaded at www.we-online.com. Customers shall strictly observe any product-specific notes, cautions and warnings. WE reserves the right to make corrections, modifications, enhancements, improvements, and other changes to its products and services.

WE DOES NOT WARRANT OR REPRESENT THAT ANY LICENSE, EITHER EXPRESS OR IMPLIED, IS GRANTED UNDER ANY PATENT RIGHT, COPYRIGHT, MASK WORK RIGHT, OR OTHER INTELLECTUAL PROPERTY RIGHT RELATING TO ANY COMBINATION, MACHINE, OR PROCESS IN WHICH WE PRODUCTS OR SERVICES ARE USED. INFORMATION PUBLISHED BY WE REGARDING THIRD-PARTY PRODUCTS OR SERVICES DOES NOT CONSTITUTE A LICENSE FROM WE TO USE SUCH PRODUCTS OR SERVICES OR A WARRANTY OR ENDORSEMENT THEREOF.

WE products are not authorized for use in safety-critical applications, or where a failure of the product is reasonably expected to cause severe personal injury or death. Moreover, WE products are neither designed nor intended for use in areas such as military, aerospace, aviation, nuclear control, submarine, transportation (automotive control, train control, ship control), transportation signal, disaster prevention, medical, public information network etc. Customers shall inform WE about the intent of such usage before design-in stage. In certain customer applications requiring a very high level of safety and in which the malfunction or failure of an electronic component could endanger human life or health, customers must ensure that they have all necessary expertise in the safety and regulatory ramifications of their applications. Customers acknowledge and agree that they are solely responsible for all legal, regulatory and safety-related requirements concerning their products and any use of WE products in such safety-critical applications, notwithstanding any applications-related information or support that may be provided by WE. CUSTOMERS SHALL INDEMNIFY WE AGAINST ANY DAMAGES ARISING OUT OF THE USE OF WE PRODUCTS IN SUCH SAFETY-CRITICAL APPLICATIONS.

USEFUL LINKS

Application Notes:

<http://www.we-online.com/app-notes>

Component Selector:

<http://www.we-online.com/component-selector>

Toolbox:

<http://www.we-online.com/toolbox>

Product Catalog:

<http://katalog.we-online.de/en/>

CONTACT INFORMATION

Würth Elektronik eiSos GmbH & Co. KG

Max-Eyth-Str. 1, 74638 Waldenburg, Germany

Tel.: +49 (0) 7942 / 945 – 0

Email: appnotes@we-online.de

Web: <http://www.we-online.com>