

APPLICATION NOTE



EMC Filter for DC/DC switching controller optimized

ANP005c BY STEFAN KLEIN

1. Efficiency versus EMC

Modern power supplies need to reduce power loss to maintain a high degree of efficiency. Switch mode power supplies and DC/DC switching controllers are state of the art and allow great efficiency, but if the design of the circuit and circuit board layout is less than ideal this can result in increased emission of radio interference voltage. This article discusses the systematic implementation of input filters for reducing symmetric interfering voltage in DC/DC switching controllers.

2. Demand for an input filter

Whether you have a switch mode power supply or DC/DC switching controller, every type of switch mode power supply creates a broadband interference emission in the form of interfering voltage and interference fields that can make other electrical devices malfunction. The main cause for the interfering voltage is current at the input that flows through the input capacitor of the switching controller with the clock frequency of the switching controller. It causes a voltage drop V_{Ripple} via the ESR that consists of a proportional percentage by the ESR and an integrated percentage by the capacity.

3. Measurement of the interfering voltage

This can be corrected by an input filter that reduces the amplitude of the interfering voltage, suppresses harmonics and plays a vital role in reducing the radio interference voltage to an acceptable level. For example, the generic standard EN61000-6-4 establishes at 150 kHz a limit value of the virtual peak value of 79 dB μ V. The current market for passive components offers a broad portfolio of "ready-made filters" that are marketed with high insertion loss. Insertion losses between 70 dB and 100 dB are declared, for example. But these values are rarely achieved in practice because such filters were measured in a 50 Ω system and the impedances of the power supplies deviate from these values. The development of an individual filter is recommended. To begin with, the interference type should be identified for developing an input filter. A distinction must be made between differential mode and common mode noise. A filter is employed at the input of the switching controller to suppress the differential mode noise. Even during development, the measurement of the interfering voltage can be carried out with an LISN (Line Impedance Stabilization Network) and a spectrum analyzer. Fig. 1 shows the test setup of such a measurement process. Based on such a setup, the pure differential mode noises can be measured because the reference potential is the switching ground and not the reference ground.

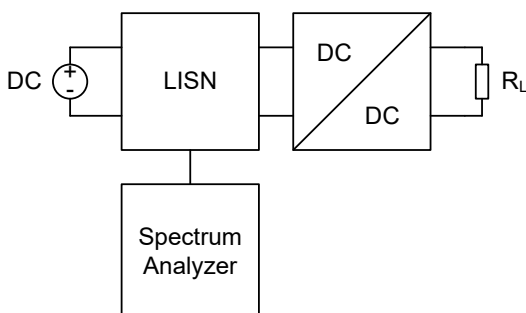

Image 1: Test set up

APPLICATION NOTE



EMC Filter for DC/DC switching controller optimized

The LISN has the task of uncoupling the interfering voltage as an alternating quantity. The internal low-pass filter of the LISN prevents other electrical devices that are attached to the public power supply from malfunctioning. Fig. 2 shows the interfering voltage V_{noise} in dB μ V of a DC/DC step-down controller measured this way that has a switching frequency of 2 MHz, an input voltage of 10 V, and an effective input current of 0.7 A.

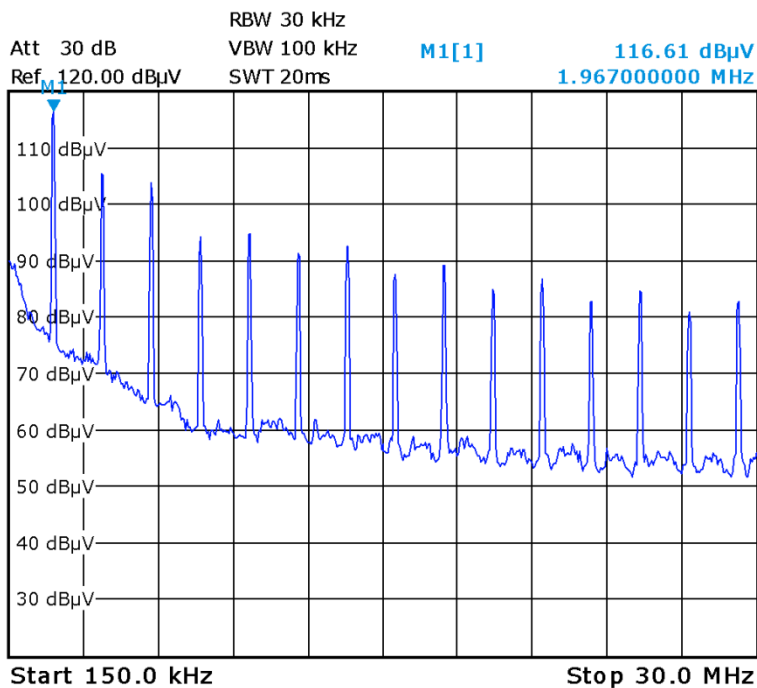

Image 2: Interfering voltage without input filter

The interfering voltage level V_{noise} is defined by the following formula in dB:

$$V_{\text{noise}} = 20 \log \left(\frac{V_{\text{Ripple}}}{1 \mu\text{V}} \right) \text{dB}\mu\text{V}$$

Clearly visible is the fundamental, corresponding to the switching frequency. The harmonics, which go as high as the upper MHz area, drop in amplitude, but are still above the limit value. At 116 dB μ V the fundamental has its greatest amplitude. Based on this, the V_{Ripple} can be determined by:

$$V_{\text{Ripple}} = \left(10^{\frac{V_{\text{noise}}}{20}} \right) \cdot 1 \mu\text{V}$$

The V_{Ripple} is thus 631 mV, which means an input filter is obviously necessary.

APPLICATION NOTE



EMC Filter for DC/DC switching controller optimized

4. Influence of the switcher's control loop

In the following we will examine an input filter that has been fitted to the above-mentioned switching controller. A low-pass filter is built from a coil (WE-PD2, unshielded, $L = 1 \mu\text{H}$, $\text{SRF} = 110 \text{ MHz}$, $R_{\text{DC}} = 49 \text{ m}\Omega$) and a capacitor (FK series, electrolyte, $C = 10 \mu\text{F}$, $U = 35 \text{ V DC}$). The filter is placed in front of the input capacitor of the DC/DC switching controller. Fig. 3 shows the arrangement of the filter.

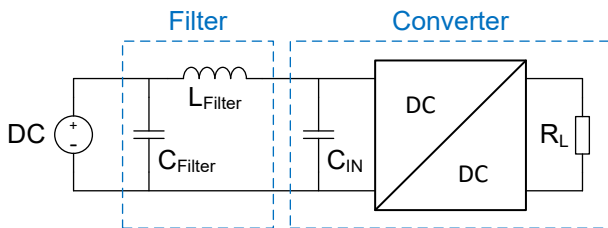

Image 3: Arrangement of the input filter

To begin with, a filter coil with a high self-resonant frequency (SRF) should be selected, because the coil generally loses its filtering capacity in the upper frequency range due to the parasitic capacity. To avoid saturating the core of the filter coil, the permissible saturation current of the filter coil should be at least 10 percent above the peak value of the input current. Here an RDC is advisable that is as low as possible to minimize the DC voltage drop. Now an inductance value is selected so that the corner frequency of the filter is one tenth of the switching controller frequency, thus far below the cross over frequency of the switching controller, and attenuates most of the fundamental and harmonics. With its corner frequency, the input filter features resonance overshoot and is of the highest quality, which is why it is necessary to attenuate the filter. A safe distance is important to have between the filter corner frequency and the cross over frequency of the switching controller to ensure the stability of the switching controller loop. If these frequencies were to overlap, oscillation comes up at the switching controller input and the controller could no longer respond quickly enough to a change in the input voltage. This is caused by the negative input resistance of the switching controller. In theory, $P_{\text{out}} = P_{\text{in}}$ applies to the switching controller. This means that if the starting conditions of the switching controller are constant, the input current I_{in} will decrease as the input voltage U_{in} increases. This effect is due to the negative input resistance of the switching controller Z_{in} which is approximated by the formula:

$$Z_{\text{in}}(\text{DC}) = -\frac{V_{\text{in}}^2}{V_{\text{in}} \cdot I_{\text{in}}}$$

This is a large-signal analysis, however. Due to the components in the switching controller that depend on frequency, the input resistance is dynamic and thus requires a small-signal analysis. As a practical tip it is recommended that the impedance of the input filter Z_{filter} be kept much lower than the input impedance of the switching controller Z_{in} . Therefore the following applies:

$$Z_{\text{filter}} \ll Z_{\text{ein}}$$

Generally, the filter coil does not cause the electromagnetic fields to radiate and an unshielded one such as the WE-PD2 can be selected.

APPLICATION NOTE



EMC Filter for DC/DC switching controller optimized

In choosing the filter capacity, it should be ensured that the maximum permissible operating voltage of the filter capacitor is approx. 25 percent above the supply voltage because every capacitor has a voltage derating. As the voltage increases, the capacity value and thus the filter effectiveness decreases, depending on the dielectric. To ensure a high self-resonant frequency, a low ESL value is advantageous. As an exception, a relative high ESR may be used here, because the ESR deliberately reduces the quality Q of the filter and attenuates the resonance overshoot of the low-pass filter. The selection of a relatively large filter capacity and small filter coil is recommended because the increase in inductivity lowers the self-resonant frequency. Selection of an electrolyte capacitor as filter capacitor is best. To avoid mismatching the impedances, it is important to choose the right arrangement of the filter elements. Due to the input capacitor, the input impedance of the switching controller is less than that of the power supply, so the filter coil should be located between the power supply and the input capacitor of the switching controller. The filter capacitor will subsequently be connected after the coil and parallel to the power supply. The filter coil counteracts the ripple current and the filter capacitor bypasses the interfering voltage after the ground. Fig. 4 shows the new result of the interfering voltage measurement with the additional input filter.

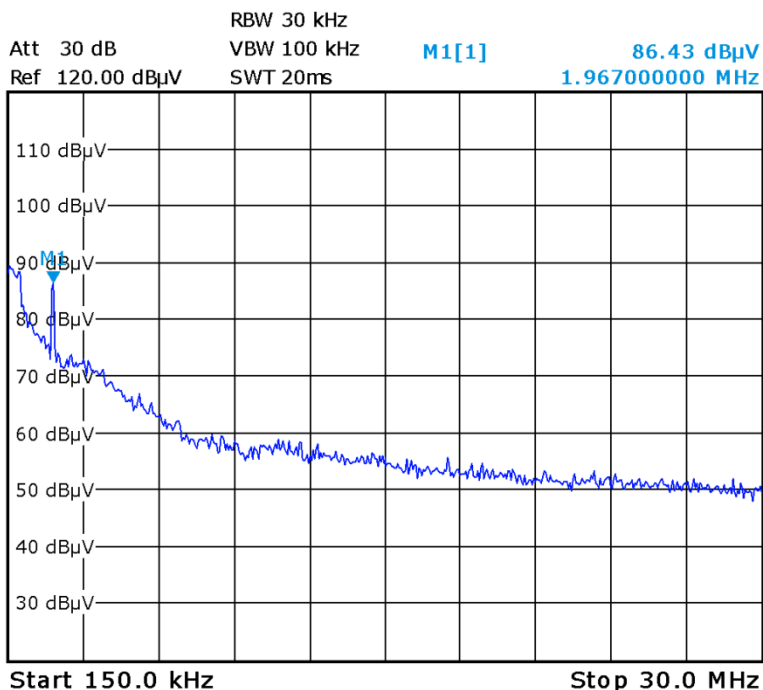

Image 4: Result of the input filter

The filter coil WE-PD2, as well as the filter capacitor, were able to attain an excellent result even with these low inductivity values of 1 μ H and a capacity of 10 μ F. The amplitude of the fundamental was attenuated by 30 dB. The amplitudes of the higher harmonics disappear in the ambient noise. The inductivity value of the filter coil WE-PD2 can be increased further for greater attenuation of the fundamental and entire lower frequency range. Further adjustment of the filter makes an insertion loss of more than 40 dB possible.

APPLICATION NOTE



EMC Filter for DC/DC switching controller optimized

5. Summary of the design tips

An input filter is indispensable and should be considered even during the developmental phase. The differential mode interference can be suppressed at a DC/DC switching controller with an LC filter, and the interfering voltage can be reduced to an acceptable level. If the input filter is well designed and the passive filter elements are sensibly chosen, the highest possible insertion loss can be attained while maintaining the stability of the switching controller.

APPLICATION NOTE



EMC Filter for DC/DC switching controller optimized

IMPORTANT NOTICE

The Application Note is based on our knowledge and experience of typical requirements concerning these areas. It serves as general guidance and should not be construed as a commitment for the suitability for customer applications by Würth Elektronik eiSos GmbH & Co. KG. The information in the Application Note is subject to change without notice. This document and parts thereof must not be reproduced or copied without written permission, and contents thereof must not be imparted to a third party nor be used for any unauthorized purpose.

Würth Elektronik eiSos GmbH & Co. KG and its subsidiaries and affiliates (WE) are not liable for application assistance of any kind. Customers may use WE's assistance and product recommendations for their applications and design. The responsibility for the applicability and use of WE Products in a particular customer design is always solely within the authority of the customer. Due to this fact it is up to the customer to evaluate and investigate, where appropriate, and decide whether the device with the specific product characteristics described in the product specification is valid and suitable for the respective customer application or not.

The technical specifications are stated in the current data sheet of the products. Therefore the customers shall use the data sheets and are cautioned to verify that data sheets are current. The current data sheets can be downloaded at www.we-online.com. Customers shall strictly observe any product-specific notes, cautions and warnings. WE reserves the right to make corrections, modifications, enhancements, improvements, and other changes to its products and services.

WE DOES NOT WARRANT OR REPRESENT THAT ANY LICENSE, EITHER EXPRESS OR IMPLIED, IS GRANTED UNDER ANY PATENT RIGHT, COPYRIGHT, MASK WORK RIGHT, OR OTHER INTELLECTUAL PROPERTY RIGHT RELATING TO ANY COMBINATION, MACHINE, OR PROCESS IN WHICH WE PRODUCTS OR SERVICES ARE USED. INFORMATION PUBLISHED BY WE REGARDING THIRD-PARTY PRODUCTS OR SERVICES DOES NOT CONSTITUTE A LICENSE FROM WE TO USE SUCH PRODUCTS OR SERVICES OR A WARRANTY OR ENDORSEMENT THEREOF.

WE products are not authorized for use in safety-critical applications, or where a failure of the product is reasonably expected to cause severe personal injury or death. Moreover, WE products are neither designed nor intended for use in areas such as military, aerospace, aviation, nuclear control, submarine, transportation (automotive control, train control, ship control), transportation signal, disaster prevention, medical, public information network etc. Customers shall inform WE about the intent of such usage before design-in stage. In certain customer applications requiring a very high level of safety and in which the malfunction or failure of an electronic component could endanger human life or health, customers must ensure that they have all necessary expertise in the safety and regulatory ramifications of their applications. Customers acknowledge and agree that they are solely responsible for all legal, regulatory and safety-related requirements concerning their products and any use of WE products in such safety-critical applications, notwithstanding any applications-related information or support that may be provided by WE. CUSTOMERS SHALL INDEMNIFY WE AGAINST ANY DAMAGES ARISING OUT OF THE USE OF WE PRODUCTS IN SUCH SAFETY-CRITICAL APPLICATIONS.

USEFUL LINKS

Application Notes:

<http://www.we-online.com/app-notes>

REDEXPERT Design Tool:

<http://www.we-online.com/redexpert>

Toolbox:

<http://www.we-online.com/toolbox>

Product Catalog:

<http://katalog.we-online.de/en/>

CONTACT INFORMATION

Würth Elektronik eiSos GmbH & Co. KG

Max-Eyth-Str. 1, 74638 Waldenburg, Germany

Tel.: +49 (0) 7942 / 945 – 0

Email: appnotes@we-online.de

Web: <http://www.we-online.com>