

APPLICATION NOTE



Measurement of the interference voltage on DC/DC switching regulators

1. Challenge

Developers of switched-mode power supplies face the challenge of developing their circuit to be EMC-compliant. Conducted interference particularly occurs in the input circuit whereby other electrical equipment can be disrupted. Therefore the conducted interferences are first checked at the beginning of an EMC test of power supplies. The developer can already perform measurements accompanying the development during the development phase to obtain an impression of possible interference. This Application Note describes the procedure for examining differential mode interference in the input circuit of DC/DC switching regulators.

2. Cause and development of the interference voltage

A distinction is made between differential and common mode interference for conducted interference. The triangular input current of the switching regulator is the active current and initially pure differential mode interference. However, this differential mode interference can transform into common mode interference in the case of unsymmetrical supply lines and results in increased electromagnetic radiation over the supply lines. The differential mode interference can be connected to ground using parasitic capacities and results in common mode interferences. Figure 1 shows the typical input current of a DC/DC switching regulator with a pulse frequency of 2 MHz. The input current flows with the pulse frequency of the switching regulator and resembles the coil current in the illustration flowing through the storage inductance of the switching regulator. The AC component (approx. 260 mA in this example) of the input current is decisive for the differential mode interference. It is imperative to minimise this using an input filter. Due to parasitic effects of supply lines and components in the input circuit, high frequency oscillations in the MHz range occur during rise and fall of the input current.

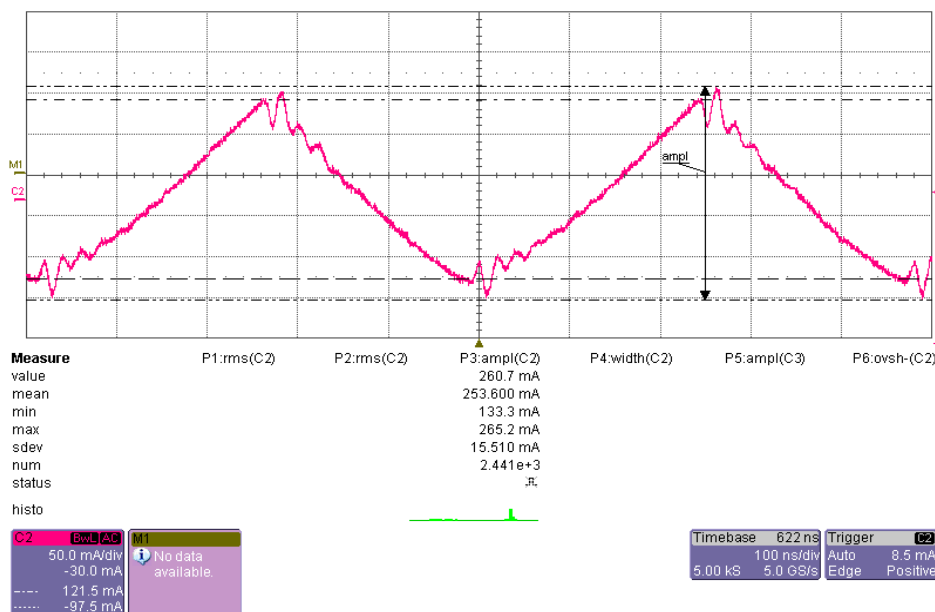

Figure 1: Input current of a DC/DC switching regulator

APPLICATION NOTE



Measurement of the interference voltage on DC/DC switching regulators

The input current, via the ESR of the input capacitor and the impedances of the supply lines of the switching regulator, results in voltage drop, the so-called interference voltage. It must not pass the supply lines of the power supply and must be suppressed to a minimum. The unwanted AC component at the input capacitor of the switching regulator can be determined using measurement with an oscilloscope. This measurement enables a first statement about the interference voltage. Figure 2 shows such a measurement.

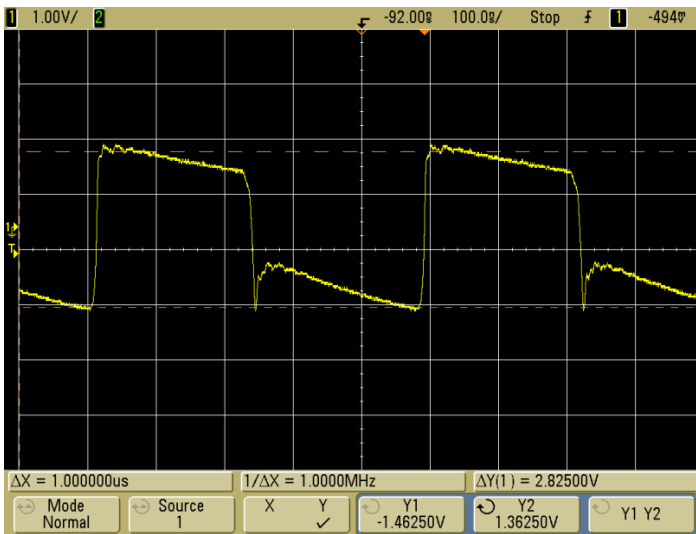

Figure 2: AC component at the input capacitor

In this example, there is an electrolyte capacitor with unknown but relatively high ESR which causes a peak-to-peak value of the unwanted AC component of approx. 2.8 V. Oscillations in the high frequency range caused by parasitic effects are also present. In this example, the frequency of this oscillation is approx. 71 MHz.

APPLICATION NOTE



Measurement of the interference voltage on DC/DC switching regulators

3. Test set-up for the interference voltage measurement

Already accompanying the development, the measurement of the interference voltage of differential mode interference can be performed using an LISN (Line Impedance Stabilisation Network) and a spectrum analyser. The circuit ground forms the reference potential in this test set-up. Figure 3 shows the test set-up.

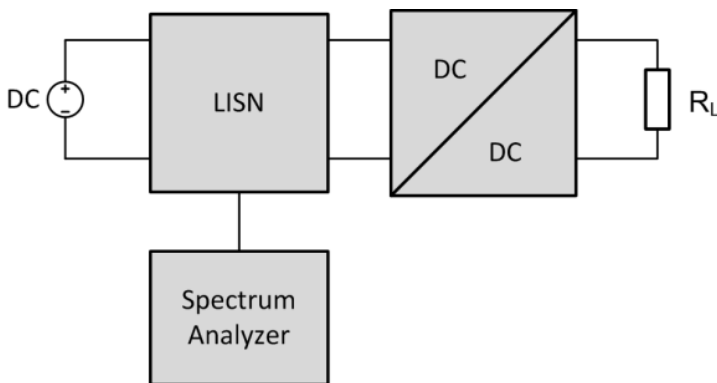

Figure 3: Test set-up for measurement of the interference voltage

This defined test set-up enables performing reproducible measurements and generating defined impedance both for the spectrum analyser as well as for the switching regulator. Figure 4 shows the internal design of a DC-LISN according to CISPR 25.

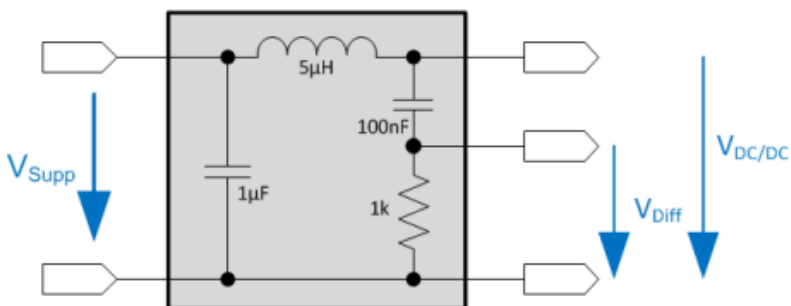

Figure 4: Design of a DC-LISN according to CISPR 25

The CISPR 25 is used as the basis for testing vehicle electrical systems and can be used for EMC testing accompanying development of DC/DC switching regulators. The function of the LISN is decoupling of the interference voltage as pure alternating quantity V_{Diff} . It is measured using the internal 1 k Ω resistance. The internal low pass filter of the LISN prevents interference with other electrical equipment connected to the supply network. The voltage source V_{Supp} is connected to the input terminals of the LISN. The test item, in this case the switching regulator, is connected to the output terminals and also supplied with the voltage $V_{DC/DC}$. Figure 5 shows the result of a peak value measurement of the interference voltage with a spectrum analyser.

APPLICATION NOTE



Measurement of the interference voltage on DC/DC switching regulators

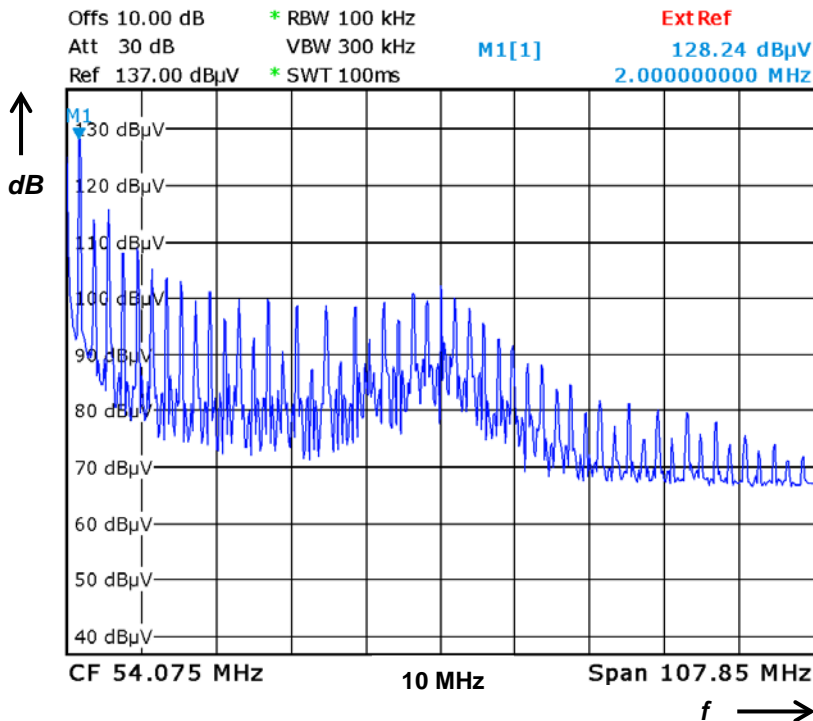

Figure 5: Peak value measurement of the interference voltage under full load

As test item, a DC/DC step-down (buck) converter without input filter was examined with a switching frequency of 2 MHz, input voltage of 10 V and input effective current of 0.7 A. The interference voltage is determined in different frequency ranges depending on the standardisation. In this example, the measurement was performed according to the test regulation CISPR 25 with start frequency of 150 kHz and stop frequency of 108 MHz. The basic oscillation corresponding to the switching frequency is clearly visible. The harmonics reaching into the high MHz range drop in amplitude. The amplitude of the basic oscillation is at its greatest with 128 dBμV. The interference level V_{Diff} is generally defined using the following expression (Equation 1) in dBμV:

$$V_{\text{Diff}} = 20 \log \left(\frac{V_{\text{Ripple}}}{1 \mu\text{V}} \right) \text{ dB}\mu\text{V} \quad (1)$$

If Equation 1 is transformed, the measured interference voltage V_{Ripple} can be approximately determined using Formula 2:

$$V_{\text{Ripple}} = \left(10^{\frac{V_{\text{Diff}}}{20}} \right) * 1 \mu\text{V} = \left(10^{\frac{128}{20}} \right) * 1 \mu\text{V} = 2.6 \text{ V} \quad (2)$$

Using this, we obtain a value for the interference voltage V_{Ripple} of 2.6 V. This approximately corresponds to the peak-to-peak value of the previously measured voltage at the input capacitor (see Figure 2). An input filter is obviously required.

APPLICATION NOTE



Measurement of the interference voltage on DC/DC switching regulators

For example, the CISPR 24 Class 1 defines a limit value of the peak value of 66 dB μ V for narrow band interference and a frequency of 2.0 MHz. However, the limit values according to CISPR 25 and other standards are not applicable for such measurements accompanying the development as the measurement of the differential mode interference is not defined in the EMC standards. However, they can be included to make a rough assessment of the interference emission in power supplies. The worst case is usually considered to be able to determine the maximum interference emission. Therefore, the measurements for switching regulators are performed at full load and smallest input voltage. In order to illustrate this, the same test item, in contrast to the first measurement, was loaded with a load current of only 50 mA. Figure 6 shows this measurement.

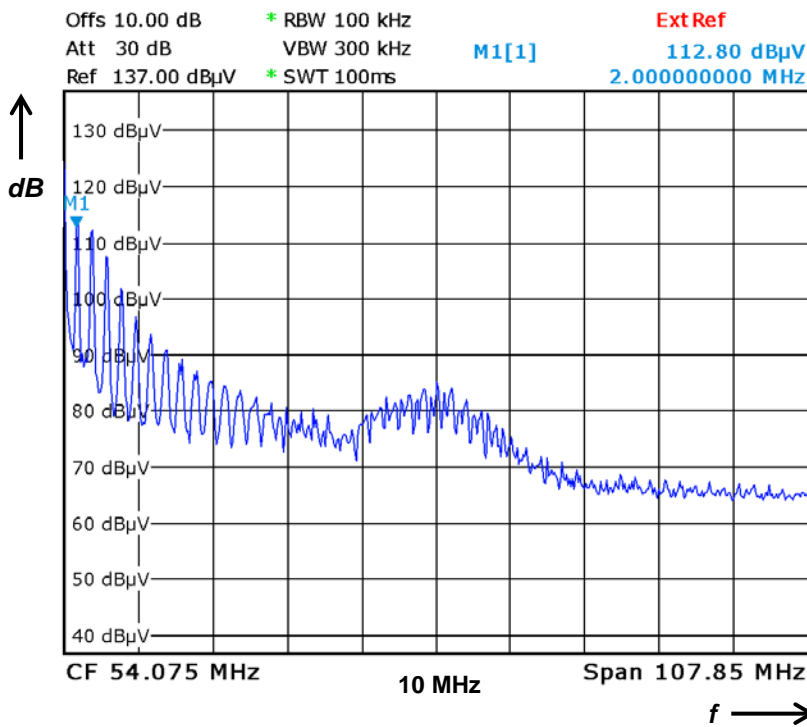

Figure 6: Peak value measurement of the interference voltage at low load

The measurement in Figure 6 shows that the interference emission at low load is lower in the high frequency range. In this case, the basic oscillation shows a value of 112 dB μ V and in comparison with the full load is only 16 dB lower, however not negligible.

APPLICATION NOTE



Measurement of the interference voltage on DC/DC switching regulators

4. Detectors for assessment of the interference voltage

If the test item is tested in an EMC test accredited laboratory, the common mode interferences are measured in relation to ground. According to the standard, then not the peak value, but the quasi and average peak values are measured. These display modes are usually selected for assessment of measurements of the common mode interferences. Many high quality spectrum analysers also have quasi and average peak detectors. Figure 7 shows the simplified block diagram of the input stage of a spectrum analyser.

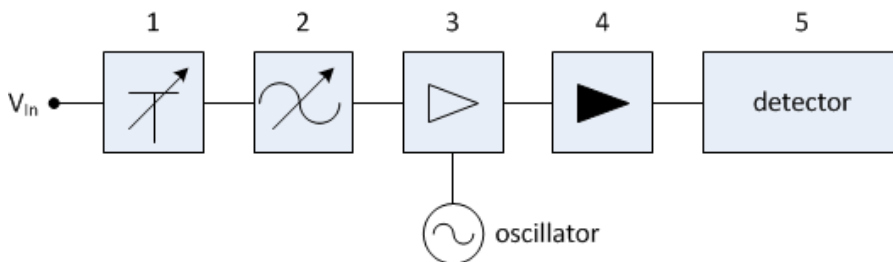

Figure 7: Input stage of the spectrum analyser

The measured interference voltage is conducted via the input attenuator (1) to the band filter (2) and then overlaid in the mixer (3) with an intermediate frequency f_{IF} of an oscillator. The mixed product is amplified in the intermediate frequency amplifier (4) and fed to the detector (5). The display mode to be assessed of the interference voltage is selected at the output of the detector. Figure 8 shows the basic design of an average peak detector.

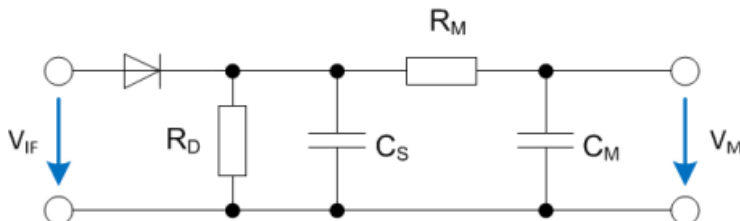

Figure 8: Average Peak Detector

In the average peak detector, the amplified intermediate frequency voltage V_{IF} is first rectified by a diode which charges the storage capacitor C_S to the current value of the envelope curve. The resistor R_D is used for the later discharge of the capacitor C_S . Afterwards, the voltage of the envelope curve is smoothed via the low-pass from R_M and C_M so that finally the arithmetic mean V_M , the average peak, is set at the capacitor C_M . This display mode is selected because modulated carrier frequencies, as occur with switching regulators, can be displayed and assessed using it.

APPLICATION NOTE



Measurement of the interference voltage on DC/DC switching regulators

In the case of the quasi peak detector, similarly to the average peak detector, a storage capacitor C_S is charged. Figure 9 shows the basic design of a quasi peak detector.

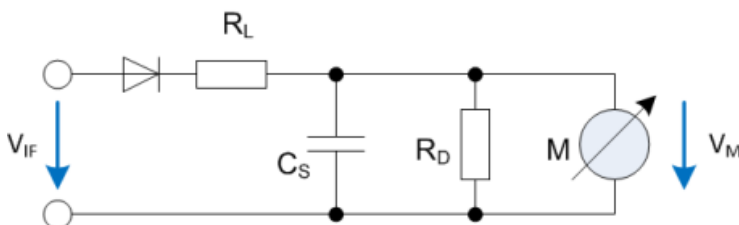

Figure 9: Quasi Peak Detector

The intermediate frequency voltage V_{IF} is first rectified via the diode. Afterwards, the storage capacitor C_S is charged with the time constant $R_L \cdot C_S$ via the load resistor R_L . The storage capacitor C_S can then be discharged using the time constant $R_D \cdot C_S$. The display of the spectrum analyser, here the measuring instrument M , then shows the average value of the charge and discharge pulses of the storage capacitor as quasi peak. In this display mode, the electrical value of the interference voltage is converted to a display which corresponds to the interference impression of the human ear and is received, for example during radio reception as crackle interference.

5. Summary

This Application Note illustrates the necessity of accompanying EMC measurements on switched-mode power supplies during development. An oscilloscope can already make an important statement in advance about EMC interference at the input of the switching regulator. However, measurement of the interference voltage with a spectrum analyser and an LISN are still decisive. If an input filter is already taken into account during the development phase of switching regulators, the filter effect can be checked in the development laboratory using a simple spectrum analyser. Using this method, the developer can determine unwanted interference levels at the switching regulator. With the selective use of filter elements, the developer can ensure that his application passes the final EMC test.

APPLICATION NOTE



Measurement of the interference voltage on DC/DC switching regulators

IMPORTANT NOTICE

Würth Elektronik eiSos GmbH & Co. KG and its subsidiaries and affiliates (WE) assume no liability for application assistance of any kind. Customers may use WE's assistance and product recommendations for their applications and design. The responsibility for the applicability and use of WE Products in a particular customer design is always solely within the authority of the customer. Due to this fact, it is up to the customer to evaluate where appropriate to investigate and decide whether the device with the specific product characteristics described in the product specification is valid and suitable for the respective customer application or not.

Customers are cautioned to verify that data sheets are current. The current data sheets can be downloaded at www.we-online.com. Customers shall strictly observe any product-specific notes, cautions and warnings. WE reserve the right to make corrections, modifications, enhancements, improvements, and other changes to its products and services.

WE does not warrant or represent that any licence, either express or implied, is granted under any patent right, copyright, mask work right, or other intellectual property right relating to any combination, machine or process in which WE products or services are used. Information published by WE regarding third-party products or services does not constitute a licence from WE to use such products or services or a warranty or endorsement thereof.

WE products are not authorised for use in safety-critical applications (such as life support). It has to be clearly pointed out that the possibility of a malfunction of electronic components or failure before the end of the usual lifetime cannot be completely eliminated in the current state of the art, even if the products are operated within the range of the specifications. In certain customer applications requiring a very high level of safety and in which the malfunction or failure of an electronic component could endanger human life or health, customers must ensure that they have all necessary expertise in the safety and regulatory ramifications of their applications, and acknowledge and agree that they are solely responsible for all legal, regulatory and safety-related requirements concerning their products and any use of WE products in such safety-critical applications, notwithstanding any applications-related information or support that may be provided by WE. Further, customers shall fully indemnify WE against any damages arising out of the use of WE products in such safety-critical applications. WE products are neither designed nor intended for use in automotive applications or environments unless the specific WE products are designated by WE as compliant with ISO/TS 16949 requirements. Customers acknowledge and agree that, if they use any non-designated products in automotive applications, WE will not be responsible for any failure to meet such requirements.

USEFUL LINKS

- Application Notes: <http://www.we-online.com/applicationnotes>
Component Selector: <http://www.we-online.com/component-selector>
Toolbox: <http://www.we-online.com/toolbox>
Product Catalogue: <http://katalog.we-online.de/en/pbs/search>

CONTACT INFORMATION

Würth Elektronik eiSos GmbH & Co. KG, Max-Eyth-str. 1, 74638 Waldenburg, Germany

For more information, please visit: <http://www.we-online.com>

Würth Elektronik eiSos GmbH & Co. KG Head Office Waldenburg, Registration Court Stuttgart HRA580801
General Partner Würth Elektronik eiSos Verwaltungs-GmbH, Head Office Waldenburg, Registration Court Stuttgart HRB 581033. Directors Oliver Konz, Thomas Schrott
Bank details UniCredit Bank AG Stuttgart, Account 322 620 136, BLZ 600 202 90, IBAN DE86 6002 0290 0322 6201 36, SWIFT/BIC HYVEDEMM473
VAT No. DE220618976