

Application Note



Single Pair Ethernet for Industrial Applications

ANP085 // FABIAN VORNHAGEN, MARTIN LEIHENSEDER, ROBERT DEMHARTER, ISMAEL MOLINA ALBA, SIMON MARK, JAIRO BUSTOS, MATTHIAS FRITSCHKE

1 Evolution of Ethernet - from 4 pairs to 1 single pair

Starting in the early 1980s as a communication protocol for computer networks, Ethernet and its associated standards has become the most used protocol in industry communication. Copper cables with 2-pairs for Fast Ethernet and 4-pairs cables for Gigabit Ethernet are the core elements in enterprise and industrial networks. With the new Single Pair Ethernet (SPE) technology driven from the car industry, many new use cases are possible to replace analog sensor applications or industrial bus systems.

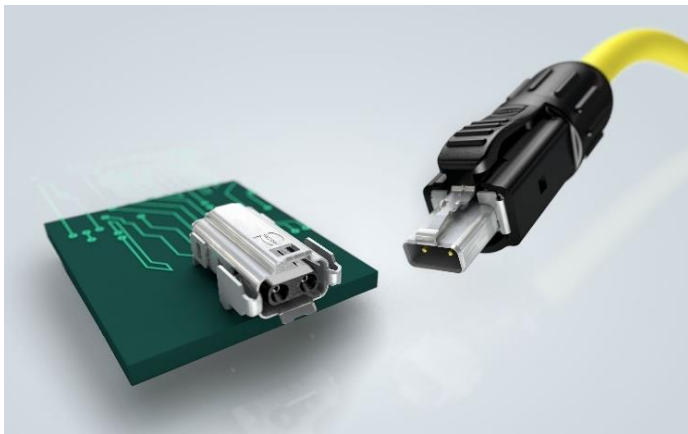

Figure 1: IP20 version of the SPE connector acc. to IEC 63171-6

In 2019 about 59 % of all industrial communication protocols were based on LAN. Still, a high percentage of field bus systems like Profibus or CC-Link (Control and Communication) are in use as well. Many sensors or actuators inside production facilities don't have a requirement for a high data rate. But as the distance between these devices and the field switches often is more than 200 m, Ethernet with a maximum cable length of 100 m comes to its limits.

Besides cable length, the (cable)weight, mechanical connector stability and PCB size reduction were the drivers to create a new standard beyond the RJ45 based multi-pair Ethernet. Single Pair Ethernet (SPE) was developed to fulfil these market requirements and enable borderless IP based communication from the cloud to any sensor or actuator.

This Application Note describes the components needed for Single Pair Ethernet from the cable to the PHY chip. The focus will be set for the right EMI filter design for 10BASE-T1L and 100BASE-T1 and to fulfil communication safety requirements according to IEC 62368-1. This will be demonstrated in a PCB to characterize the effectiveness of the components.

2 SPE -Hardware and components

The new SPE physical layer needs new components like cable connectors, magnetics, semiconductors and other devices. The international standards organisations and the allied companies for SPE have invested a lot of time and money in the last years to make all these parts available. The main standards are already publicly available. Also first components are ready to use and in this way the design of new devices with SPE connectivity is possible.

The SPE electrical requirements are specified in the following IEEE standards:

- IEEE 802.3cg (10BASE-T1) with bandwidth from 0.1 to 20 MHz and reach up to 1000 m.
- IEEE 802.3bw (100BASE-T1) with bandwidth 0.3 to 66 MHz and reach up to 40 m.
- IEEE 802.3bp, (1000BASE-T1) with bandwidth 1 to 600 MHz and reach up to 40 m.

2.1 Cable

Based on the needed transmission speed and link length, two basic types of SPE cables are available and standardized. For 10 Mbit/s networks of up to 1000 m cable length, the following standards specify the cable design:

- IEC 61156-13 - SPE data cable up to 20 MHz bandwidth for fixed installation,
- IEC 61156-14 - SPE data cable up to 20 MHz bandwidth for flexible installation.

For 1 Gbit/s networks up to 40 m these standards are available:

- IEC 61156-11 - SPE data cable up to 600 MHz bandwidth for fixed installation,
- IEC 61156-12 - SPE data cable up to 600 MHz bandwidth for flexible installation.

Compared to traditional Category 5e industrial Ethernet cables with four pairs for 1 GBit/s transmission, there is a significant reduction in space and weight of the cable. Please refer to table 1 for more details.

Dimension	Industrial Ethernet Cat 5e (4x2x24 AWG)	SPE (1x2x22 AWG)	Reduction
Outer diameter	7.8 mm	5.8 mm	26 %
Weight	79 kg/km	42 kg/km	47 %

Table 1: Dimension comparison SPE cable

Application Note

Single Pair Ethernet for Industrial Applications



All these cables are shielded to provide the needed crosstalk resistance for the 40 m 1GBASE-T1 and the 1000 m 10BASE-T1L as demonstrated in figure 2.

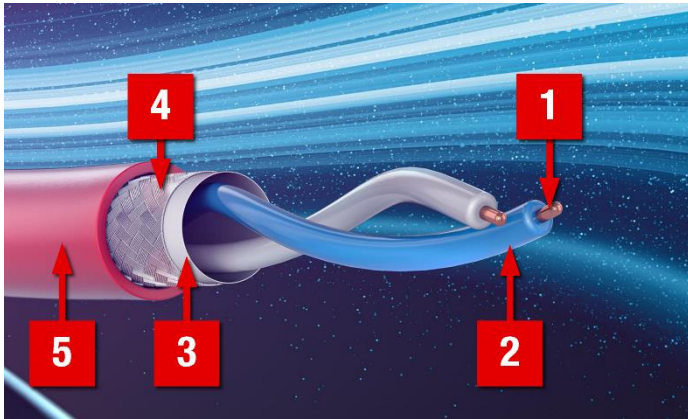

Figure 2: Design for a typical SPE cable (1-copper wire, 2-wire isolation, 3-shielding foil, 4-shielding braid, 5-cable jacket)

Depending on the use case, different cable jacket materials are possible. The copper cross-section of the cable must be selected according to the needed link length and the Power over Data Line (PoDL) requirement. No. 26 AWG and 22 AWG wires are typically taken for link lengths of up to 20 m and 40 m, respectively. For longer link lengths up to 1.000 m, 16 AWG or 18 AWG cables must be used.

To realize the 1 Gbit/s transmission rate over a single pair, the standards define high electrical properties for an SPE cable.

Those include the s-parameters insertion loss (IL), return loss (RL) and alien crosstalk (AXT) over a frequency range up to 600 MHz.

Insertion loss describes the logarithmic ratio between power fed into the cable and the power transmitted through the line. The high demands on IL are necessary to realize the long transmission distances of SPE.

Return loss and the impedance of the cable are important for the reflection behaviour of the overall system. Reflections are interferences on the line. Those interferences could disturb transmitters and receivers. To minimize the reflections, the overall SPE system should have the same characteristic impedance of 100 Ω and low RL values.

For cables with more than one pair, crosstalk describes the signals transmitted between the pairs over inductive and capacitive coupling. This crosstalk disturbs the actual transmission signals on the line. SPE has the advantage that there could be no crosstalk from other pairs, but SPE has to deal with alien crosstalk. ANEXT is crosstalk from other cables in the near environment. To protect the transmission from disturbing ANEXT industrial SPE cables should be well shielded with a combined foil and braid shield.

The foil shield provides a high shielding effectiveness against high frequency electromagnetic fields. The braided shield is used for

mechanical stabilization and shielding of low frequency electromagnetic fields. The effect of a braid depends on the thickness of individual wires and on the degree of coverage. SPE cables for industrial environments should provide a coverage of a minimum 85 %. The braiding of a cable also mainly defines the values for the transfer impedance of a cable shielding.

The shielding effect of a cable works in both directions, which means that the shielding attenuation reduces both the radiation of disturbances of the cable signal as well as disturbances of other devices acting on the cable from outside.

2.2 Connector

For SPE completely new types of connectors are needed. These connectors are smaller compared to the typical RJ45 and offer the same robustness as the often used industrial style M12 D- and X-coded connectors. This new SPE interface is defined in the IEC 63171-6 standard and includes different M8 / M12 versions for very harsh industrial applications and an IP20 interface for in cabinet use cases (see figure 4). All these connector types are based on the same terminal inserts and use a robust pin and socket contact system. This modular design concept with identical terminal inserts in all versions allow the mating of IP20 plugs to IP65 / 67 jacks for testing or set up.

This SPE connector series is specified for 60 V DC / 4 A @ 60°C and fulfills the requirements for all Power over Data Line (PoDL) classes. For harsh industrial environments with a heavy EMC disturbance, the connector has a 360° shielding shell to provide the shielding connection from the cable shielding to the PCB with four shielding pins. These Through Hole Reflow (THR) solder pins also offer a robust connection between the jacks and the PCB (Figure 5).



Figure 4: Different recommended SPE connector acc. to IEC 63171-6

The connector mating face design is symmetrical and the contacts are arranged in parallel with the identical contact length. The RF compliant connector technology allows signal transmissions up to 1000BASE T1..

Application Note

Single Pair Ethernet for Industrial Applications

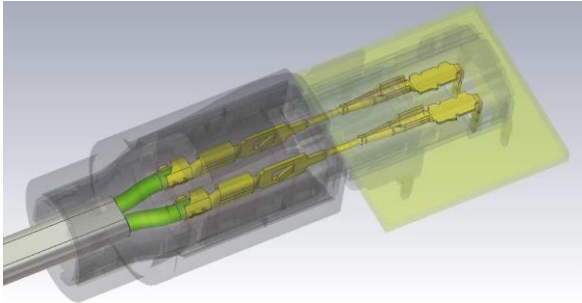

Figure 5: Identical length of the signal paths to avoid runtime differences of the signals

3 Filter Topologies

The MDI (Medium Dependent Interface) forms the connection between cable and the physical medium, the PHY chip, which generates bits from data signals and passes them on for further processing.

The passive components of the MDI have various tasks, such as correct forwarding of data signals, signal interference suppression, electrical isolation or transport of electrical energy up to 60 W in the case of Power over Data Line (PoDL).

To ensure error-free data communication, limits for return loss and mode conversion loss have been defined in various IEEE 802.3 standards.

Figure 6 illustrates the MDI limits for 10BASE-T1 according to IEEE 802.3cg and 100BASE-T1 according to IEEE 802.3bw.

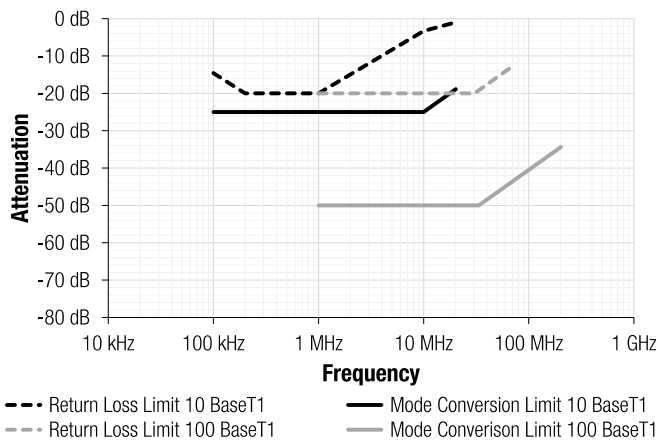

Figure 6: Limits of return loss and mode conversion for the forMDI10BASE-T1 (black) and 100BASE-T1 (grey)

3.1 State of the art

Coming from the automotive sector, there are already finished circuit diagrams for Single Pair Ethernet for 100BASE-T1 with a common mode choke, two capacitors connected in parallel and a termination network for CM interference from the cable.

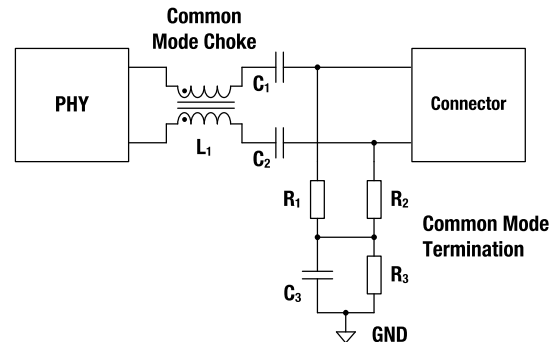

Figure 7: Single Pair Ethernet schematic for automotive Ethernet 100BASE-T1

The common mode choke not only provides filtering of interfering common mode signals, but also helps to improve mode conversion loss and return loss in certain frequency ranges. Due to the lower cut-off frequency at 100BASE-T1 of 1 MHz, the impedance of the choke must be high in low frequencies and, if possible, also cover higher frequencies up to 200 MHz. The number of windings and core size is correspondingly larger.

The matching network to ground (GND) typically consists of three resistors and one capacitor. The two 1 k Ω - resistors (R_1 , R_2 in fig. 7) terminate the pair of wires balanced to ground and thus reduce interfering common mode signals. The 100 nF capacitor (C_3) with the 100 k Ω discharge resistor (R_3) ensures decoupling of direct currents.

The coupling capacitors have capacitances of typically 100 nF and come with 50 V isolation voltage. They are comparatively small and cost-effective, which is why they are used in automotive applications with low-voltage environments and a maximum cable length of 15 m.

3.2 Isolation requirements

Outside the automobile, the IEEE 802.3 standard for signaling systems stipulates the insulation requirement according to IEC 62368-1, which corresponds to 1500 V AC for 60 seconds. A DC voltage of 2250 VDC for 60 seconds or specific test voltage pulses are also permitted. These high insulation voltages cannot be maintained by the 50 V capacitors, so alternative solutions must be sought. The following section therefore describes a solution using a transformer. Detailed measurements and a comparison with capacitors with 2000 V insulation voltage follows in the section Performance Comparison SPE automotive vs. SPE industrial Solutions

At 1 – 66 MHz, the frequency range for SPE 100BASE-T1 is in the Gigabit Multipair Ethernet (1 - 62.5 MHz) range. It is therefore obvious to design a circuit for SPE that is based on the circuit diagram of Gigabit Ethernet, see figure 8.

The central element of the circuit is a signal transformer, which provides the galvanic isolation and ideally does not influence the data signals. The transformer is terminated at its center pins with capacitors to GND. A

Application Note

Single Pair Ethernet for Industrial Applications



common mode choke is used for common mode interference suppression. To ensure protection against ESD pulses, a TVS diode is placed between the common mode choke and the PHY chip. ESD suppression is even better if the TVS diode is located between the connector and the transformer. However, in order not to cause a short circuit between signal pins and GND during hipot tests, the diode must then be disconnected from GND during the test. Figure 8 illustrates the circuit.

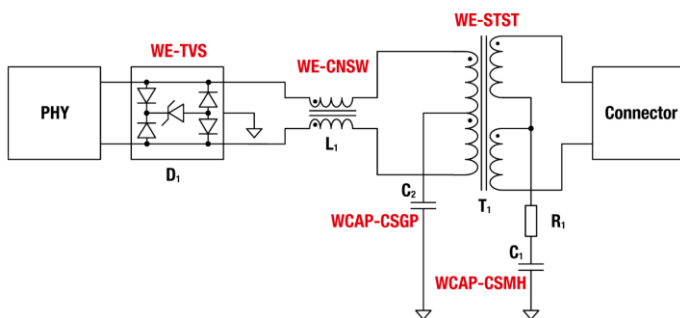

Figure 8: SPE schematic with a transformer solution

The following section describes the individual components of the circuit in more detail.

3.3 Galvanic isolation with a transformer

For SPE a signal transmitter of the WE-STST series is selected. Its compact design compared to conventionally manufactured LAN transformers, together with high inductance of 350 μ H, offers good signal characteristics even at lower frequencies. In addition, it is SMT mountable and is manufactured 100 % automatically.

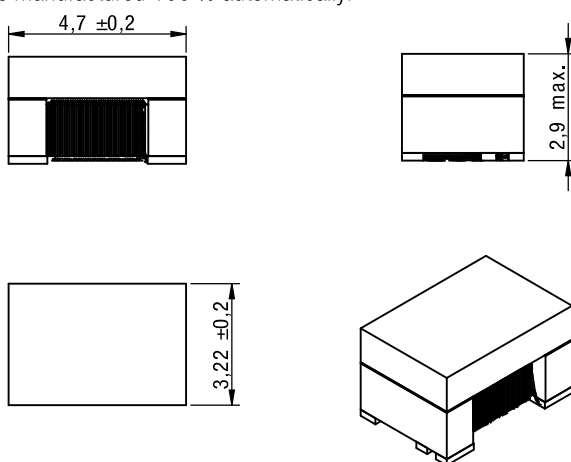

Figure 9: WE-STST shapes and dimensions

The transformer consists of a MnZn core with bifilar windings for both primary and secondary on top of each other for signal coupling. Insulation is provided by an enamel coating of the wires, both on the primary and secondary side. Due to the direct coupling and the transmission ratio of 1:1 differential signals are transmitted with only very low attenuation, DC signals are blocked by the galvanic isolation. Besides the galvanic isolation, a signal transformer needs to transfer data in a determined

frequency range of 1 – 66 MHz for 100BASE-T1 Single Pair Ethernet. For 10BASE-T1 with frequencies between 0.1 and 20 MHz, the same kind of transformer can be used. The parameters for signal integrity are return loss and insertion loss (Sdd21 and Sdd12). Over the complete signal frequency range, the IL should not exceed -3 dB. IL and RL curves for the WE-STST series can be seen in figure 10.

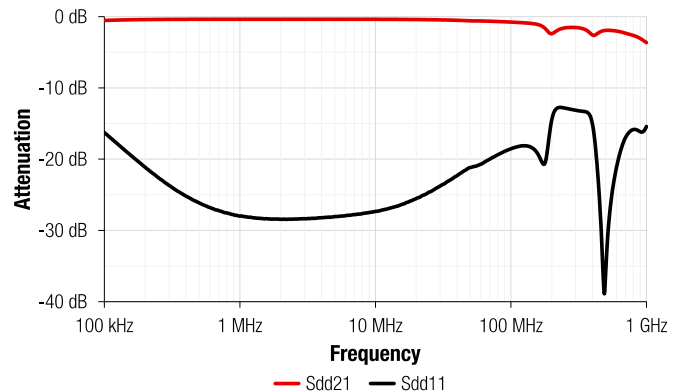

Figure 10: Insertion Loss (red) and Return Loss (black)

More information about the WE-STST can be found here: [SN016a](#)

3.4 Transformer GND termination

The common mode rejection ratio (CMRR) is a parameter that indicates about how well common mode signals are filtered. Although it's not defined in the IEEE 802.3cg or IEEE 802.3bw, it is important to reach good values over the complete frequency range, as common mode signals are the main reason for data failures. The CMRR of the transformer strongly depends on the inter-winding capacitance of the transformer. The CMRR values can significantly be improved by connecting the transformer center tap to ground.

In this way, the center tap GND connection offers an excellent low impedance path for common mode signals (see figure 11).

On the cable side, the GND connection consists of a termination resistor connected to a 1 nF capacitor. The resistor terminates the SPE signal with 100 Ohms while the capacitor provides a low impedance path to GND and has 2 kV galvanic isolation.

Application Note

Single Pair Ethernet for Industrial Applications

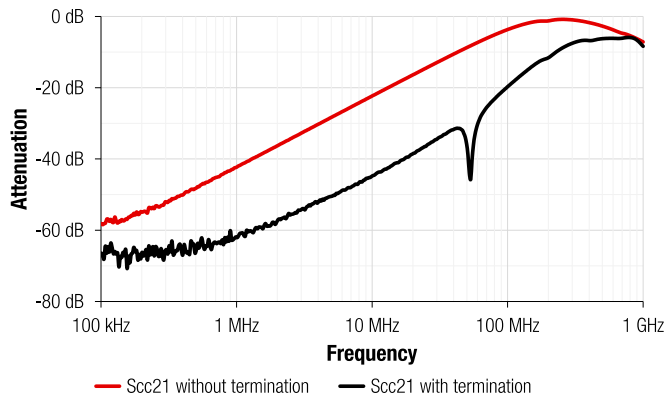

Figure 11: Common Mode Rejection of WE-STST with (black) and without (grey) GND termination

The capacitor C_2 at the center tap of the transformer shown in Figure 8 has two tasks. First, it prevents a short circuit of the PHYs offset voltage to GND. On the other hand, it provides a HF connection to ground, so that common-mode interference is well dissipated. The symmetrization of the signals around 0V is done after the transformer, because it only allows the AC voltage part of the signal to pass through. The DC offset gets blocked. Apart from the center tap pins, the common mode behavior of the transformer also depends on parasitic effects between its windings. By superimposing the windings the leakage inductance will kept as low as possible, however, this increases the parasitic capacity between the windings. The parasitic effects can be reduced to a minimum by selecting the insulation material, the arrangement of the windings and other constructional measures, so that the transformer can be used up to the high frequency range of over 60 MHz.

3.5 Noise suppression with common mode choke

The target of the common mode choke is to balance signal, i.e. to symmetrize the signal in such a way, that no common mode energy is disturbing the information transmitted (the differential mode portion of the signal). To reach this target, the common mode interference should be removed without affecting the integrity of our differential signal. That is why using a common mode choke with large common mode impedance and small differential mode impedance in the desired frequency range is essential.

Based on the graph results and knowing the limits to keep for each of the Ethernet protocols, part number 744232222 for 100BASE-T1 is chosen. It comes in a 1206 package and has an impedance of almost 50Ω at 1 MHz and 2200Ω at 100 MHz.

The choice of the common mode choke also has an influence on the mode conversion. The higher the number of turns in a choke with the same winding technology, the higher (worse for signal integrity) the mode conversion between differential and common mode will be. This implies

that a portion of the differential signal will be converted into common mode in some frequency ranges.

Properties	Test conditions	Value	Tolerance
Z	100 MHz	2200Ω	$\pm 25 \%$
U_R		20 V	Typ.
I_R	$\Delta T = 20 \text{ K}$	200 mA	Max.
R_{DC}	$T = 20 \text{ }^\circ\text{C}$	$1200 \text{ m}\Omega$	Max.

Table 2: Electrical characteristics of the current-compensated choke

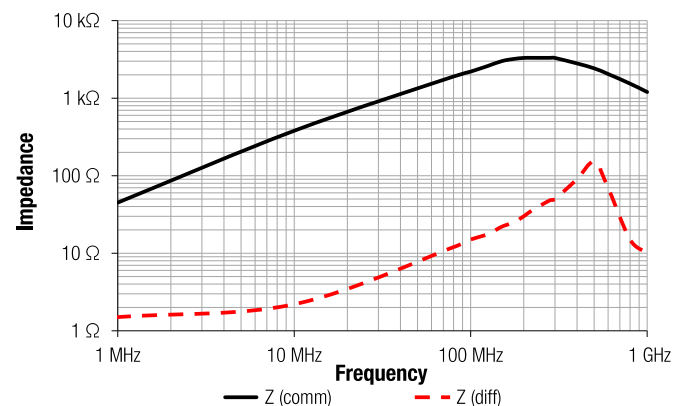

Figure 12: Common mode and differential mode impedance 744232222

3.6 ESD suppression

TVS diodes can clamp overvoltages to a level which is not critical to the ICs and which doesn't tend to couple in other traces. Besides the clamping effect, the TVS diodes shouldn't influence the data signal.

To make sure the SPE data signal will not be disturbed, the parasitic capacitance of the TVS diode should not exceed 2 pF.

For SPE systems article 824012823 is chosen, which can be connected with the two pins for signal input (IO1 and IO2). It comes with a package size of 1.2 mm x 1.0 mm. The diode is suitable for data signals < 3.3 V peak with an input capacitance of 0.27 pF.

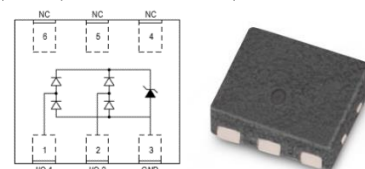

Figure 13: TVS diode schematic and product

At 10 GHz the IL value is +1.57 dB, so the TVS Diode is almost invisible for the data signal.

Figure 14 shows the clamping behaviour during an ESD event. Transmission Line Pulse (TLP) is a test method used to simulate loads that have a short pulse width and rise time. These are similar to those of ESD events. In our case it means to step from 0 A to 13.5 A with 100 ns impulses. For example a 4 kV ESD impulse according to IEC 61000-4-2 generates after 30 ns a current of 8 A. This results to a clamping voltage

Application Note

Single Pair Ethernet for Industrial Applications



of 6 V after the TVS Diode. So the IC just has a voltage of 6 V instead of 4 kV at the signal pin.

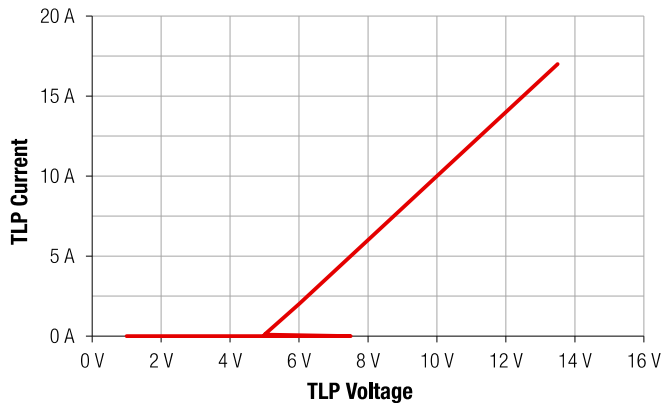

Figure 14: TLP Measurement

In general, the best approach is to place the TVS diode as close as possible to the connector. Because the high frequency ESD Impulse can couple easily to other signal lines. However, during a highpot test the TVS Diode will be triggered into low resistance mode. To avoid short circuits and destruction of the diode by the current flow during hipot tests between signal pins and GND, the diode is either placed between transformer and PHY or (if placed between socket and transformer) separated from GND during the test.

3.7 Performance Comparison SPE automotive vs. SPE industrial

In order to be able to assess the performance of the transformer circuit, it is compared with two other circuits in the following section. The first circuit uses 50 V capacitors with 100 nF for galvanic isolation, which are used in Automotive Ethernet. The second circuit uses 2 kV capacitors with 100 nF. The high demands on the return loss of 10BASE-T1 and the mode conversion loss of 100BASE-T1 lead to different designs of the respective variant. The differences between 10BASE-T1 and 100BASE-T1 designs are mainly the presence or absence of common mode chokes for common mode filtering.

For SPE 10BASE-T1 the circuit diagram with two parallel capacitors, as described in section 3.1, is used.

In the case of 10BASE-T1 the lower signal frequency is 100 kHz, a common mode choke with a low resonant frequency must also be selected. The common mode choke 744272222 not only provides common mode suppression but also has a positive influence on return loss and mode conversion loss. Due to the low cut-off frequency, the dimensions (10 mm x 8.7 mm) and inductance value (2 x 2200 μ H) of the common mode choke are correspondingly large. The common mode rejection for 744272222 is illustrated in figure 15.

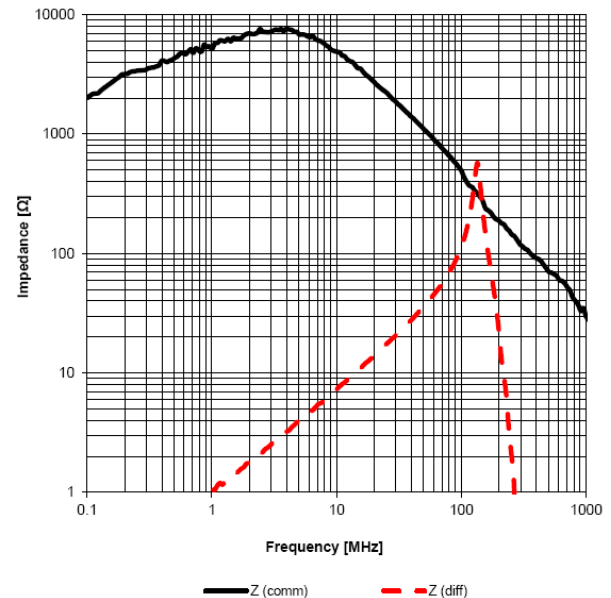

Figure 15: Common mode and differential mode impedance 744272222 for 10BASE-T1

A more compact and electrically equivalent solution is the design with a transformer. Figure 16 shows the transformer design for 10BASE-T1. In contrast to section 4, no common mode choke is required for the 10 Mbit/s design. The reason is the good interference suppression of the transformer at low frequencies. Another difference is the capacitor C_3 on the two center tap pins which extends the transformer bandwidth up to 35 kHz and thus helps to improve the return loss in low frequencies.

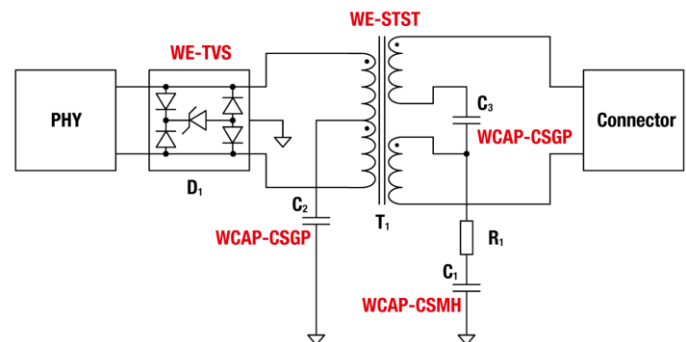

Figure 16: 10BASE-T1 transformer design

Since it is not possible to split the center tap pin on all transformer types, two capacitors can be used on the outer transformer pins as an alternative to C_3 between the transformer center pins, to achieve galvanic isolation. This design enlarges the circuit minimally, but has the advantage, that the similar circuit can be used for Power over Dataline (PoDL) applications. For PoDL the voltage on both capacitors drops only half, thus preventing DC saturation. If only data is transmitted, capacitors with an isolation voltage of 25 V are sufficient, whereas with PoDL an isolation voltage of 100 V is necessary.

Application Note

Single Pair Ethernet for Industrial Applications

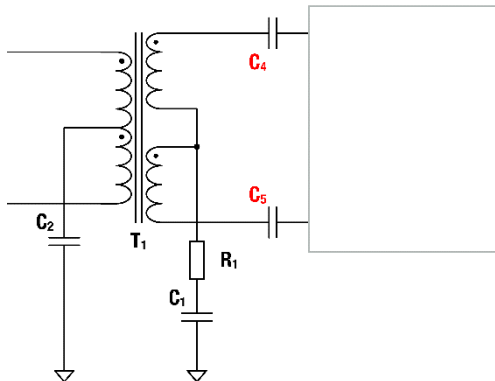

Figure 17: Capacitors C₄ and C₅ on the outer transformer pins as alternative to C₃

In addition to the insulation voltage of the capacitors, their capacitance is important for both circuit diagrams. Simulations and measurements result in a minimum value of 100 nF to meet the limits of IEEE802.3cg. However, the section "146.5.4.2 Transmitter output droop" mentions a maximum voltage drop of 10% between 133.3 ns and 800 ns for a test signal of the PHY chip. To meet this requirement, two changes can be made. Either the inductance of the transformer is increased, which means an increase in size or capacitors with larger capacitance values are used. The second possibility is more space-saving, cheaper and easier to implement. In this case 470 nF capacitors are used to achieve the best compromise between the droop and return loss requirements. As figure 18 and the following equation shows, this circuit design achieves a voltage droop of about 8.3 % and is therefore within the standard.

$$U_{\Delta\%} = \frac{100\%}{V_{133\text{ns}}} \cdot (U_{133\text{ns}} - U_{800\text{ns}})$$

$$U_{\Delta\%} = \frac{100\%}{602.5\text{ mV}} \cdot (602.5\text{ mV} - 552\text{ mV}) = 8.3\%$$

Figure 19 illustrates the differences in size of the different circuits. The common mode choke takes up the most space on the PCB of the two 10 MBit designs with capacitor. Relatively large are also the 2 kV capacitors with 100 nF.

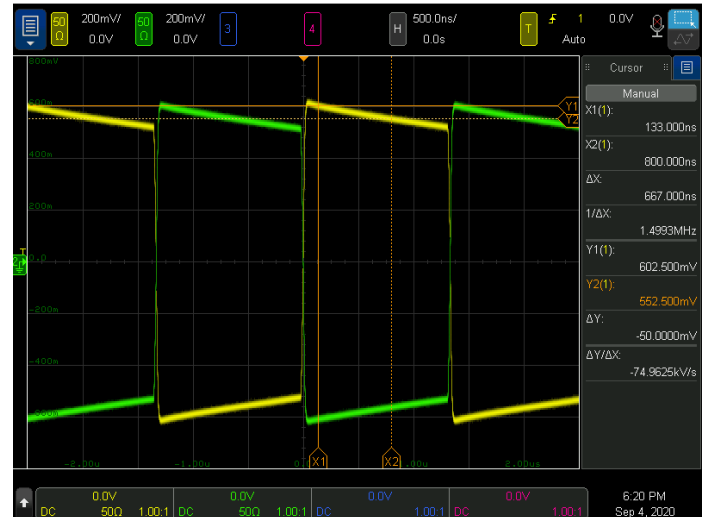

Figure 18: Measurement on the oscilloscope: The voltage drop on the signal plateau represents the voltage drop

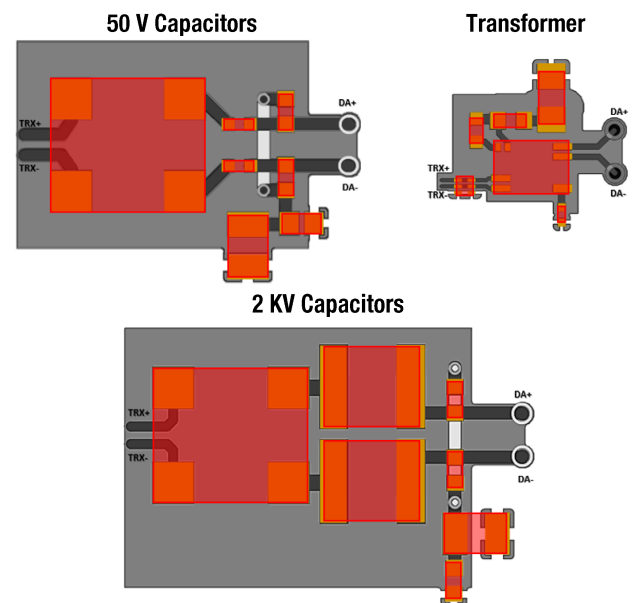

Figure 19: Footprint with different filter designs. 1. SPE 50 V isolation capacitors; 2. 1500 V isolation transformer without CMC; 3. 2000 V isolation capacitors

3.8 Measurement

As the RL measurement shows, the values which represent the capacitor solutions (in figure 20 grey and black) are almost exactly one above the other. The RL readings for both cap solutions come very close to the IEEE limit line between 100 kHz and 200 kHz. Significantly better values are achieved by the transformer design (red curve), which also achieves better results than the capacitor solution at higher frequencies from 5 MHz.

Application Note



Single Pair Ethernet for Industrial Applications

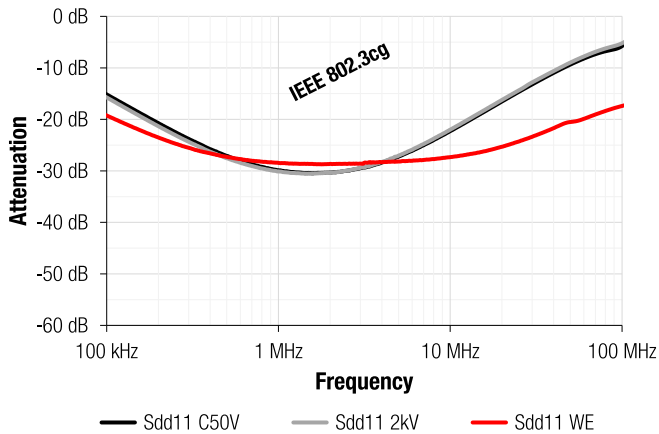

Figure 20: 10BASE-T1 return loss measurement with 50 V capacitors (grey); 2000 V capacitors (black) and transformers (red)

All three measurements show very good values for the mode conversion loss. This can be seen from the fact that the distance between target and actual values is always between 30 and 40 dB. The capacitor solutions are still somewhat better between 0.1 and 6 MHz and the transformer solution between 6 and 20 MHz.

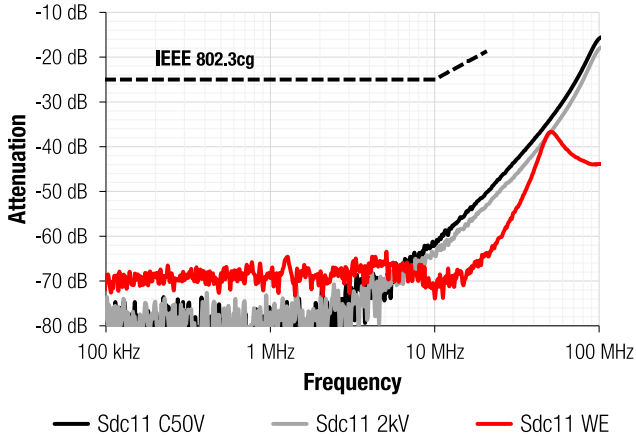

Figure 21: 10BASE-T1 mode conversion loss measurement

3.9 100BASE-T1

The 50 V capacitor design corresponds to the circuit diagram in section 3.1. The common mode choke can be dimensioned much smaller compared to the 10BASE-T1 design, because interference suppression in low frequencies between 0.1 and 1 MHz is not necessary. Due to the size reduction of the Common Mode Choke, the 50 V solution is the most compact of all three designs.

Although significantly smaller due to the smaller choke, the footprint of the 2 kV capacitor design remains the largest of all designs in terms of area (see figure 22). Apart from the large capacitors, there are no differences to the 50 V automotive Ethernet design.

Unlike 10BASE-T1, the transformer design requires a common mode choke for interference suppression in frequencies up to 200 MHz. The circuit diagram corresponds to that in section 4, "Solutions". The common mode choke suppresses both mode conversion and common mode signals in the higher frequencies.

The results are described in more detail in the next section "Measurement".

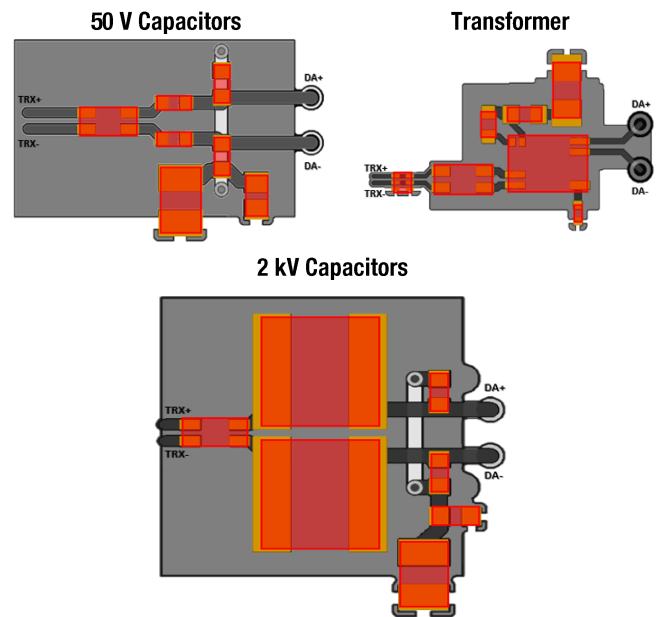

Figure 22: Size comparison of different footprints on the PCB for Single Pair Ethernet 100BASE-T1

3.10 Measurement

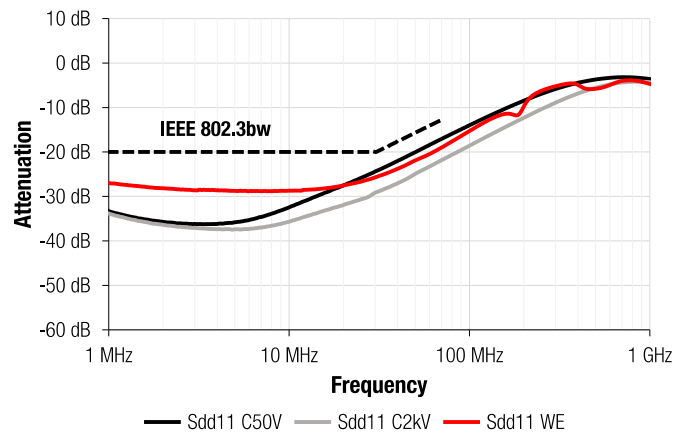

Figure 23: 100BASE-T1 Return Loss measurement

In the return loss measurement, the values in the frequencies between 1 - 20 MHz are closer to the nominal curve in the transformer solution than in the other two designs, with the 2 kV capacitor solution still showing the best results. Overall, the values of all traces are at a sufficient distance from the return loss limit (at least 3 dB).

Application Note



Single Pair Ethernet for Industrial Applications

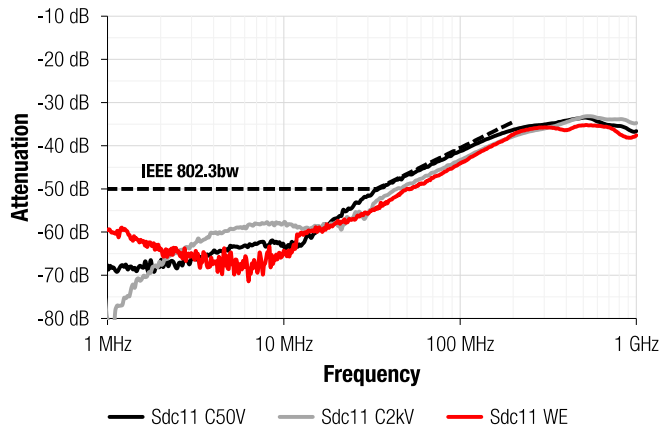

Figure 24: 100BASE-T1 mode conversion loss measurement

In the case of mode conversion loss, the measured values in the design with the 50 V capacitors from 25 MHz are very close to the limit of the IEEE standard and in some cases almost exceed it. The transformer design and that of the 2 kV capacitors prove to be a better alternative here. In this frequency range, their measurement curves have a significantly greater distance from the nominal curve (about 3 dB).

4 Summary / Conclusion

With both capacitor solutions, the expected component tolerances mean that it cannot be guaranteed that the return loss of the circuit will meet the requirements of IEEE 802.3cz for 10BASE-T1. In addition, the footprint is large compared to the transformer due to the common mode choke and, in the case of the 2 kV cap solution even larger.

For the 100BASE-T1 designs, the 50 V cap solution proves to be only partially suitable to meet the mode conversion loss requirement at frequencies > 30 MHz. Even if the fact of the mandatory electrical isolation according to IEC 62368-1 is disregarded, the transformer solution is the most compact and, in terms of signal stability, the most suitable solution for Single Pair Ethernet, both 10BASE-T1 and 100BASE-T1.

Application Note



Single Pair Ethernet for Industrial Applications

A. Appendix

A.1. BOM

Description	Package	Electrical Specification	Manufacturer	Order Code
SPE cable IP20		4 A / 60 VDC / 600 MHz	Harting	33280101001
SPE jack		4 A / 60 VDC / 600 MHz	Harting	09452812800
TVS Diode	DFN1210	3,3 V _{DC} ; 0,18 pF	Würth Elektronik	824012823
Common Mode Choke	1206	Z = 2200 Ω @ 100 MHz	Würth Elektronik	744232222
Signal Transformer	1812	2250 V(DC); 350 μH	Würth Elektronik	74930000
Capacitor 1	1206	1 nF, 2000 V _{DC}	Würth Elektronik	885342208024
Capacitor 2	0402	100 nF ; 50 V _{DC}	Würth Elektronik	885012205086
Capacitor 3	0603	470 nF ; 25 V _{DC}	Würth Elektronik	885012206075
Resistor	0603	100 Ω		---

Application Note



Single Pair Ethernet for Industrial Applications

IMPORTANT NOTICE

The Application Note is based on our knowledge and experience of typical requirements concerning these areas. It serves as general guidance and should not be construed as a commitment for the suitability for customer applications by Würth Elektronik eiSos GmbH & Co. KG. The information in the Application Note is subject to change without notice. This document and parts thereof must not be reproduced or copied without written permission, and contents thereof must not be imparted to a third party nor be used for any unauthorized purpose.

Würth Elektronik eiSos GmbH & Co. KG and its subsidiaries and affiliates (WE) are not liable for application assistance of any kind. Customers may use WE's assistance and product recommendations for their applications and design. The responsibility for the applicability and use of WE Products in a particular customer design is always solely within the authority of the customer. Due to this fact it is up to the customer to evaluate and investigate, where appropriate, and decide whether the device with the specific product characteristics described in the product specification is valid and suitable for the respective customer application or not.

The technical specifications are stated in the current data sheet of the products. Therefore the customers shall use the data sheets and are cautioned to verify that data sheets are current. The current data sheets can be downloaded at www.we-online.com. Customers shall strictly observe any product-specific notes, cautions and warnings. WE reserves the right to make corrections, modifications, enhancements, improvements, and other changes to its products and services.

WE DOES NOT WARRANT OR REPRESENT THAT ANY LICENSE, EITHER EXPRESS OR IMPLIED, IS GRANTED UNDER ANY PATENT RIGHT,

COPYRIGHT, MASK WORK RIGHT, OR OTHER INTELLECTUAL PROPERTY RIGHT RELATING TO ANY COMBINATION, MACHINE, OR PROCESS IN WHICH WE PRODUCTS OR SERVICES ARE USED. INFORMATION PUBLISHED BY WE REGARDING THIRD-PARTY PRODUCTS OR SERVICES DOES NOT CONSTITUTE A LICENSE FROM WE TO USE SUCH PRODUCTS OR SERVICES OR A WARRANTY OR ENDORSEMENT THEREOF.

WE products are not authorized for use in safety-critical applications, or where a failure of the product is reasonably expected to cause severe personal injury or death. Moreover, WE products are neither designed nor intended for use in areas such as military, aerospace, aviation, nuclear control, submarine, transportation (automotive control, train control, ship control), transportation signal, disaster prevention, medical, public information network etc. Customers shall inform WE about the intent of such usage before design-in stage. In certain customer applications requiring a very high level of safety and in which the malfunction or failure of an electronic component could endanger human life or health, customers must ensure that they have all necessary expertise in the safety and regulatory ramifications of their applications. Customers acknowledge and agree that they are solely responsible for all legal, regulatory and safety-related requirements concerning their products and any use of WE products in such safety-critical applications, notwithstanding any applications-related information or support that may be provided by WE.

CUSTOMERS SHALL INDEMNIFY WE AGAINST ANY DAMAGES ARISING OUT OF THE USE OF WE PRODUCTS IN SUCH SAFETY-CRITICAL APPLICATIONS.

USEFUL LINKS



Application Notes

www.we-online.com/appnotes



REDEXPERT Design Plattform

www.we-online.com/redexpert



Toolbox

www.we-online.com/toolbox



Produkt Catalog

www.we-online.com/products

CONTACT INFORMATION

appnotes@we-online.com

Tel. +49 7942 945 - 0



Würth Elektronik eiSos GmbH & Co. KG
Max-Eyth-Str. 1 · 74638 Waldenburg · Germany

www.we-online.com

